

INTRODUCTION TO COOPER

COOPER SPLIT ROLLER BEARINGS



COOPER
SPLIT ROLLER BEARINGS

INTRODUCTION

Cooper designs, manufactures and supplies cylindrical split roller bearings. The company operates globally and has pioneered the development and manufacturing of top-quality split bearings for over 100 years.

Cooper invented the split-to-the-shaft system and, in continuing to develop it, has grown to be a recognised world leader with vast experience and expertise in the area of split bearings.

With worldwide representation and unbeatable know-how, Cooper is a full-service provider, offering the whole palette of services from bearing selection through installation and training to maintenance, repair and other technical support.

All products are manufactured in England. The reliability of Cooper products and business processes is underlined by its ISO 9001 and 14000 accreditation as well as registration with Lloyds and BSI.

The distinct benefits a Cooper bearing brings to machinery are:

- Superior sealing
- Easy and quick assembly in-situ
- Cost savings and higher productivity
- Extended L10 life
- Easy and friendly maintenance
- Freeing up design
- Energy efficiency
- Pre-set clearances

An alternative worth choosing from the beginning

Cooper split roller bearings offer an alternative to conventional double row spherical bearings, as well as white metal bush and other bearing types. They can replace the majority of spherical or bush bearings in rotational equipment in plummer blocks or similar housings. However, the greatest long-term benefits can be gained by specifying original Cooper split bearings from the design stage. This guarantees smooth, trouble-free running throughout the life cycle of the machinery, and customers can achieve tremendous cost-savings, with rapid return on investment.

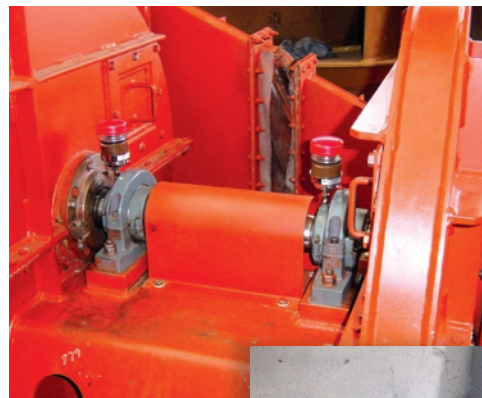
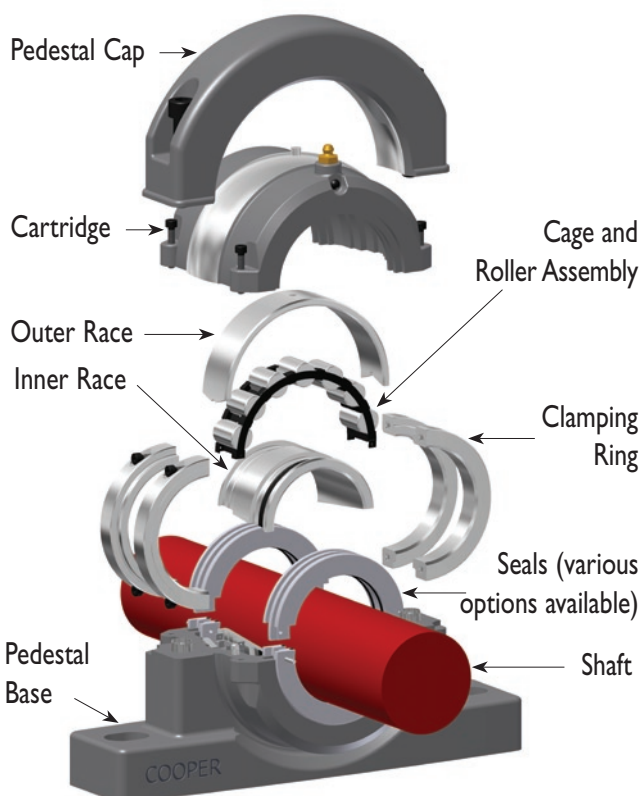

Cooper bearing in a trapped position on a fan



Cooper bearing on a covered conveyor

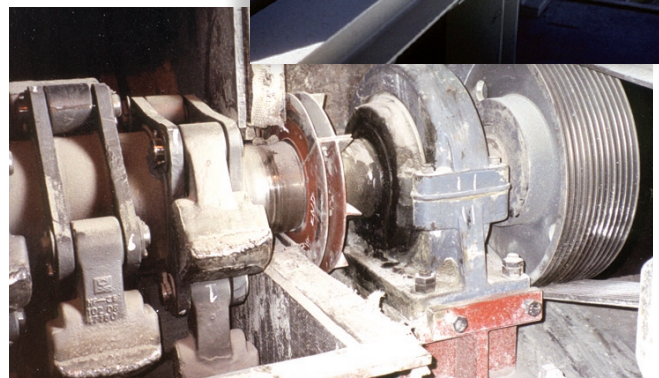

Cooper bearing in a trapped position on a clinker breaker drive

Applications and Industries where Cooper bearings are a favourite solution

Over the years Cooper split roller bearings have been used in many different types of machinery, much of it heavy duty, including FANS, CONVEYORS, CRUSHERS and BREAKERS, SCREENS, CONTINUOUS CASTERS, COOLING BEDS, ROTARY DRUMS, PRESSES, PUMPS, PROPULSION SYSTEMS, MOTORS and ELEVATORS. Equipment served by Cooper bearings can be found in highly demanding industries such as STEEL, POWER GENERATION, MINING, CEMENT, ALUMINIUM, CHEMICAL (e.g. FERTILIZER), MARINE, SUGAR and WATER TREATMENT. These bearings have proven to be indispensable products, the ideal solution where downtime is a major issue and total reliability a must.



A well-known power plant benefits from the total reliability of the Cooper bearings installed on its fans.



Sugar cane processing equipment with Cooper bearings in trapped positions.

A premier cement plant chose to use Cooper on all conveyors to optimise productivity and reduce maintenance work



A leading steel manufacturer uses continuous casters with Cooper bearings specified from the start.

Cooper Split Roller Bearing

Seal remains parallel to the shaft

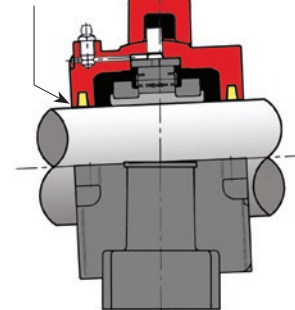

Double Row Spherical Bearing

Gap between seal and shaft

Seal binds

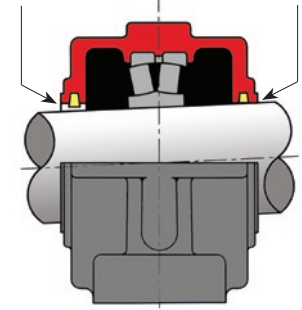

Handling misalignment - comparison

'Problem' locations are a problem no longer!

Cooper bearings operate particularly well in trapped locations, harsh environments, extreme conditions and on critical path equipment. This is because they display considerably better performance with respect to life, load, sealing and serviceability. The swivel cartridge accommodates angular misalignment and the constantly concentric sealing promotes longer life. And all the components incorporate the split-to-the-shaft technology so, when dismantling or servicing the bearings, there is no need to remove or disturb adjacent machinery. As a result, Cooper bearings are often used in special situations such as underground or overhead locations or on recessed shafts, while the unique superior sealing feature allows them to outperform competitors' bearings even in shaft-end positions.

The little things that make a big difference

Cooper bearings have performed well in applications where conventional systems failed. Often, these failed bearings might have given satisfactory performance under 'normal' conditions. However, in the case of a conveyor head or a tail of shaft, for example, conditions are far from 'normal', and rigid sealing solutions just cannot handle the combination of shaft misalignment and a dirty operating environment.

Sometimes auxiliary equipment, such as forced oil circulating systems and associated control systems, demands a high degree of maintenance, resulting in unacceptable downtime. The Cooper split roller bearing needs only grease lubrication and, in most applications, eliminates this problem.

Furthermore, a fundamental advantage of the 'split' solution is that there is full accessibility and no need to dismantle associated components. This makes it ideal for any equipment which



OEMs often specify Cooper bearings for their heavy-duty machinery.

constitutes a potential bottleneck and would otherwise need frequent and extensive shutdown periods. Whether due to breakdown or to scheduled service activity, reducing downtime will inevitably reduce or even eliminate income losses and increase efficiency.

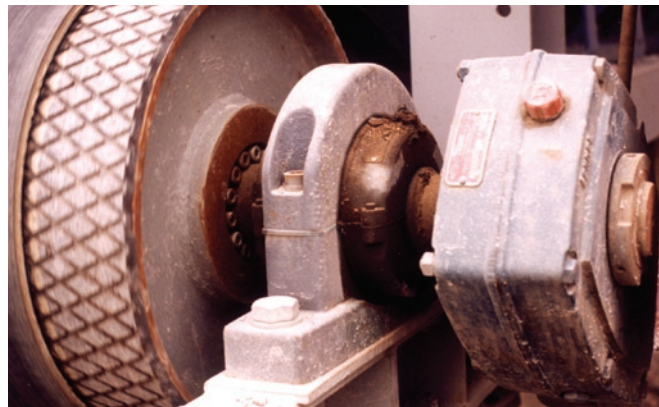

Cooper bearing on a conveyor in a trapped position

When selecting bearings, it is important to focus on the true life-cycle cost rather than the immediate cost. Over the longer term, Cooper roller bearings offer a far more cost-effective and reliable solution, particularly when the implications, and risks, of premature failure are included in the calculation. Making Cooper your first choice offers immediate benefits and can save you a world of trouble.

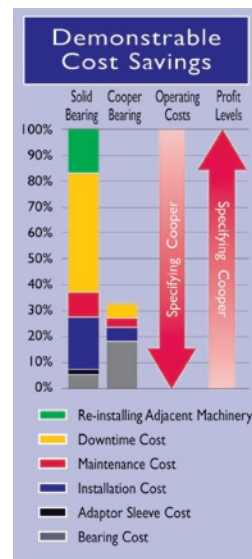

COOPER BEARINGS GROUP

UK, Europe, South America, Asia, Australia and the Middle East

Cooper Roller Bearings Company Ltd.

Wisbech Road

Kings Lynn, Norfolk, PE30 5JX

United Kingdom

Tel: +44 (0) 1553 763447

Fax: +44 (0) 1553 761113

Email: CoopersalesUK@kaydon.com

USA, Canada, Mexico and Central America

The Cooper Split Roller Bearing Corp.

5365 Robin Hood Road, Suite B

Norfolk, VA 23513

USA.

Tel: +1 (1) 757 460 0925

Fax: +1 (1) 757 464 3067

Email: CoopersalesUS@kaydon.com

Germany

Cooper Geteilte Rollenlager GmbH.

Postfach 100 423

Oberbenrader Str. 407

47704 Krefeld GERMANY

Tel: +49 (0) 2151 713 016

Fax: +49 (0) 2151 713 010

Email: CoopersalesDE@kaydon.com

People's Republic of China

Cooper Bearings Group Beijing.

Room 909, Canway Building Tower I

No 66, Nanlishi Road, Xicheng District,

Beijing

PRC 100045

Tel: +86 (0) 10 68080803

+86 (0) 10 68080805

+86 (0) 10 68080806

Fax: +86 (0) 10 68080801

Email: CoopersalesCN@kaydon.com

Hong Kong

Cooper Roller Bearings (Hong Kong) Co. Ltd.

21st Floor Chinachem Tower

34-37 Connaught Road Central, Hong Kong

Tel: +852 6050 6633

Tel: +86 (0) 135 7010 7075

Email: CoopersalesHK@kaydon.com

Brazil

Cooper do Brasil Ltda.

Caixa Postal 66.105

CEP 05.314-970, Brasil

Tel: +55 (0) 11 3022 3706

Tel: +55 (0) 11 9156 2500

Email: CoopersalesBR@kaydon.com

India

Cooper Roller Bearings Company Ltd.

Wisbech Road

Kings Lynn, Norfolk, PE30 5JX

United Kingdom

Tel: +91 (0) 9820180089

Email: CoopersalesIN@kaydon.com