

COOPER BEARINGS GROUP

UK, Europe, South America, Asia, Australia and the Middle East

Cooper Roller Bearings Company Ltd.
Wisbech Road
Kings Lynn
Norfolk
PE30 5JX
United Kingdom

Tel: +44 (0) 1553 763447

Fax: +44 (0) 1553 761113

Email: CoopersalesUK@kaydon.com

USA, Canada, Mexico and Central America

The Cooper Split Roller Bearing Corp.
5365 Robin Hood Road
Suite B
Norfolk
VA 23513
USA.

Tel: +1 (1) 757 460 0925

Fax: +1 (1) 757 464 3067

Email: CoopersalesUS@kaydon.com

Germany

Cooper Geteilte Rollenlager GmbH.
Postfach 100 423
Oberbenrader Str. 407
47704 Krefeld
GERMANY

Tel: +49 (0) 2151 713 016

Fax: +49 (0) 2151 713 010

Email: CoopersalesDE@kaydon.com

People's Republic of China

Cooper Bearings Group Beijing.
Room 909, Canway Building Tower 1
No 66, Nanlishi Road
Xicheng District
Beijing
PRC 100045

Tel: +86 (0) 10 68080803

+86 (0) 10 68080805

+86 (0) 10 68080806

Fax: +86 (0) 10 68080801

Email: CoopersalesCN@kaydon.com

Hong Kong

Cooper Roller Bearings (Hong Kong) Co. Ltd.
21st Floor Chinachem Tower
34-37 Connaught Road Central,
Hong Kong

Tel: +852 6050 6633

Tel: +86 (0) 135 7010 7075

Email: CoopersalesHK@kaydon.com

Brazil

Cooper do Brasil Ltda.
Caixa Postal 66.105
CEP 05.314-970
Brasil

Tel: +55 (0) 11 3022 3706

Tel: +55 (0) 11 9156 2500

Email: CoopersalesBR@kaydon.com

India

Cooper Roller Bearings Company Ltd.
Wisbech Road
Kings Lynn
Norfolk
PE30 5JX
United Kingdom

Tel: +91 (0) 9820180089

Email: CoopersalesIN@kaydon.com

PRODUCT CATALOGUE

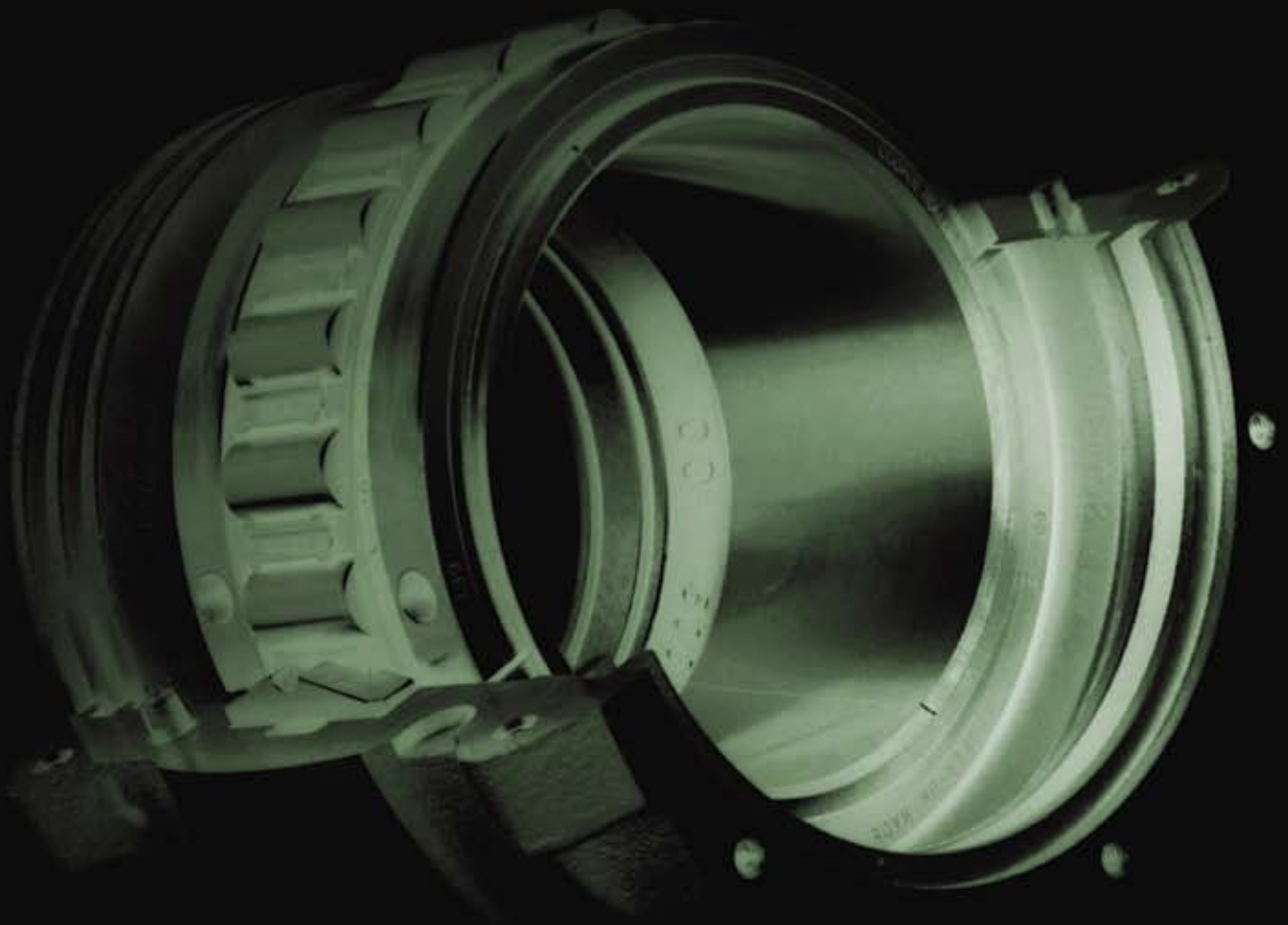

COOPER
SPLIT ROLLER BEARINGS

INTRODUCTION

As a company that has been established for over 100 years, Cooper Bearings Group has an international presence, with sales offices in the UK, USA, China, India and Germany. With unrivalled experience and expertise within our field, across the globe, we know we offer the best solution.

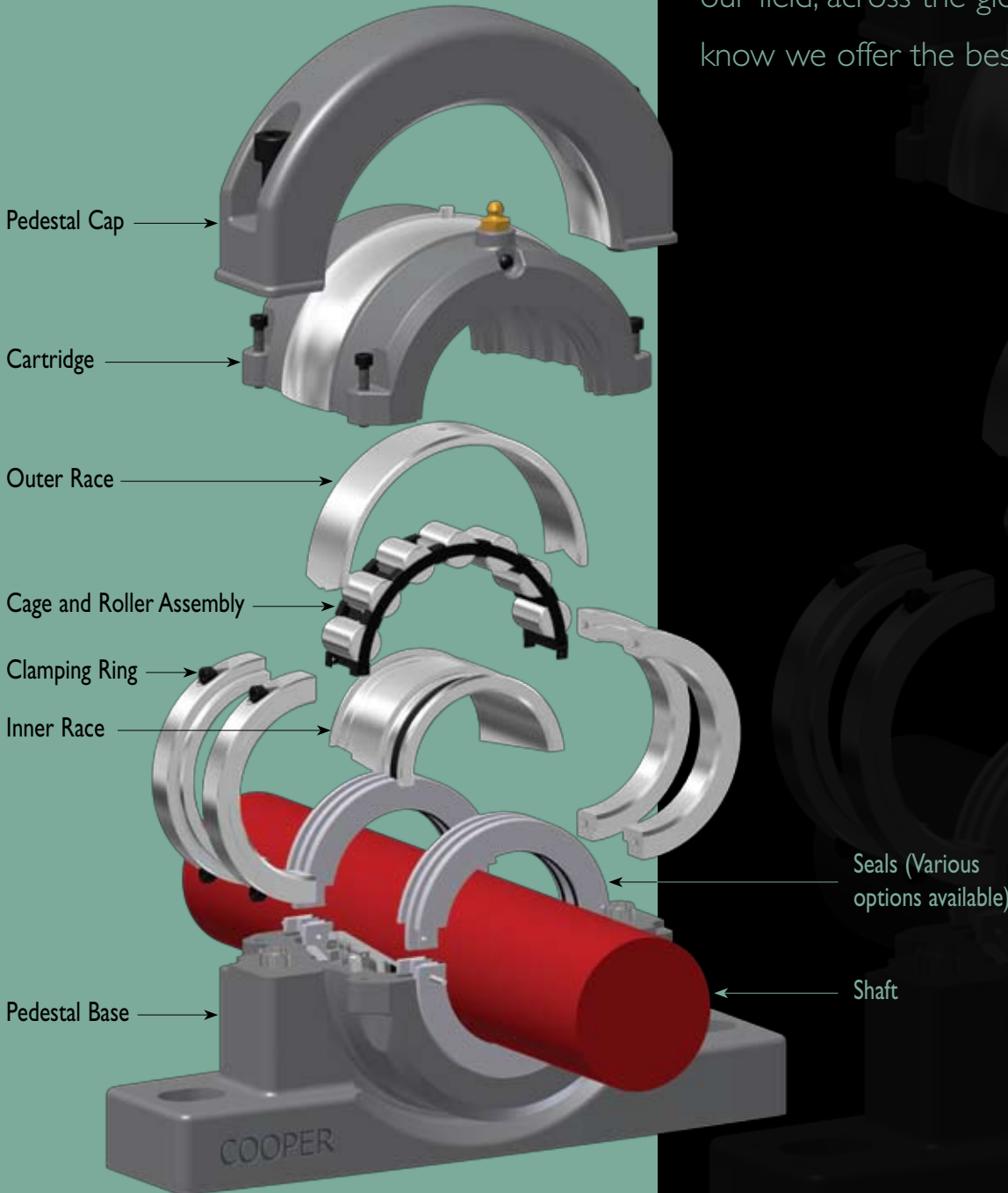

What is the solution?

We provide split to the shaft roller bearings with a range of additions, which can be tailored to suit your specific application. And, if we don't already make it, then we can work with you to produce a bespoke split roller bearing to solve your particular problem.

Why should you care?

The Cooper Bearings Group is always striving for continuous innovation, spurred by competition and the desire to provide you and your customers with constant productivity improvements and high value.

We serve three key markets with our specialist, environmentally sustainable, value adding products: OEMs, industrial end-users and distribution partners.

With competition growing within your industry and margins being continually squeezed, we understand that for you and your customers achieving performance gains and running existing equipment to its full potential is increasingly important to stay ahead. We know that you or your customers can't afford large amounts of machinery downtime, whether it's at scheduled maintenance times or through failures.

There is one proven answer to reducing production loss and overall machinery overheads. That is the use of split roller bearings.

Is a split really the answer?

Are you looking for a bearing solution that doesn't need to be changed regularly?

In comparison to a solid bearing, split roller bearings are often better adapted to the environment they are required to work in. Therefore they need to be changed far less.

Are you looking for a bearing solution that is easy to assemble and install?

In comparison to a solid bearing, where trapped locations are involved, split roller bearings are easier to fit. Ancillary equipment and clutter on the shaft, either side of a bearing, does not need to be removed for bearing replacement to take place.

If you want to reduce the amount of time and effort required when fitting a bearing, and to reduce or eliminate the need for heavy lifting equipment to remove adjacent machinery, all you need is a split roller bearing.

And how many times do you hear 'easy to install' and then are faced with a complex puzzle before you?

Well, Cooper really is easy to install. With pre-set clearances and no specialist fitting tools required, even in trapped positions, it's simple.

Finally, do you want a solution that isn't going to cost a fortune?

With its unique attributes, a split roller bearing reduces production downtime and in many cases reduces the amount of changes required, as well as reducing power consumption. So if you're tasked with increasing efficiency, it's job done with a split roller bearing!

In the long run, Cooper offer a far more profitable solution compared to a solid. As well as this we provide an opportunity to reduce the initial cost of machines. With far greater flexibility in design afforded by use of split roller bearings, shafts and other adjacent components can often be simplified without compromising on performance.

Service second to none

Do you have a bearing that needs a little bit of attention? Perhaps your bearing still has plenty of life left in it and serves its purpose, but there are just a few things that could be improved? Maybe elements of it have been worn down by every day wear and tear, but on the whole its fine? Or maybe you've had a few changes in operation, so it's not performing to its best?

Whatever the problem, Cooper can help. We can refurbish an existing bearing to ensure you get the best out of it. And the good news is your bearing doesn't even need to be a Cooper. With a highly skilled workforce, with unparalleled experience and expertise in a broad range of applications and operating conditions, we can refurbish a broad range of split and 'solid' bearings.

And it doesn't stop there; if you have purchased a split roller bearing, whether through Cooper or someone else, and require assistance with installation then look no further. Whatever the size or specification, we have a team of qualified engineers on hand to fit split roller bearings any time. Not only that, but we can maintain your bearings once installed, ensuring they always run at an optimum performance level.

Bearing types	Pages 4-7
Bearing mounting options	Page 8
Comparison of series	Page 9
Joint gaps and internal clearances	Page 10
Bearing selection	Pages 11-13
Shaft tolerance and journal dimensions	Pages 14-15
Vibration data	Pages 16-18
Sealing solutions	Pages 19-21
Blanking plates	Pages 22-23
Lubrication	Pages 24-27
Bearings, cartridges and pedestals introduction	Pages 28-29
Metric bearings, cartridges and pedestals up to 600mm bore size	Pages 30-49
Inch-size bearings, cartridges and pedestals up to 24" bore size	Pages 50-67
Compatible pedestals introduction	Pages 68-69
SN compatible pedestals	Page 70
SD compatible pedestals	Page 71
SAF compatible pedestals	Page 72
08 SDC SD compatible units	Pages 73-77
Flanges introduction	Pages 78-79
Metric round flange-mounted units	Pages 80-86
Inch-size round flange-mounted units	Pages 87-93
Square flange-mounted units	Pages 94-95
Hangers introduction	Pages 96-97
Metric single and double boss hangers	Pages 98-99

Inch size single and double boss hangers	Pages 100-103
Triple boss hangers	Pages 104-105
Take-up units introduction	Pages 106-107
Metric take-up units, push type	Pages 108-111
Metric take-up units, tension type	Pages 112-115
Inch size take-up units, push-type	Pages 116-121
Inch size take-up units, tension-type	Pages 122-127
Rod-ends introduction	Page 128
Metric rod-ends, T type	Pages 129-131
Metric rod-ends, shoe type	Pages 132-135
Inch size rod-ends, T type	Pages 136-140
Inch size rod-ends, shoe type	Pages 141-145
Bearings over 600mm/24" bore size	Pages 146-147
04 Series bearings	Page 148
Water-cooled bearings	Page 150
Special products	Page 151
Installation and assembly	
Assembly instructions	Pages 152-155
Screw sizes, wrench sizes and torques	Pages 156-160
Grease for initial lubrication	Pages 161-166
Routine greasing	Pages 167-168
What to do with your used bearing	Page 169
Troubleshooting guide	Pages 170-171
Guidance on ordering and part codes	Pages 172-175

Cooper bearings are commonly supplied in two forms: the Fixed Type ('GR') and Expansion Type ('EX') as described below. Where conditions are unsuitable for these standard types other configurations are possible, some of which are described on pages 5 to 7.

Fixed Type Bearings (GR)

The outer race of the fixed (GR) bearing has shoulders integral with the roller track, while the inner race assembly has shoulders formed by hardened lips on the clamping rings or similar integral shoulders.

This type of bearing provides axial location to the rotating portions of machinery and can sustain both radial and axial loading.

The inner race halves are accurately aligned by means of fitted clamping rings.

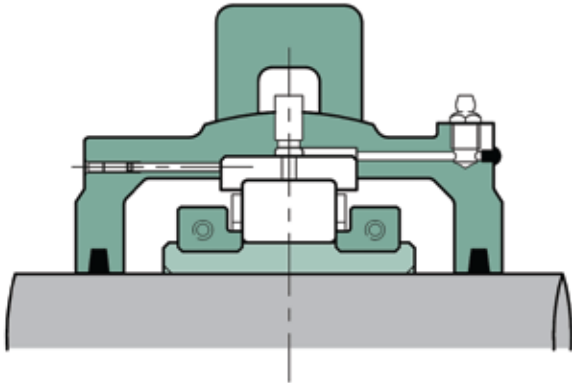

GR Bearing (D Type)

01 and 02 Series through 300mm/12" shaft size
and 03 Series through 155mm /6" shaft size.
100 Series all shaft sizes.

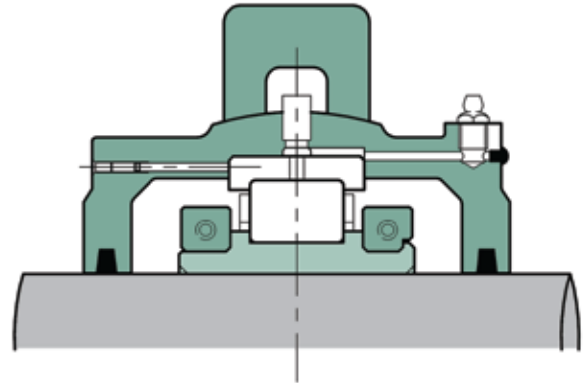

GR Bearing (C Type)

01 and 02 Series over 300mm /12" shaft size
and 03 Series over 155mm /6" shaft size.

4

Expansion Type Bearings (EX)

The expansion (EX) bearing has a plain outer race roller track. This bearing takes radial load only.

The inner race is clamped to the shaft, and moves axially with it when expansion or contraction occurs.

The Cooper expansion bearing offers virtually no resistance to axial movement as the rollers spiral through the outer race.

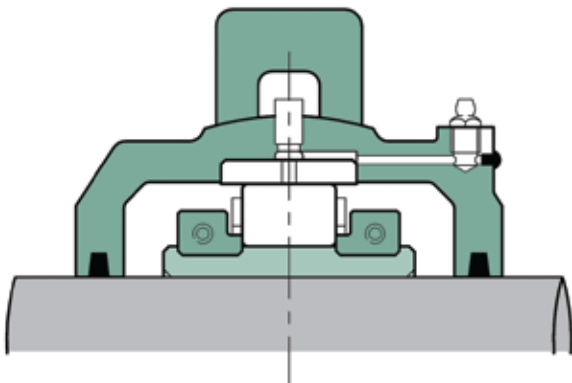

EX Bearing (D Type)

01 and 02 Series through 300mm /12" shaft size
and 03 Series through 155mm /6" shaft size.
100 Series all shaft sizes.

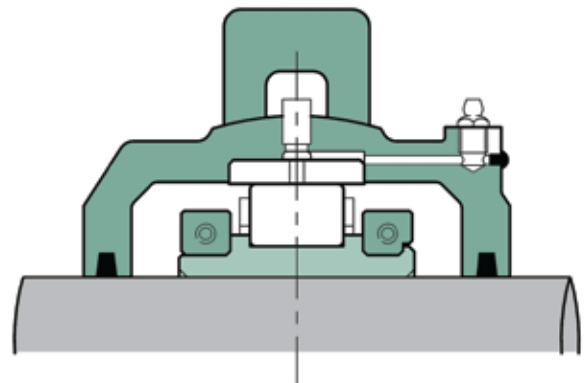

EX Bearing (C Type)

01 and 02 Series over 300mm /12" shaft size
and 03 Series over 155mm/6" shaft size.

Here are some of the alternative configurations we are able to supply where the EX and GR types, shown on the previous page, are unsuitable. If you wish to specify one of these

alternative types, contact our technical department. Please supply details of your application, so we can ensure the most suitable solution is provided.

GR Bearings with Extra Axial Float (AF)

GR bearings can be supplied with the distance between the outer race lips increased to allow limited axial movement of the inner race and shaft.

For larger axial movements GROSL bearings may be required.

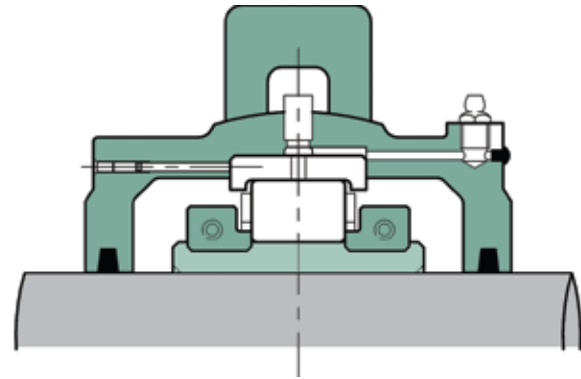

**GR Bearing
with Extra Axial Float**

Single Lipped Bearings (GROSL)

These bearings use a single lip on the outer race to locate the inner race and shaft in one direction only. There is usually clearance between the lip and rollers in the normal running position. Location in both directions is achieved by using two bearings, with lips facing in opposite directions.

Applications include electrical machinery. Here, paired GROSL

bearings are used to limit the movement of the rotor, which is allowed to float axially to run at its magnetic centre.

Overall bearing dimensions are as standard GR & EX types. However, to achieve maximum axial movement, a slight offset between the centrelines of the inner and outer races may be required in the normal running position.

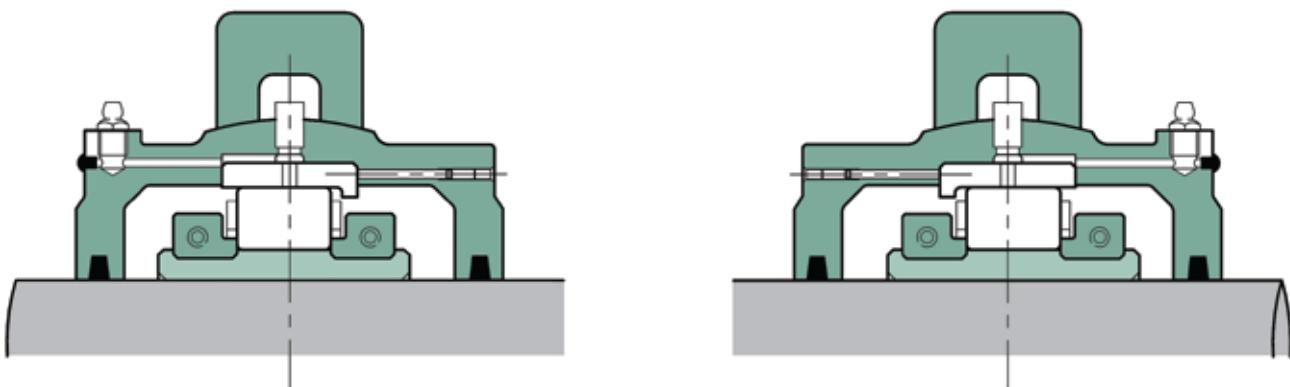

GROSL Bearings

Expansion Bearings with Extra Axial Float (EXILOG)

Where the required axial movement of expansion bearings is greater than is possible with our EX type bearing a special type, with locating outer race and expansion type inner race, can be supplied.

With this type of bearing, the cage and rollers' assembly is located by lips on the outer race. The inner race is without lips, allowing the rollers to spiral across it with virtually no

resistance to axial movement. The inner race is generally wider than those in GR and EX bearings, in order to achieve the increased float.

Large axial movements may be present in applications where the shafts are subjected to large temperature fluctuations or where the shafts are very long.

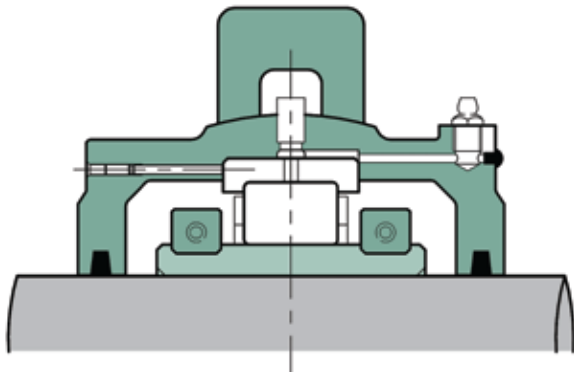

EXILOG Bearing

6

Full Row Bearings

For slow speed applications (up to approximately 10,000 mm dn, depending on size and series) we can supply cageless bearings with a full complement of rollers. These have

the same overall dimensions as standard GR and EX bearings, but have higher dynamic and static capacities. This may allow a lighter series of bearing to be selected (e.g. 01 Series instead of 02 Series) resulting in a more compact, and sometimes more economical solution.

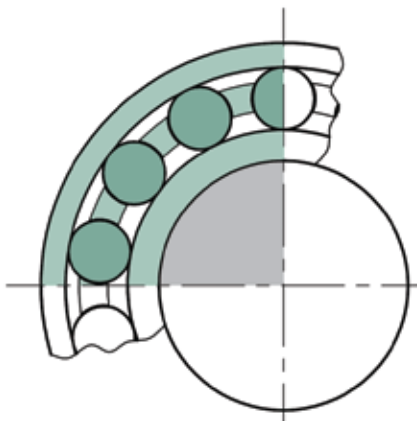

Caged Bearing

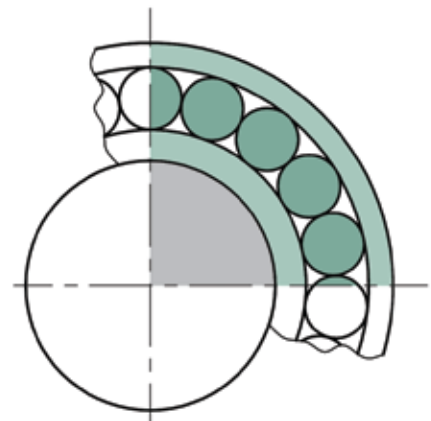

Full Row Bearing

Double Bearings

For increased radial capacity bearings may be supplied as matched pairs for mounting together to form two-row bearings. This is particularly applicable to bore sizes over 600mm.

Another application for double bearings is in link-spindle drives of all sizes, where double bearings are used to ensure correct

bearing alignment in a swivelling yoke supporting the centre of the shaft.

Note: Bearings should only be mounted together to form a two-row bearing if they are supplied by Cooper specifically for this purpose.

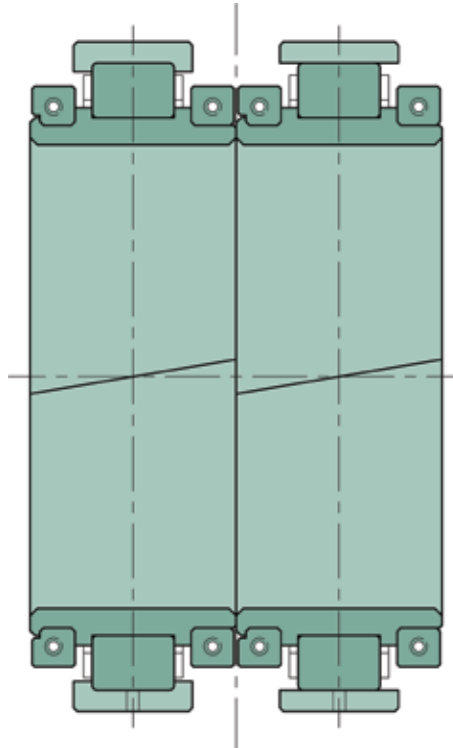

Double Bearing

BEARING MOUNTING OPTIONS

Most styles of Cooper housing are available in cast iron, ductile iron or steel. Special types of housing, alternative materials and housings to special dimensions are available on request.

PEDESTALS

Pedestals (also called pillow blocks) are the most common mountings for Cooper bearings. Detail design and number of fixing bolts varies with bearing series and size.

Cooper offer ranges of pedestals that allow direct replacement of SNC, SD, and SAF pillow block units.

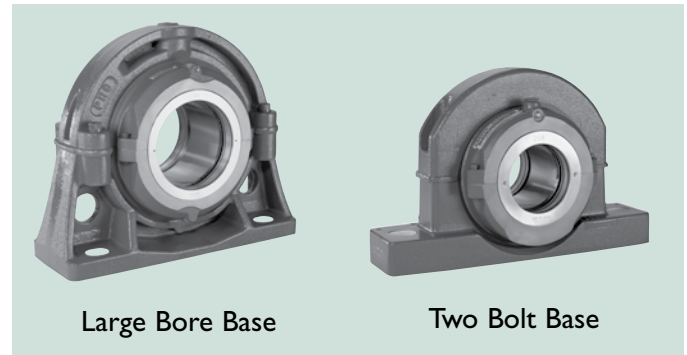

WATERCOOLED HOUSINGS

Bearings in watercooled housings are designed primarily for use in steel mill continuous casters. The low profile housing is either cast or fabricated steel. For more information, please contact our technical department.

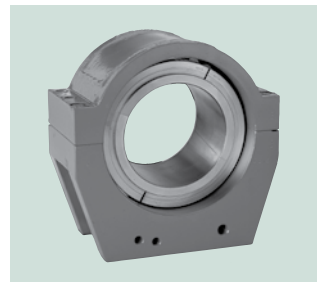

TAKE-UP AND ROD END MOUNTINGS

Take-up units are available as tension type (shown) or push type.

Rod-end units are available as shoe type (shown) or tee type.

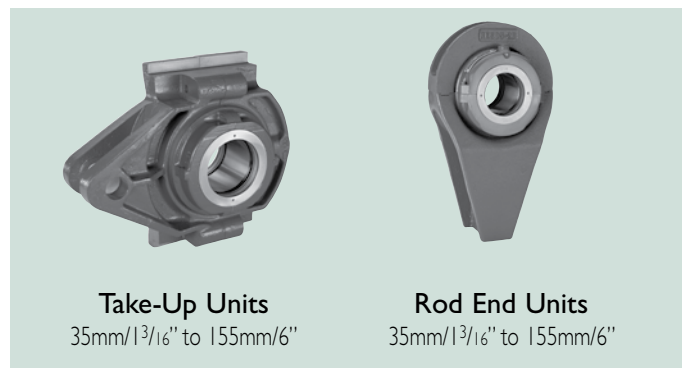

FLANGE MOUNTINGS

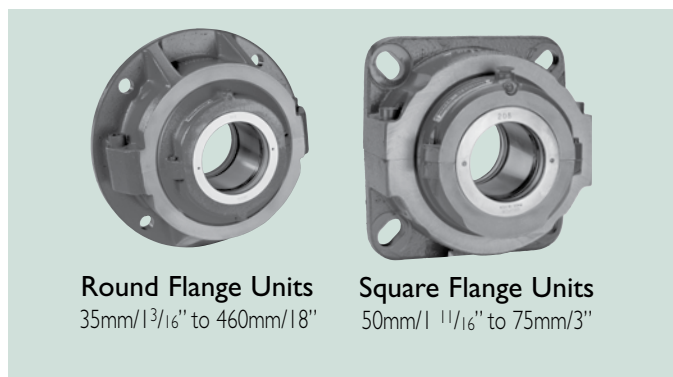

HANGER MOUNTINGS



For most shaft sizes Cooper offers a range of three standard series:

01 Series for medium duties

02 Series for heavy duties

03 Series for extra heavy duties

In the range 45mm to 105mm the 01 Series is superseded by the 01E Series of increased capacity, but with matching envelope dimensions.

For certain bore sizes in the range 75mm to 150mm Cooper also offer the 100 Series. This has slightly lower capacity than 01 Series but is more compact and capable of higher speed operation.

The 04 Series is a specialised range of high speed bearings available in a restricted range of bore sizes from 6 inches to 1550mm.

Bearing references contain the series identification as the prefix numbers in the designation, e.g.:

01 B 120M EX
02 B 120M EX

are bearings of 01 & 02 Series respectively.

This catalogue is laid out with 100, 01/01E, 02 and 03 Series listed together by bore size. This allows you to compare the capacity and speed capabilities, in order to select the most appropriate series.

Generally, if conditions allow and a satisfactory life is theoretically achieved by 01/01E bearings, this series of bearings is the most economical series to select. The 02 and 03 Series are successively higher rated, but are also more expensive in terms of first cost. If high speeds and/or restricted envelope dimensions preclude the use of 01/01E Series, the 100 Series should be selected if other conditions allow.

In the case of an existing bearing being replaced, there may have been other factors than just load capacity involved in the selection of the original bearing. It is often unnecessary to match load capacities of existing bearings to achieve satisfactory bearing life. Wherever possible, the loads on existing bearings should be assessed. This will ensure the most appropriate and economical selection of Cooper bearings to replace them. Cooper can assist with this selection.

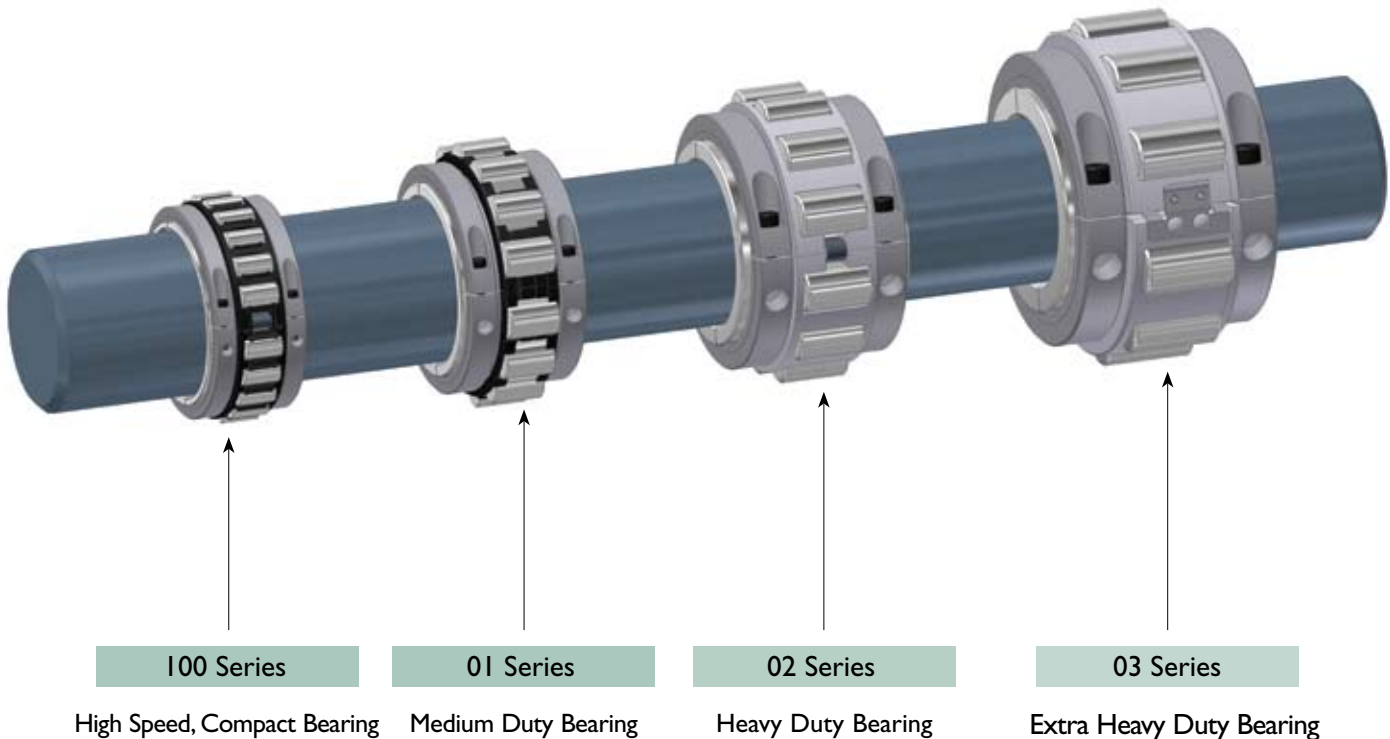

Inner Race Joint Gaps

When the inner race is assembled around a shaft, there should be a small gap at both joints. The gaps at the joints, typically between 0.4mm (0.015") and 0.6mm (0.025") per side, ensure

contact between the bore of the inner race and the shaft. This is illustrated below.

Selection of Internal Bearing Clearance

Cn represents the standard diametral clearance between the rollers and the outer race specified by the International Standards Organisation (ISO) and is usually adequate between -20°C and 100°C and when the temperature difference between the shaft temperature and the housing temperature is less than 40° C.

C2 clearance is less than standard and is used for reciprocating applications or when the shock loads and other conditions demand reduced clearance.

It is limited to a temperature difference of 17°C between shaft and housing temperature since high temperatures cause expansion of the bearing components.

C3 clearance is greater than standard and is typically used when the difference between the shaft and bearing housing surface temperatures is between 40°C and 72°C.

C5 is typically the greatest clearance that Cooper offers. It is used when the difference between the shaft and bearing housing surface temperatures is greater than 72°C.

Cooper does not typically offer a C4 clearance.

Radial load ratings listed in this catalogue are for standard clearance and C2 bearings. Bearings with C3 and C5 clearance have 5% and 10% lower capacity respectively.

For most industrial applications zero clearance is not desirable. Bearings will generate heat as they run. Without clearance, bearings may bind and fail prematurely.

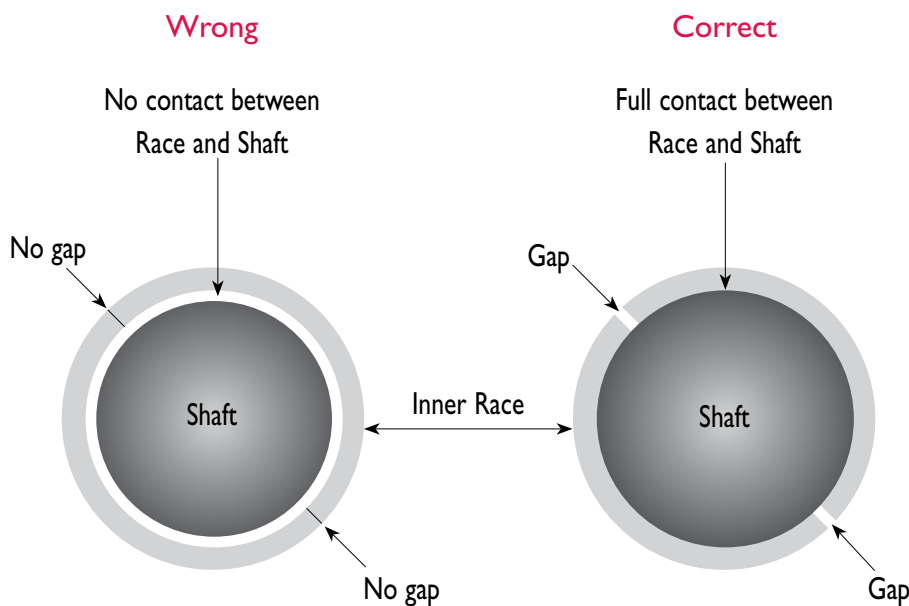

Bearing Selection

Selection of Cooper bearings must take into account both radial and axial loads, which are considered independently as the effect of the axial load on the radial load-bearing surfaces is small enough to discount at normal working loads and speeds.

The thrust or axial load is taken by the end face of the rollers and the flanged shoulders of the inner race assembly and outer race. The ability of the fixed (GR) unit to handle thrust loads is dependent upon specific pressure, velocity of contact areas and lubrication.

Calculating Bearing Loads

The bearing loads are affected by one or more of the following:

- 1 Weight of components such as shafting, flywheels, sheaves, pulleys, gears, etc.
- 2 Tension resulting from belt or chain drives.
- 3 Tangential, separating and axial loading developed by gears.
- 4 Inertia loading resulting from acceleration or deceleration.
- 5 Centrifugal forces developed in rotary or out of balance motion.

Selection for Radial Load

The radial load ratings listed in this catalogue are based on ISO standards. The system establishes a common basis for

calculating load ratings for all anti-friction bearings. The radial load rating is denoted by C_r .

Selection for radial load is determined independently from the axial load. Determine the radial load, speed and minimum life required. Generally the shaft size has been predetermined. Selection of the bearing can be made using the following formula:

$$C_r \geq P \times f_n \times f_L \times f_d.$$

Where C_r = radial dynamic rating.

P = calculated effective radial load.

f_n = speed (rpm) factor:

f_L = life (hours) factor:

f_d = dynamic or service factor:

$$f_n = (\text{rpm} \times 0.03)^{0.3} \text{ or find from scale on page 13.}$$

$$f_L = (\text{L10 hours}/500)^{0.3} \text{ or find from scale on page 13.}$$

L10 hours is the expected life in hours of 90% of similar bearings under similar operating conditions.

Note: The product $f_n \times f_L$ should not be less than 1.0.

Alternatively, bearing life may be calculated by the equation $L_{10} = [C_r / (P \times f_d)]^{10/3}$, where: L_{10} = expected life of 90% of similar bearings under similar operating conditions, in millions of revolutions.

When the equivalent radial load equals the C_r rating, multiplied by the service factor; the L10 life will be 1 million revolutions.

If high temperatures (above 100°C) are involved, please refer to notes on page 13.

Bearing Life Requirements (L)

Suggested lives and factors for specific operating conditions are shown below.

Operating conditions

	Life factor fL	Life hours L10
8 hour daily working	3.0-4.0	20,000- 50,000
Continuous operation main drives, large electrical machinery, flywheels, mining	4.4-5.0	70,000-100,000
Continuous operation and an exceptionally high degree of reliability	5.0-6.0	100,000-200,000

We recommend that bearings are specified to provide an L10 life of at least 10,000 hours, except for bearings selected on the basis of static rating.

Dynamic Factor

The appropriate dynamic factor f_d may be taken from the chart below.

Conditions	f_d
Steady load or small fluctuations	1.0 - 1.3
Light shock	1.3 - 2.0
Heavy shock, vibration or reciprocation	2.0 - 3.5

Life Adjustment Factors for Critical Applications

The basic L10 life obtained by using the equations or tables in this catalogue are adequate for normal applications.

Bearings for most normal applications are specified using the L10 life as above. For reliability greater than 90%, replace L10 in the above equations with L_{na} where $L_{na} = a_1 \times L10$ and is given in the table below.

Reliability %	95	96	97	98	99
a_1	0.62	0.53	0.44	0.33	0.21

Minimum Radial Load

The radial load must exceed a certain value in order to prevent the rollers skidding rather than rolling.

Cooper bearings are able to operate at lower loads than other types of rolling element bearings. Minimum radial loads are generally Cr/65 for GR bearings and Cr/120 for EX bearings. Lower loads can be accommodated under certain conditions. Please refer to our technical department.

Basic Static Load Ratings (Cor)

The values of C_{or} given in this publication have been calculated in accordance with ISO standards. The basic static load rating is defined as that static (radial) load which corresponds to a contact stress of 4,000 MPa (580,000 psi) at the centre of the most heavily loaded roller/raceway contact and produces a permanent deformation of 0.0001 times the roller diameter.

Where rotation is very slow (less than 5 rpm) or intermittent, bearing size can be selected based on the static load carrying capacity. The requisite basic static load rating can be determined from:

$$C_{or} = S_o \times P$$

where:

$$C_{or} = \text{basic static radial load rating (kN)}$$

$$P = \text{effective bearing load (kN)}$$

$$S_o = \text{static safety factor}$$

Bearing Static Safety Factors, S_o

Type of operation	Requirements for smooth running		
	Low	Normal	High
Vibration free	1	1.5	3
Normal	1	2	3.5
High shock loads	2.5	3	4

Selection for Axial Load

Selection for axial load is considered independently from the radial load. Determine the axial load applied to the bearing. Knowing the speed and desired shaft size, select a bearing using the following formula:

$$Ca > (fd_a \times fdn \times Pa) / fb$$

Where Ca = axial rating

fd_a = dynamic or service factor

Pa = calculated axial load

fdn = Velocity (dn) factor

(See scale opposite)

fb = bearing factor (see scale opposite)

The dynamic or service factor fd_a may be 1 for peak overload periods and 1.1 to 1.2 for general running (depending on smoothness), where the load is accurately known. An allowance for any inaccuracies in the calculated loads must be made to ensure that the bearing axial capacity is not exceeded.

Retaining rings or recessed journals are required when $Pa > 0.5Ca$ for 01/01E, 02 and 03 Series bearings, and if $Pa > 0.2Ca$ for 100 Series bearings. See pages 14 and 15.

If the axial load exceeds 40% of the radial load, please consult our technical department.

The axial load capacity is decreased by 50% if the lubricant does not have extreme pressure (EP) additives.

Temperature

The normal range for standard bearings is 0° to 100° C. Where the temperature rise is mainly from the shaft, increased diametric clearance may be necessary (see page 10).

Above 100°C, special consideration must be given to material, design, lubrication and seals. Above 120°C, special heat treatment of the bearing parts is required.

A reduction in radial capacity occurs at temperatures above (150°C) which can be seen below.

°C	170	200	250
% reduction	5	15	25

For temperatures above 100° C or below 0° C, please consult our technical department.

Speed Factor Life Factor Velocity Factor Bearing Factor (fb)

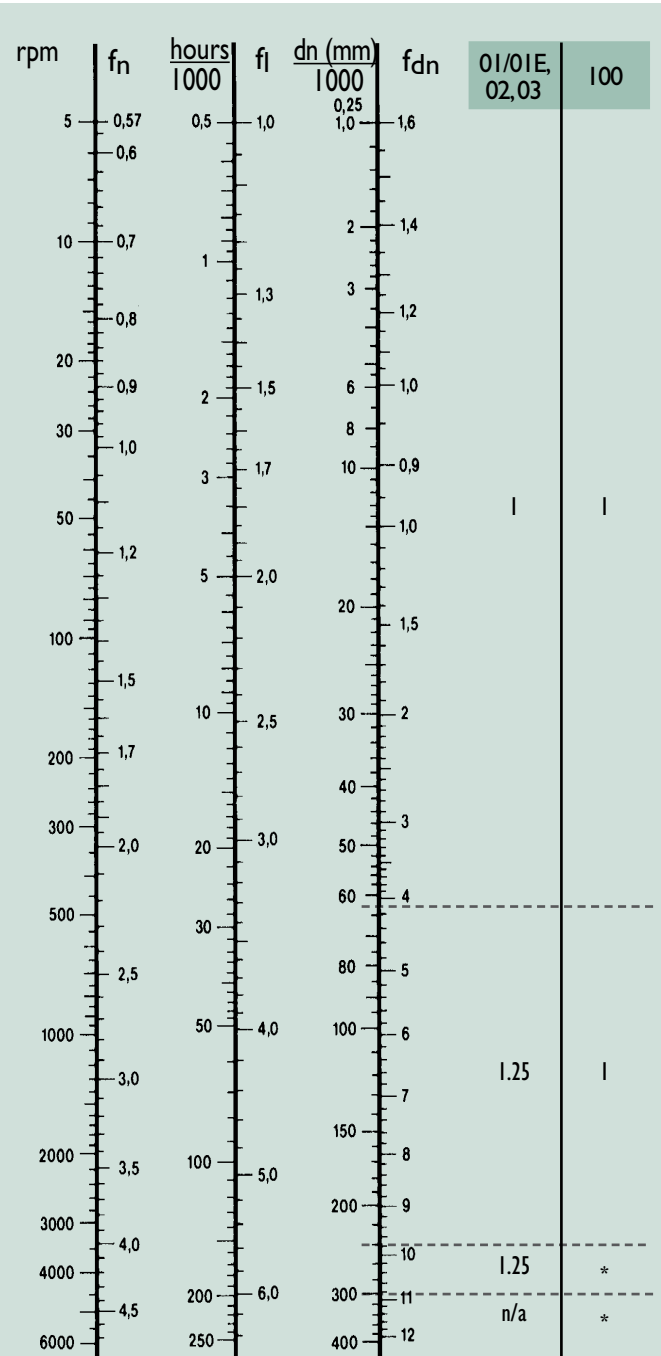

Velocity factor fdn applies only to axial loads on GR bearings.

$$dn \text{ (mm)} = \text{bearing bore (mm)} \times \text{shaft speed (rpm)}$$

* refer to technical department

Shaft Tolerance

Journal diameter tolerance is generally h7.

For speeds over 150,000mm dn and all C2 clearance bearings the tolerance is h6.

For light loads and slow speeds wider tolerances up to h9 may be permissible. Please consult our technical department if a wider tolerance is required, or if it is required to mount a bearing on an existing shaft with a different tolerance to those specified above.

The tolerance on roundness and parallelism of the journal is IT6 in all cases.

Where the shaft is stepped so that the diameter of the shaft at the seals is different to the journal diameter, a wider tolerance (h9) is permissible for the shaft diameter at the seals.

The table below shows relevant tolerances for shaft diameters up to 600mm. The maximum surface roughness of the journal should not exceed 3.2µm Ra when diameter tolerance h7 applies, or 1.6µm Ra when tolerance h6 applies. The maximum surface roughness of the portion of the shaft under the seals is specified on page 20.

Tolerances of Shaft Diameters

Diameter (mm)	Over	-	50	80	120	180	250	315	400	500	
	Up to and incl.	50	80	120	180	250	315	400	500	630	
Tolerance in µm											
Tolerance band (to BS 4500)	h6	+0	+0	+0	+0	+0	+0	+0	+0	+0	+0
		-16	-19	-22	-25	-29	-32	-36	-40	-44	
	h7	+0	+0	+0	+0	+0	+0	+0	+0	+0	+0
		-25	-30	-35	-40	-46	-52	-57	-63	-70	
	h9	+0	+0	+0	+0	+0	+0	+0	+0	+0	+0
IT6	-62	-74	-87	-100	-115	-130	-140	-155	-175		
		16	19	22	25	29	32	36	40	44	

14

Recess Mounting

For fixed (GR) bearings a shaft recess is required if the axial load exceeds 0.5Ca (0.2Ca in the case of I00 Series bearings), or if there is a combination of axial loading and one or more of the following: shock loads, vertical shafts, fluctuating temperatures over 100°C.

Recommended abutment diameters are given below.*

Bearing bore, d	Abutment diameter, D
Up to and incl. 90mm/3½"	d+5mm/d+3/16"
95mm to 155mm/ 3 1/16" to 6"	d+10mm/d+3/8"
Over 155mm/6"	d+10mm/d+3/8"

* Maximum fillet radius (r) may vary according to bearing series. Refer to bearing data pages.

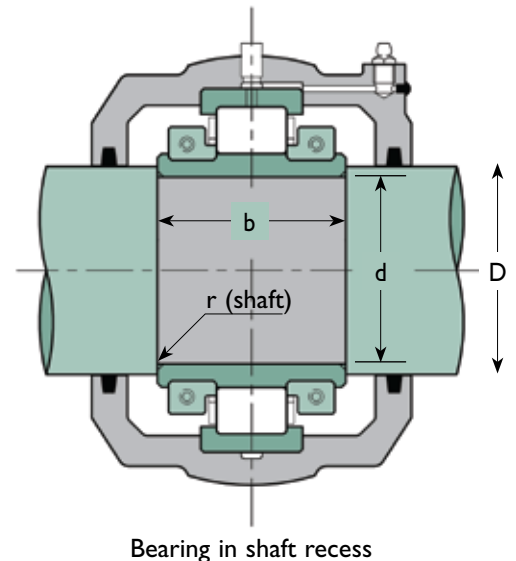

The tolerance on the width of the recess is D11, as per the table below.

Tolerances of Recess Widths

Width (mm)	Over	-	50	80	120	180	250	315
	Up to and incl.	50	80	120	180	250	315	400
Tolerance in μm								
Tolerance D11 to BS 4500		+240	+290	+340	+395	+460	+510	+570
		+80	+100	+120	+145	+170	+190	+210

If larger shaft fillet radii are required we can supply bearings with extra large chamfers to the inner race bores.

Note that recess mounting requires a special cartridge and seals to accommodate the larger shaft diameters. On some sizes a modified inner race is also required to allow the races halves to be assembled onto the shaft in a truly radial direction.

(With standard races it is sometimes necessary to incline the race half slightly to the shaft axis in order to get it into position, but this is prevented by the walls of the recess.) If the bearing is to be mounted in a shaft recess please inform our technical department so that they can advise on the required modifications and part codes.

Retaining Rings

An alternative to recess mounting is to locate the inner race with retaining rings. Select retaining rings to accommodate the full axial load according to the manufacturer's data, and machine the grooves for the retaining rings as per the manufacturer's instructions.

The rings must be spaced so as to provide a journal width of D11 tolerance.

Note that the bore of the inner race has a chamfer. The retaining rings must be of sufficient diameter to abut effectively onto the parallel end faces of the inner race. The rings must not be excessively wide so as to interfere with the seals. In general it is permissible to locate the inner race of a GR bearing using retaining rings of a width up to half the total available axial movement of the equivalent EX bearing as specified in this catalogue.

With this arrangement standard cartridges and seals may be used.

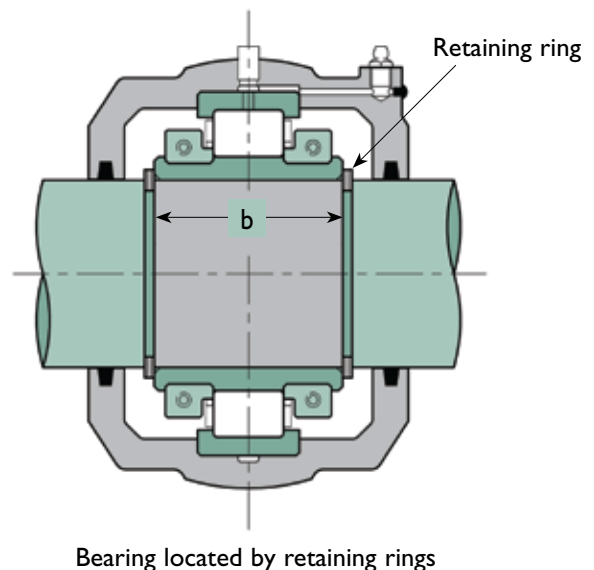

Bearing frequency data are included in this catalogue for two purposes:

- to allow machine designers to check excitation frequencies against resonant frequencies in the machine,
- to allow correct input into condition monitoring equipment that uses this data.

Bearing Geometry and Frequencies of Bearing Parts

A roller bearing will excite vibrations at certain frequencies related to the number, size and pitch circle diameter of the rollers. To some extent this excitation is present even with new bearings in perfect condition, as the load is carried on discrete, elastic, rolling elements which are constantly changing in angular position.

The tables opposite and on the following pages indicate the frequencies of bearing parts per shaft revolution, which can be used to calculate excitation frequencies directly by multiplying the tabulated frequencies by the shaft speed.

The frequencies listed are explained as follows:

‘Cage’ – the frequency at which a point on the cage enters and leaves the loaded zone of the bearing.

‘Roller’ – the frequency at which a point on a given roller passes into contact with either the inner or outer race.

‘Outer’ – the frequency at which a point on the outer race comes into contact with successive rollers.

‘Inner’ – the frequency at which a point on the inner race comes into contact with successive rollers.

The tables also list the pitch circle diameters and number of rollers, for use with condition monitoring equipment that accepts this information.

Note that the contact angle is 0 in all cases.

Vibration levels

Velocity readings for a properly installed new bearing may be as high as 4mm/second.

Typically, alarm levels should be set no higher than 15mm/second.

Shutdown level should be set no higher than 20mm/second.

Shaft Diameter d	Bearing Reference	Part Frequencies (per shaft rev.)				Roller details		
		Cage	Roller	Outer	Inner	PCD (mm)	No.	Diameter (mm)
35	01 B 35M	0.405	2.538	4.051	5.949	62.71	10	11.91
40	01 B 40M	0.405	2.538	4.051	5.949	62.71	10	11.91
45	01E B 45M	0.415	2.857	4.980	7.020	76.50	12	13.00
50	01E B 50M	0.415	2.857	4.980	7.020	76.50	12	13.00
	02 B 50M	0.402	2.452	4.020	5.980	80.96	10	15.88
55	01E B 55M	0.417	2.934	5.840	8.160	90.50	14	15.00
60	01E B 60M	0.417	2.934	5.840	8.160	90.50	14	15.00
	02 B 60M	0.411	2.730	4.936	7.064	98.43	12	17.46
65	01E B 65M	0.417	2.934	5.840	8.160	90.50	14	15.00
	02 B 65M	0.411	2.730	4.936	7.064	98.43	12	17.46
70	01E B 70M	0.420	3.053	5.883	8.117	106.50	14	17.00
	02 B 70M	0.411	2.719	4.932	7.068	115.89	12	20.64
75	100 B 75M	0.448	4.723	8.953	11.047	95.50	20	10.00
	01E B 75M	0.420	3.053	5.883	8.117	106.50	14	17.00
	02 B 75M	0.411	2.719	4.932	7.068	115.89	12	20.64
80	01E B 80M	0.423	3.187	6.774	9.226	124.00	16	19.00
	02 B 80M	0.417	2.917	5.833	8.167	133.35	14	22.23
85	100 B 85M	0.446	4.592	8.924	11.076	111.50	20	12.00
	01E B 85M	0.423	3.187	6.774	9.226	124.00	16	19.00
	02 B 85M	0.417	2.917	5.833	8.167	133.35	14	22.23
90	01E B 90M	0.423	3.187	6.774	9.226	124.00	16	19.00
	02 B 90M	0.417	2.917	5.833	8.167	133.35	14	22.23
95	01E B 95M	0.422	3.138	6.756	9.244	141.50	16	22.00
100	100 B 100M	0.446	4.553	8.915	11.085	129.00	20	14.00
	01E B 100M	0.422	3.138	6.756	9.244	141.50	16	22.00
	02 B 100M	0.417	2.917	5.833	8.167	152.40	14	25.40
	03 B 100M	0.384	2.038	3.839	6.161	177.80	10	41.28
105	01E B 105M	0.422	3.138	6.756	9.244	141.50	16	22.00
	02 B 105M	0.417	2.917	5.833	8.167	152.40	14	25.40
110	100 B 110M	0.442	4.251	8.840	11.160	146.50	20	17.00
	01 B 110M	0.430	3.501	6.880	9.120	158.75	16	22.23
	02 B 110M	0.417	2.917	5.833	8.167	171.45	14	28.58
	03 B 110M	0.392	2.199	3.917	6.083	190.50	10	41.28
115	01 B 115M	0.430	3.501	6.880	9.120	158.75	16	22.23
	02 B 115M	0.417	2.917	5.833	8.167	171.45	14	28.58

Shaft Diameter d	Bearing Reference	Part Frequencies (per shaft rev.)				Roller details		
		Cage	Roller	Outer	Inner	PCD (mm)	No.	Diameter (mm)
120	100 B 120M	0.447	4.627	8.932	11.068	163.46	20	17.46
	01 B 120M	0.432	3.599	6.909	9.091	174.63	16	23.81
	02 B 120M	0.417	2.917	5.833	8.167	190.50	14	31.75
	03 B 120M	0.392	2.199	3.917	6.083	190.50	10	41.28
125	01 B 125M	0.432	3.599	6.909	9.091	174.63	16	23.81
	02 B 125M	0.417	2.917	5.833	8.167	190.50	14	31.75
130	100 B 130M	0.447	4.627	8.932	11.068	163.46	20	17.46
	01 B 130M	0.432	3.599	6.909	9.091	174.63	16	23.81
	02 B 130M	0.417	2.917	5.833	8.167	190.50	14	31.75
	03 B 130M	0.398	2.360	4.781	7.219	203.20	12	41.28
135	01 B 135M	0.433	3.683	6.933	9.067	190.50	16	25.40
140	100 B 140M	0.447	4.654	8.938	11.062	179.33	20	19.05
	01 B 140M	0.433	3.683	6.933	9.067	190.50	16	25.40
	02 B 140M	0.419	3.014	5.869	8.131	206.38	14	33.34
	03 B 140M	0.393	2.226	4.714	7.286	222.25	12	47.63
145	02 B 145M	0.419	3.014	5.869	8.131	206.38	14	33.34
150	100 B 150M	0.443	4.300	8.852	11.148	193.68	20	22.23
	01 B 150M	0.438	3.938	7.875	10.125	203.20	18	25.40
	02 B 150M	0.421	3.103	6.743	9.257	222.25	16	34.93
	03 B 150M	0.395	2.270	4.737	7.263	241.30	12	50.80
155	01 B 155M	0.438	3.938	7.875	10.125	203.20	18	25.40
	02 B 155M	0.421	3.103	6.743	9.257	222.25	16	34.93
160	01 B 600-160M	0.438	3.938	7.875	10.125	203.20	18	25.40
	01 B 160M	0.438	3.997	7.891	10.109	219.08	18	26.99
	02 B 600-160M	0.421	3.103	6.743	9.257	222.25	16	34.93
	02 B 160M	0.421	3.088	5.895	8.105	241.30	14	38.10
170	03 B 160M	0.409	2.642	5.720	8.280	260.35	14	47.63
	01 B 608-170M	0.438	3.997	7.891	10.109	219.08	18	26.99
	01 B 170M	0.442	4.236	8.836	11.164	231.78	20	26.99
	02 B 170M	0.421	3.088	5.895	8.105	241.30	14	38.10
175	03 B 170M	0.409	2.642	5.720	8.280	260.35	14	47.63
	01 B 175M	0.442	4.236	8.836	11.164	231.78	20	26.99
180	02 B 175M	0.425	3.258	6.800	9.200	254.00	16	38.10
	01 B 180M	0.442	4.236	8.836	11.164	231.78	20	26.99
180	02 B 180M	0.425	3.258	6.800	9.200	254.00	16	38.10
	03 B 180M	0.411	2.717	5.753	8.247	276.23	14	49.21

Shaft Diameter d	Bearing Reference	Part Frequencies (per shaft rev.)				Roller details		
		Cage	Roller	Outer	Inner	PCD (mm)	No.	Diameter (mm)
190	01 B 190M	0.448	4.712	9.846	12.154	257.18	22	26.99
	02 B 190M	0.428	3.389	6.844	9.156	285.75	16	41.28
	03 B 190M	0.413	2.796	5.786	8.214	311.15	14	53.98
200	01 B 200M	0.448	4.712	9.846	12.154	257.18	22	26.99
	02 B 200M	0.428	3.389	6.844	9.156	285.75	16	41.28
	03 B 200M	0.413	2.796	5.786	8.214	311.15	14	53.98
220	01 B 220M	0.450	4.950	9.900	12.100	285.75	22	28.58
	02 B 220M	0.434	3.703	7.806	10.194	311.15	18	41.28
	03 B 220M	0.414	2.808	4.964	7.036	349.25	12	60.33
230	01 B 230M	0.450	4.950	9.900	12.100	285.75	22	28.58
	02 B 230M	0.434	3.703	7.806	10.194	311.15	18	41.28
240	01 B 240M	0.455	5.455	11.818	14.182	314.33	26	28.58
	02 B 240M	0.435	3.792	7.833	10.167	342.90	18	44.45
	03 B 240M	0.418	2.971	5.853	8.147	368.30	14	60.33
250	01 B 250M	0.455	5.455	11.818	14.182	314.33	26	28.58
	02 B 250M	0.435	3.792	7.833	10.167	342.90	18	44.45
	03 B 250M	0.418	2.971	5.853	8.147	368.30	14	60.33
260	01 B 1000-260M	0.455	5.455	11.818	14.182	314.33	26	28.58
	01 B 260M	0.454	5.354	10.889	13.111	342.90	24	31.75
	02 B 260M	0.435	3.792	7.833	10.167	342.90	18	44.45
	03 B 260M	0.418	2.971	5.853	8.147	368.30	14	60.33
270	01 B 270M	0.454	5.354	10.889	13.111	342.90	24	31.75
275	01 B 275M	0.454	5.354	10.889	13.111	342.90	24	31.75
280	01 B 280M	0.454	5.354	10.889	13.111	342.90	24	31.75
	02 B 280M	0.436	3.836	7.846	10.154	371.48	18	47.63
	03X B 280M	0.425	3.240	6.794	9.206	400.05	16	60.33
	03E B 280M	0.423	3.160	6.764	9.236	390.53	16	60.33
290	01 B 290M	0.457	5.807	11.889	14.111	371.48	26	31.75
	03 B 290M	0.426	3.326	6.824	9.176	431.80	16	63.50
300	01 B 300M	0.457	5.807	11.889	14.111	371.48	26	31.75
	02 B 300M	0.440	4.140	8.810	11.190	400.05	20	47.63
	03 B 300M	0.426	3.326	6.824	9.176	431.80	16	63.50
320	01 B 320M	0.458	5.910	11.908	14.092	396.88	26	33.34
	02 B 320M	0.443	4.297	8.852	11.148	428.63	20	49.21
	03 B 320M	0.423	3.184	5.927	8.073	476.20	14	73.03

VIBRATION DATA

Shaft Diameter d	Bearing Reference	Part Frequencies (per shaft rev.)				Roller details		
		Cage	Roller	Outer	Inner	PCD (mm)	No.	Diameter (mm)
330	01 B 330M	0.458	5.910	11.908	14.092	396.88	26	33.34
	02 B 330M	0.443	4.297	8.852	11.148	428.63	20	49.21
340	01 B 1300-340M	0.458	5.910	11.908	14.092	396.88	26	33.34
	01 B 340M	0.461	6.294	12.895	15.105	422.28	28	33.34
	02 B 340M	0.443	4.337	8.862	11.138	460.38	20	52.39
	03E B 340M	0.428	3.405	6.850	9.150	485.78	16	69.85
350	01 B 350M	0.461	6.294	12.895	15.105	422.28	28	33.34
	02 B 350M	0.443	4.337	8.862	11.138	460.38	20	52.39
360	01 B 1400-360M	0.461	6.294	12.895	15.105	422.28	28	33.34
	01 B 360M	0.461	6.416	12.915	15.085	450.85	28	34.93
	02 B 360M	0.443	4.337	8.862	11.138	460.38	20	52.39
	03E B 360M	0.428	3.405	6.850	9.150	485.78	16	69.85
	03X B 360M	0.427	3.362	6.835	9.165	501.65	16	73.03
380	01 B 380M	0.461	6.416	12.915	15.085	450.85	28	34.93
	02 B 380M	0.446	4.552	9.806	12.194	482.60	22	52.39
	03 B 380M	0.429	3.429	6.857	9.143	533.40	16	76.20
390	01 B 390M	0.463	6.782	13.900	16.100	476.25	30	34.93
400	01 B 400M	0.463	6.782	13.900	16.100	476.25	30	34.93
	02 B 400M	0.447	4.682	9.839	12.161	511.18	22	53.98
	03 B 400M	0.429	3.429	6.857	9.143	533.40	16	76.20
420	01 B 420M	0.465	7.147	14.886	17.114	501.65	32	34.93
	02 B 420M	0.449	4.806	9.868	12.132	539.75	22	55.56
	03E B 420M	0.435	3.759	8.693	11.307	566.00	20	74.00
440	01 B 440M	0.467	7.512	15.873	18.127	527.05	34	34.93
	02 B 440M	0.451	5.008	10.814	13.186	561.98	24	55.56
	03E B 440M	0.435	3.759	8.693	11.307	566.00	20	74.00
460	01 B 460M	0.467	7.512	15.873	18.127	527.05	34	34.93
	02 B 460M	0.451	5.008	10.814	13.186	561.98	24	55.56
	03E B 460M	0.433	3.683	7.800	10.200	600.00	18	80.00
	03X B 460M	0.432	3.598	6.909	9.091	628.65	16	85.73
480	01 B 480M	0.467	7.576	14.949	17.051	555.63	32	36.51
	02 B 480M	0.453	5.267	11.777	14.223	590.55	26	55.56
	03X B 480M	0.432	3.598	6.909	9.091	628.65	16	85.73
500	01 B 500M	0.469	7.925	15.932	18.068	581.03	34	36.51
	02 B 500M	0.455	5.469	12.731	15.269	612.78	28	55.56
	03 B 500M	0.437	3.900	7.864	10.136	679.45	18	85.73

Shaft Diameter d	Bearing Reference	Part Frequencies (per shaft rev.)				Roller details		
		Cage	Roller	Outer	Inner	PCD (mm)	No.	Diameter (mm)
530	01 B 530M	0.470	8.362	16.927	19.073	612.78	36	36.51
	02 B 530M	0.453	5.322	11.789	14.211	647.70	26	60.33
	03 B 530M	0.437	3.900	7.864	10.136	679.45	18	85.73
560	01 B 560M	0.471	8.711	17.913	20.087	638.18	38	36.51
	02 B 560M	0.455	5.561	12.751	15.249	676.28	28	60.33
	03E B 560M	0.440	4.107	8.800	11.200	714.38	20	85.73
580	01 B 580M	0.471	8.721	17.914	20.086	666.75	38	38.10
	02 B 580M	0.461	6.432	13.841	16.159	698.50	30	53.98
600	01 B 600M	0.472	9.056	18.899	21.101	692.15	40	38.10
	02 B 600M	0.458	5.958	13.750	16.250	723.90	30	60.33
	03E B 600M	0.442	4.244	9.722	12.278	740.00	22	86.00

Efficient performance and long life of the roller bearing depend to a large extent upon the exclusion of foreign matter from the internal bearing surfaces. Grease, or oil, serves the dual purpose of lubricating these surfaces and protecting them from corrosion. Thus the seal must prevent dust, grit and moisture from entering the bearing and at the same time prevent grease or oil from escaping.

Alignment feature

Cooper supplies various mounting options and for all, except the hanger mountings, the bearing is housed in a cartridge supported by the mounting unit. Cartridges have a spherical outer surface that fits into a conforming surface in the mounting unit (such as pedestal or flange) in the manner of a ball and socket joint.

Any shaft misalignment that may exist tends to move the cartridge, seal and bearing together, maintaining the seal on an axis parallel to the shaft. Standard pedestals and flanges are designed to allow up to $2\frac{1}{2}^\circ$ misalignment between the shaft and housing, under constant or slowly changing alignment conditions, without compromising sealing.

Compare this with the situation that occurs with a double row spherical bearing in a standard pedestal. If the pedestal is not accurately aligned with the shaft, contact between the seal and the shaft tends to be lost at one side, and the seal presses more heavily against the shaft at the other. In the worst case a gap may open, compromising the sealing, or the seal may bind on the shaft. Although felt seals are shown in the illustration, a similar situation occurs with labyrinth or lip seals.

Seal types

Cartridges for shaft sizes up to 300mm/12" are usually supplied with a general purpose felt seal. The felt groove will also accommodate high temperature packing seals, lipped seals or suitable blanking plates.

Triple labyrinth seals are often supplied as an alternative and are precision non-rubbing seals capable of high speed operation. Due to the aligning feature described above, extremely close tolerances can be maintained between the housing and the shaft. The result is an effective sealing element which is one of the best in the anti-friction bearing industry.

Cartridges for shaft sizes over 300mm/12" are supplied with grease groove seals as standard.

Cooper offer a wide range of sealing options, the more common of which are illustrated overleaf. For special applications seals may be made from other materials and alternative special seals can be supplied to suit specific conditions.

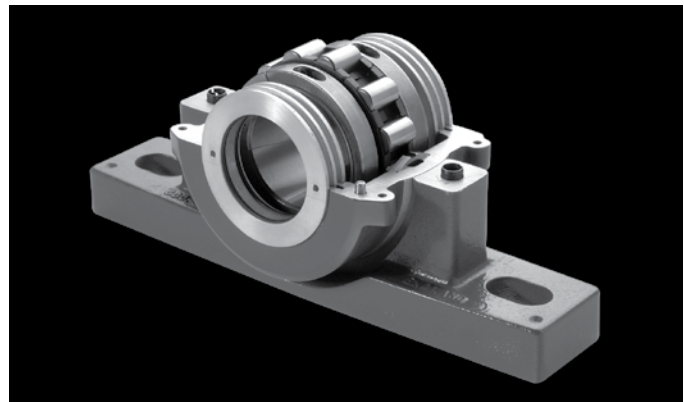

This picture illustrates an aluminium triple labyrinth seal on an 01E Series bearing and cartridge.

The twin 'O' rings are visible in the bore of the seal. The compression of the 'O' rings causes the seal to rotate with the shaft, but the amount of compression is so designed that the shaft moves through the seal when axial expansion occurs in EX bearings.

Cooper Split Roller Bearing

Double Row Spherical Bearing

Seal remains parallel to the shaft

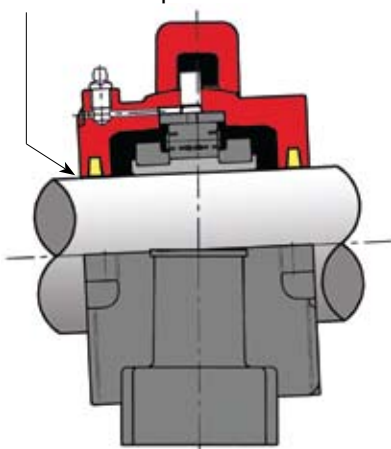

Gap between seal and shaft

Seal binds

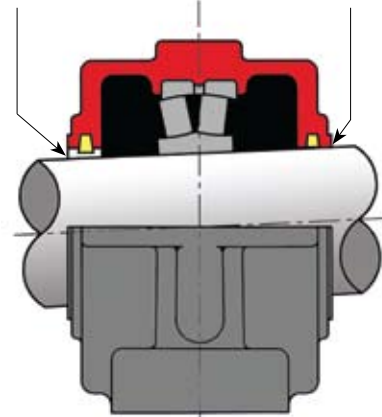

Felt (F)

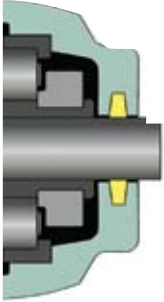

Made from wool and selected fibres. Felt is the current UK and European standard seal for bearings up to 300mm/12" bore size.

Temperature limits	-70°C to +100°C
Maximum speed	150000mm dn
Shaft surface finish	1.6µm Ra max.

High Temperature Packing (HTP)

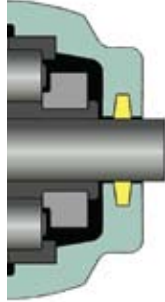

A PTFE filament yarn impregnated with graphite and lubricated with silicon. A direct replacement for felt in high temperature applications. Also available silicon free.

Temperature limits	-70°C to +260°C
Maximum speed	150000mm dn
Shaft surface finish	0.8µm Ra max.

Labyrinth grease groove (LAB)

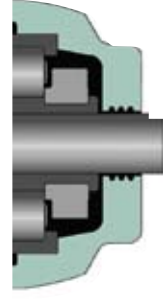

Standard seal for bearings over 12"/300mm. Particularly successful on marine applications. Suitable for low or high speed operation.

Temperature limits	As bearing
Maximum speed	As bearing
Shaft surface finish	3.2µm Ra max.

Aluminium Triple Labyrinth (ATL)

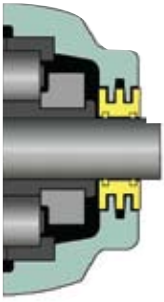

Machined aluminium bodied triple labyrinth seal for high speed and general applications. Supplied as standard in USA and Canada.

Temperature limits	-20°C to +100°C
Maximum speed	Bearing maximum
Shaft surface finish	3.3µm Ra max.

Triple labyrinth with Viton rubber cord insert (ATL HT)

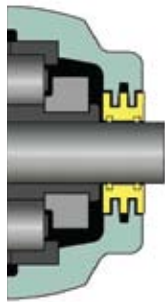

Suitable for high speed and high temperature applications.

Temperature limits	-20°C to +175°C
Maximum speed	Bearing maximum
Shaft surface finish	3.2µm Ra max.

Neoprene rubber triple labyrinth (NTL)

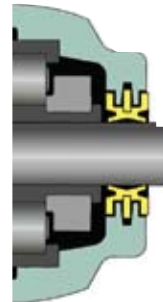

Can be used where an explosive or corrosive atmosphere prevents the use of aluminum.

Temperature limits	-20°C to +100°C
Maximum speed:	
Shaft diameters up to 65mm:	3300rpm
Shaft diameters from 70mm to 90mm:	2000rpm
Shaft diameters from 95mm to 105mm:	1800rpm
Shaft surface finish	3.2µm Ra max.

Synthetic nitrile rubber single lip (SRS)*

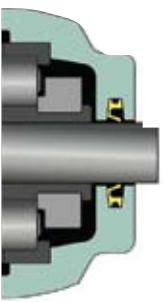

For wet but not submerged applications. Can be used to retain bearing lubricant by mounting lip innermost.

Temperature limits	-20°C to +100°C
Maximum speed	150000mm dn
Shaft surface finish	0.8µm Ra max.

Single lip with spring loaded retaining plate (SRSRP)

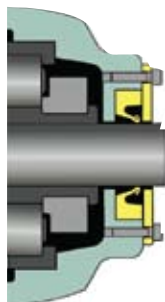

Suitable for severe splash or completely submerged applications. Two grades are available, one operates up to 2 metres of fluid the other up to 30 metres.

Temperature limits	-20°C to +100°C
Maximum speed	150000mm dn
Shaft surface finish	0.4µm Ra max.

* High and low temperature versions also available.

SEAL SELECTION

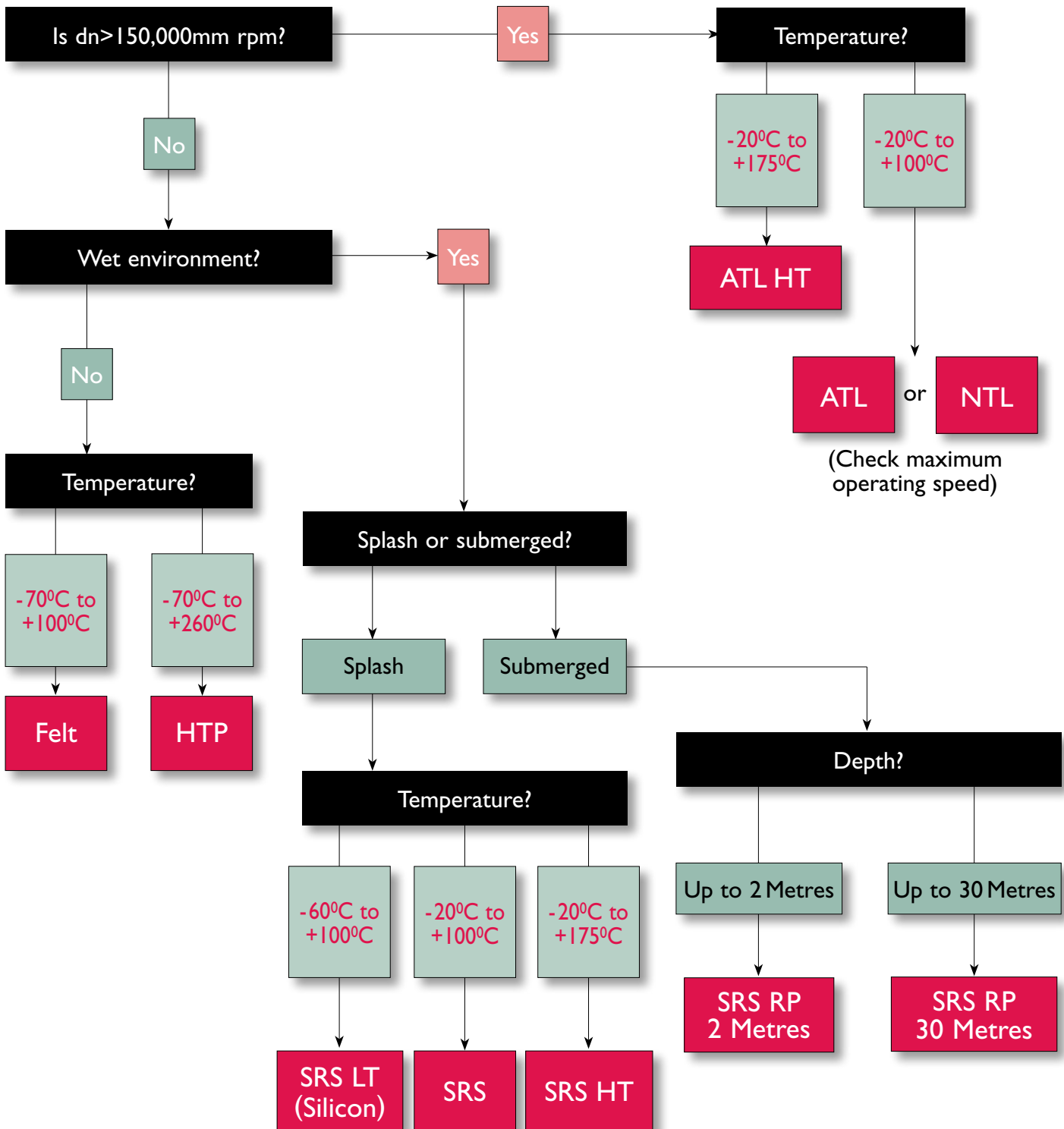

Where shafts terminate at the bearings, 'blanking plates' may be used to close off the cartridge ends.

Blanking plates are available to suit standard single groove and TL cartridges.

On sizes up to 90mm/3½" blanking plates accommodating thrust bearings can be used for axial location of shafts. A typical application is on the shafts of belt conveyors.

For blanking plates with thrust bearings, the shaft ends must be machined smooth and square. Upon assembly, there must be slight clearance between the shaft ends and the thrust bearings (i.e. slight end float), without the possibility of preload.

Blanking plates with thrust bearings are limited to a maximum speed of 20,000mm dn (calculated using the shaft size, not the bore of the thrust bearing) and to shaft location only (i.e. only nominal axial loading).

Dimensions

Dimensions for shaft terminations, when using blanking plates with thrust bearings, are shown below:

Shaft diameter d		01 Series		02 Series	
		K	t	K	t
35mm	1⅜"	27	2	-	-
	1¼"				
40mm	1⅞"	29	1	-	-
	1½"				
45mm	1⅞"	29	1	-	-
	1¾"				
50mm	1⅝"	29	1	35	1
	2"				
55mm		30	2	-	-
60mm	2⅜"	30	2	38	2
	2¼"				
65mm	2⅞"	35	4	41	0
	2½"				
70mm	2⅞"	40	4	48	3
	2¾"				
75mm	2⅝"	40	4	48	3
	3"				
80mm	3⅜"	40	4	48	3
85mm	3¼"				
90mm	3⅞"	40	4	48	3
	3½"				

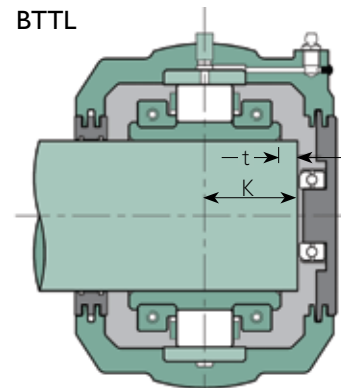
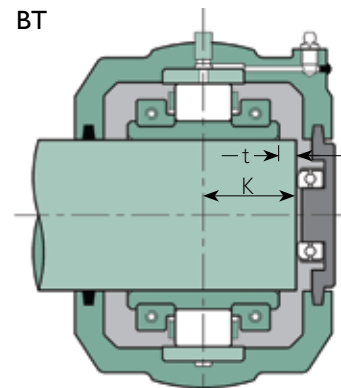
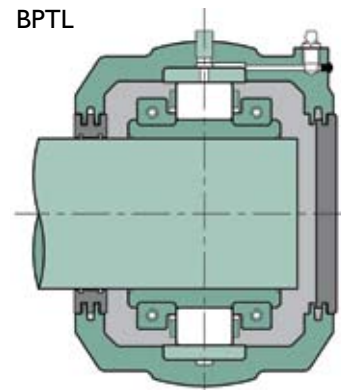
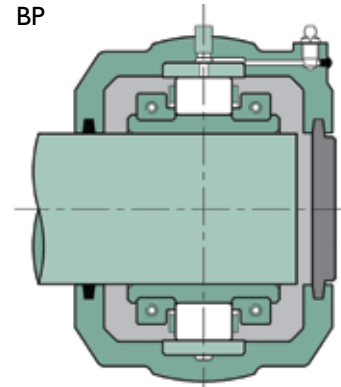

Ordering

For blanking plates to suit single groove cartridges, the part code is made up as follows:

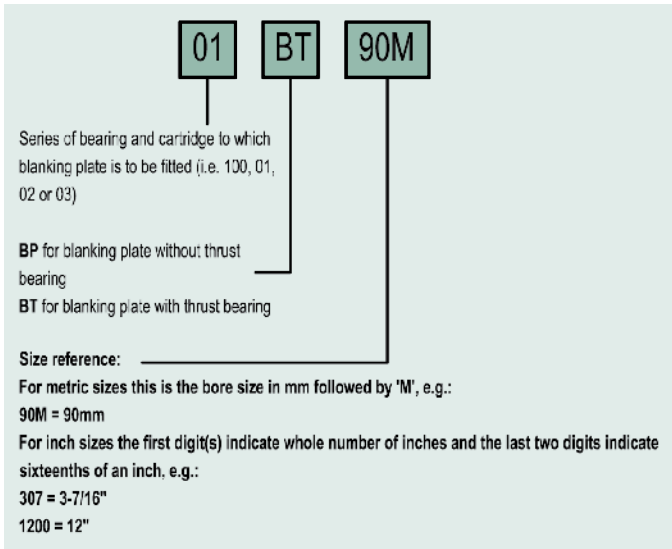

For blanking plates to suit TL cartridges, the part code is made up as follows:

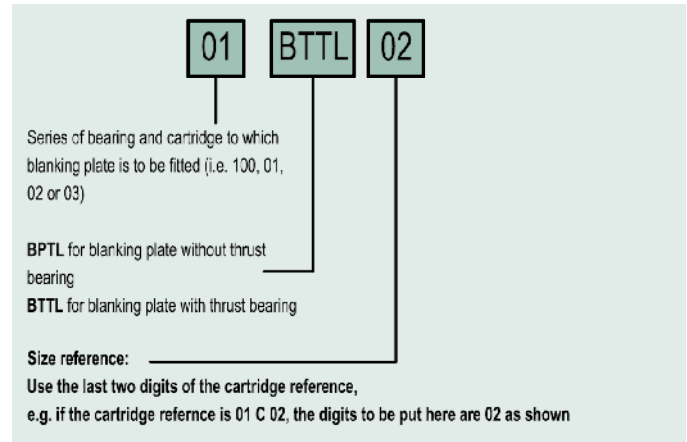

BT and BTTL blanking plates are only regarded as standard items for 01 and 02 series cartridges up to 90mm/3 1/2" bore size.

For all blanking plates, if the cartridge end bore is machined to suit a shaft diameter that is different to the bore of the bearing, refer to Cooper for the relevant part code.

Bearing Lubrication

Friction and wear are reduced by separating rollers and races with a lubricant film to minimise metal to metal contact. The major factors in selecting a lubricant are speed, lubricant base oil, viscosity and temperature.

As speed and viscosity increase, thickness of lubricant film increases. As temperature increases, lubricant film thickness decreases. The lubricant film should be sufficient to cover the average peaks on the bearing surface by a ratio of at least 1.25. As the ratio falls below 1.25, some metal to metal contact will occur with a corresponding loss of L10 life.

This situation should not occur if the lubricant is selected according to the method given on page 25.

Grease Lubrication

Standard cartridges are designed for grease lubrication, lubrication points are tapped 1/8" NPT or 1/4" NPT depending on size, and fitted with grease nipples. Alternative tappings or fittings are available on request.

Grease lubrication is easier to retain in the bearing than oil, offering lower lubricant losses and improved sealing. Grease also offers better protection against corrosion to the rolling surfaces.

A grease typically consists of three components; a thickener (sometimes called a soap), a base oil and additives. The oil in the grease has an ISO-VG rating. In most cases, this is the key to selecting the grease. At speeds in excess of 200,000mm dn, greases with synthetic base oils are recommended. Please consult our technical department for proper grease selection.

The National Lubricating Grease Institute (NLGI) has designated consistency grades for greases based upon the amount of thickener in the grease. The standard recommended grease for Cooper is a No.2 or No.3 consistency grade with an EP additive. The exception to this is a centrally pumped system where a No.1 is used for "pumpability".

A lithium complex thickener is used for normal applications operating at temperatures between 0°C and 80°C. When water resistance is required, an aluminium complex thickener can be used. Aluminium complex greases are not compatible with some other types of grease. The bearing must therefore be solvent cleaned of other greases prior to adding an aluminium complex based grease.

The initial pack of grease depends on speed. The initial pack should be used to coat the rolling surfaces of the bearing during installation. Further information is to be found on page 161.

For extreme temperatures, speeds and loads always obtain a lubricant selection from our technical department.

Oil Lubrication

Oil lubrication can be broken down into three major categories; recirculating oil systems, constant level and oil mist.

Recirculating oil systems use a pump to provide a continuous flow of oil to the bearing which is then recaptured, cooled, filtered and recirculated.

A constant level oiler is the simplest method for delivery of oil lubrication to a bearing. The oiler maintains a constant level in the bottom of the bearing. Ideal conditions for oiler use would be bearing temperature less than 60°C and downwards load with low to moderate speeds.

An oil mist system uses compressed air to atomise oil and spray it into the bearing. Conveying oil with filtered air maintains a positive pressure in the cartridge which is an effective method for keeping out contaminants. Oil mist systems are especially effective for high speeds.

If oil lubrication is required a modified cartridge is required. Please contact our technical department with details of lubrication system to be used.

Selection of Base Oil Viscosity (ISO-VG)

Grease selected for bearing lubrication must have a base oil of sufficiently high viscosity to adequately separate the rolling elements and race parts under operating conditions, in order for the bearing to provide a long service life. The same comment applies for the viscosity of the oil if oil lubrication is used.

The charts opposite show the recommended operating ranges for three common oil viscosities, for bearings under normal loading (for radial loads up to Cr/10).

In order to use these charts, the 'geometry factor' for the bearing in question must be found, from the table opposite and on the following pages, and this geometry factor multiplied by the bearing speed (in thousands of rpm) in order to obtain the 'velocity factor'.

For example, if an 01E B 65M bearing is to be run at 1800rpm:

The geometry factor is 48.2 from the table.
Velocity factor = $48.2 \times 1800/1000 = 86.76$

To determine the suitability of one of these oils, draw a vertical line from the horizontal axis at the calculated velocity factor, and draw a horizontal line from vertical axis at the operating temperature.

If the lines intersect in the shaded area the viscosity of the oil is suitable.

If the lines intersect above the shaded area a higher viscosity oil is required.

If the lines intersect below the shaded area the bearing may operate satisfactorily, but it is suggested that a lower viscosity oil is used.

The use of these charts is subject to the operating conditions being within the recommended ranges for the lubricant as specified by the lubricant manufacturer.

For conditions not covered by these charts, please contact our technical department.

Note that the lubricant film thickness is not particularly sensitive to load, so for heavier loading the lubricant selection as provided by these charts is usually sufficient provided that the lines drawn on the chart, as explained above, do not intersect at the upper edge of the shaded area.

It is recommended that our technical department is contacted with details of the application if extremes of load, speed or temperature are expected.

Shaft Diameter d	Bearing Reference	Geometry factor
35	01 B 35M	27.3
40	01 B 40M	27.3
45	01E B 45M	37.6
50	01E B 50M	37.6
	02 B 50M	39.0
55	01E B 55M	48.2
60	01E B 60M	48.2
	02 B 60M	53.2
65	01E B 65M	48.2
	02 B 65M	53.2
70	01E B 70M	61.4
	02 B 70M	67.1
75	100 B 75M	57.5
	01E B 75M	61.4
	02 B 75M	67.1
80	01E B 80M	77.2
	02 B 80M	83.7
85	100 B 85M	71.5
	01E B 85M	77.2
	02 B 85M	83.7
90	01E B 90M	77.2
	02 B 90M	83.7
95	01E B 95M	92.8
100	100 B 100M	87.9
	01E B 100M	92.8
	02 B 100M	101
	03 B 100M	112
105	01E B 105M	92.8
	02 B 105M	101

Shaft Diameter d	Bearing Reference	Geometry factor
110	100 B 110M	104
	01 B 110M	112
	02 B 110M	120
115	03 B 110M	127
	01 B 115M	112
120	02 B 115M	120
	100 B 120M	124
125	01 B 120M	129
	02 B 120M	139
	03 B 120M	127
130	01 B 125M	129
	02 B 125M	139
135	100 B 130M	124
	01 B 130M	129
	02 B 130M	139
	03 B 130M	143
140	01 B 135M	147
145	100 B 140M	141
	01 B 140M	147
	02 B 140M	158
150	03 B 140M	160
	02 B 145M	158
	100 B 150M	155
155	01 B 150M	164
	02 B 150M	176
	03 B 150M	181
160	01 B 155M	164
	02 B 155M	176

Shaft Diameter d	Bearing Reference	Geometry factor
160	01 B 600-160M	164
	01 B 160M	183
	02 B 600-160M	176
	02 B 160M	198
	03 B 160M	212
170	01 B 608-170M	183
	01 B 170M	200
	02 B 170M	198
	03 B 170M	212
175	01 B 175M	200
	02 B 175M	216
180	01 B 180M	200
	02 B 180M	216
	03 B 180M	232
190	01 B 190M	237
	02 B 190M	258
	03 B 190M	277
200	01 B 200M	237
	02 B 200M	258
	03 B 200M	277
220	01 B 220M	277
	02 B 220M	297
	03 B 220M	328
230	01 B 230M	277
	02 B 230M	297

Shaft Diameter d	Bearing Reference	Geometry factor
240	01 B 240M	323
	02 B 240M	343
	03 B 240M	359
250	01 B 250M	323
	02 B 250M	343
	03 B 250M	359
260	01 B 1000-260M	323
	01 B 260M	364
	02 B 260M	343
	03 B 260M	359
270	01 B 270M	364
275	01 B 275M	364
280	01 B 280M	364
	02 B 280M	386
	03X B 280M	413
	03E B 280M	397
290	01 B 290M	413
	03 B 290M	463
300	01 B 300M	413
	02 B 300M	435
	03 B 300M	463
320	01 B 320M	455
	02 B 320M	484
	03 B 320M	527
330	01 B 330M	455
	02 B 330M	484

Shaft Diameter d	Bearing Reference	Geometry factor
340	01 B 1300-340M	455
	01 B 340M	501
	02 B 340M	536
	03E B 340M	551
350	01 B 350M	501
	02 B 350M	536
360	01 B 1400-360M	501
	01 B 360M	551
	02 B 360M	536
	03E B 360M	551
	03X B 360M	576
380	01 B 380M	551
	02 B 380M	579
	03 B 380M	631
390	01 B 390M	600
400	01 B 400M	600
	02 B 400M	631
	03 B 400M	631
420	01 B 420M	650
	02 B 420M	685
	03E B 420M	701
440	01 B 440M	701
	02 B 440M	730
	03E B 440M	701

Shaft Diameter d	Bearing Reference	Geometry factor
460	01 B 460M	701
	02 B 460M	730
	03E B 460M	759
	03X B 460M	807
480	01 B 480M	757
	02 B 480M	790
	03X B 480M	807
500	01 B 500M	810
	02 B 500M	837
	03 B 500M	917
530	01 B 530M	879
	02 B 530M	903
	03 B 530M	917
560	01 B 560M	934
	02 B 560M	966
	03E B 560M	995
580	01 B 580M	995
	02 B 580M	1031
600	01 B 600M	1053
	02 B 600M	1075
	03E B 600M	1053

Cooper Bearing recommended speed and temperature range for VG 150 grease and oils

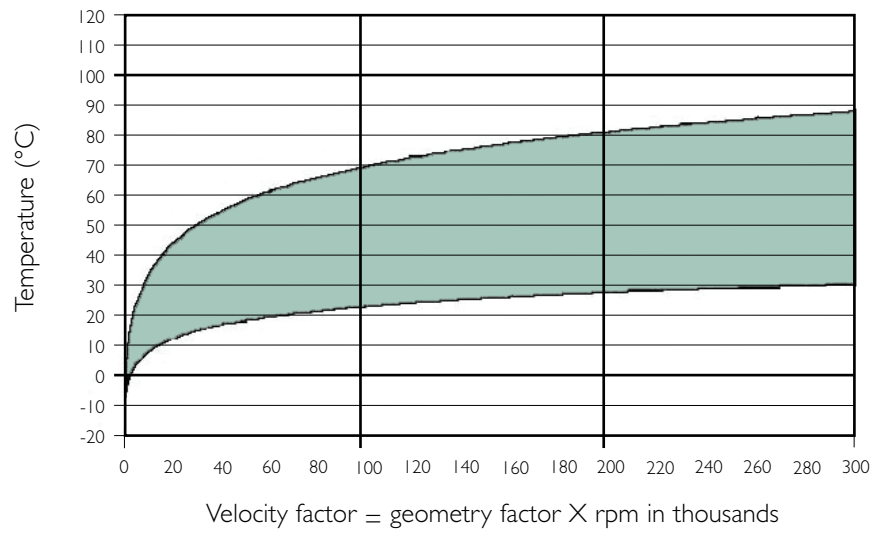

Cooper Bearing recommended speed and temperature range for VG 220 grease and oils

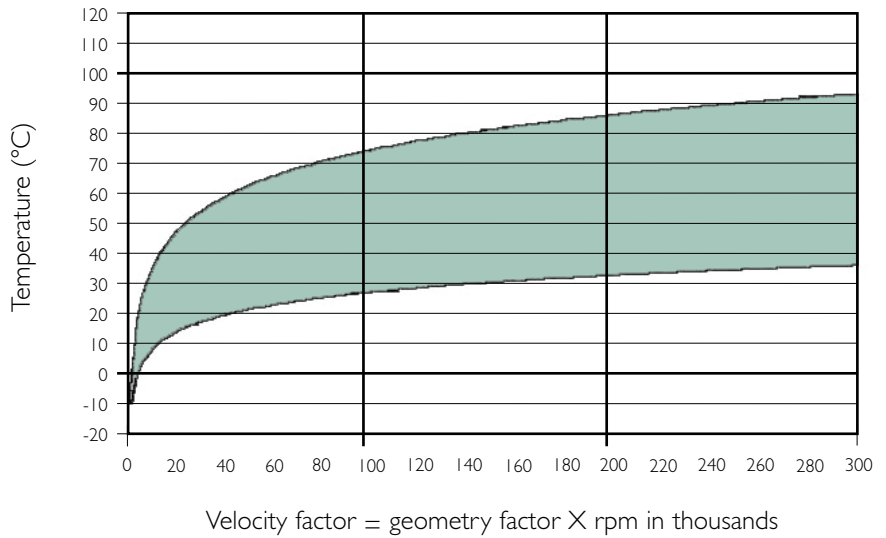

Cooper Bearing recommended speed and temperature range for VG 460 grease and oils

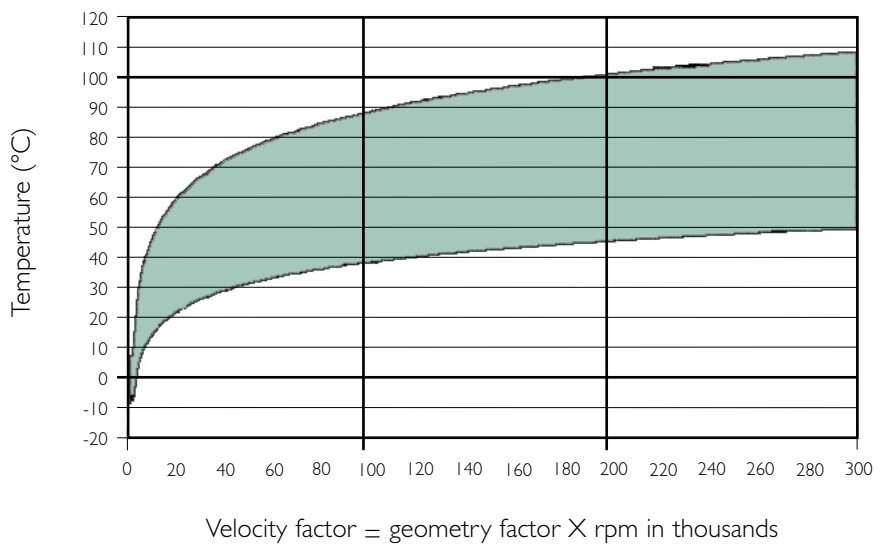

Bearings

The following pages list standard bearings of series 100, 01, 02 and 03, alongside compatible standard cartridges and pedestals. Principles of bearing selection are explained on pages 11 to 13.

Large bore bearings and 04 Series bearings are listed separately elsewhere in this catalogue.

Cartridges and Seals

Most Cooper split roller bearings are mounted in a 'cartridge'. This is a spherically-machined inner housing that can be fitted into a number of outer housings including pedestals, flanges, rod-ends, take-up units and custom housings either supplied by Cooper or manufactured by the customer.

The cartridge houses the bearing and seals. For any given size of bearing there are two main types of cartridge. Except for in North America the standard cartridge, up to 300mm / 12" shaft size, features a groove in each end bore that can accommodate felt seals (supplied as standard with the cartridge), high temperature packing, or a rubber lip seal. Above 300mm / 12" shaft size the standard cartridge features grease groove seals.

The standard cartridge in North America, but available worldwide, is the 'triple labyrinth' (TL) type, which accommodates either an aluminium triple labyrinth (ATL) seal or, on some sizes only, a neoprene triple labyrinth (NTL). ATL and NTL seals are not supplied with the cartridge and must be ordered separately.

Cartridges to accommodate other types of seal, such as lip seals for submerged conditions, and combinations of seals, may require special machining. They may also have a different length on shaft to the standard types listed.

Cartridges for expansion (EX) and fixed (GR) bearings differ, so care must be taken to order the correct version and ensure that EX and GR bearings are fitted in the correct cartridges during assembly.

Cartridges for GR bearings feature drillings for 'side screws' that locate the outer race against one side of the seating, while cartridges for EX bearings may include additional internal machining.

Pedestals

Pedestals (also known as Pillow Blocks) are the most common method of mounting Cooper split roller bearings (in cartridges as explained above).

Cooper standard pedestals are shown on the following pages. Pedestals with height-to-centre and bolt hole configurations to match industry standard SN, SD and SAF pillow blocks are listed separately in this catalogue.

Pedestals are common between expansion (EX) and fixed (GR) units.

Loads and Mounting

The maximum safe radial load for a pedestal is based on the static rating (C_{or}) of the corresponding size of roller bearing. The full static rating can be applied if the angle of the load falls within the shaded area of the sketch.

If the radial load falls outside the shaded area, if the radial load exceeds C_{or} , or if the axial loads exceed 50% of the axial rating (C_a) of the corresponding roller bearing please consult our technical department. For 100 Series bearings, the maximum axial load is reduced to 35% C_a .

Pedestals should be fully supported on a flat, rigid surface to avoid distortion of the pedestal or deflection under load.

For loads within 45° of the horizontal, the base should be chocked or dowed.

Standard Cooper pedestals are manufactured from grey iron. Ductile iron and steel pedestals are also available and should be considered for shock or pulsating loads. Particulars of pedestals in alternative materials are available from our technical department.

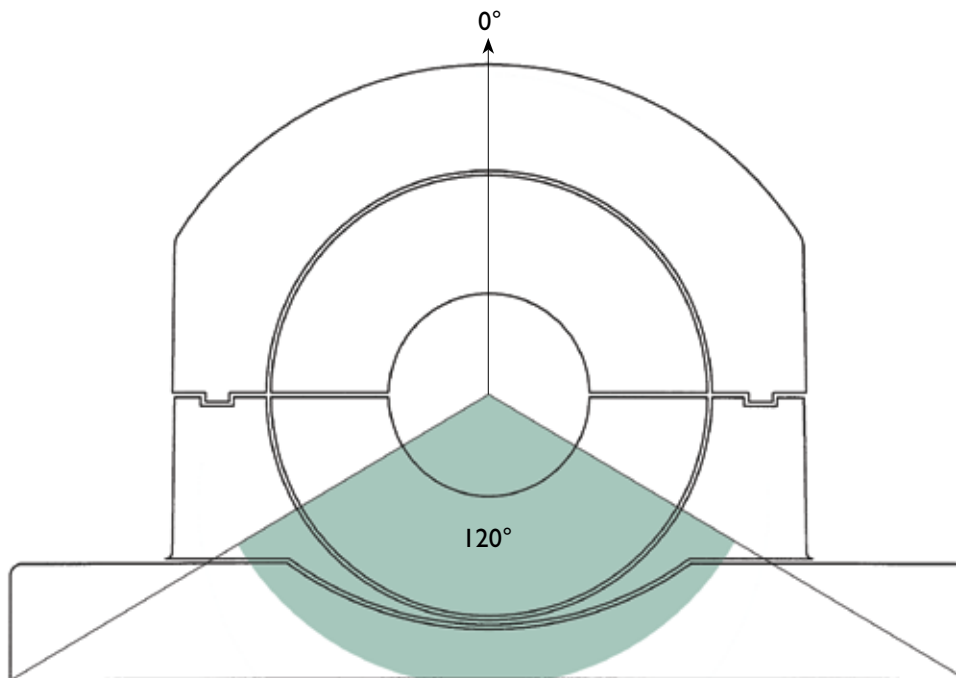

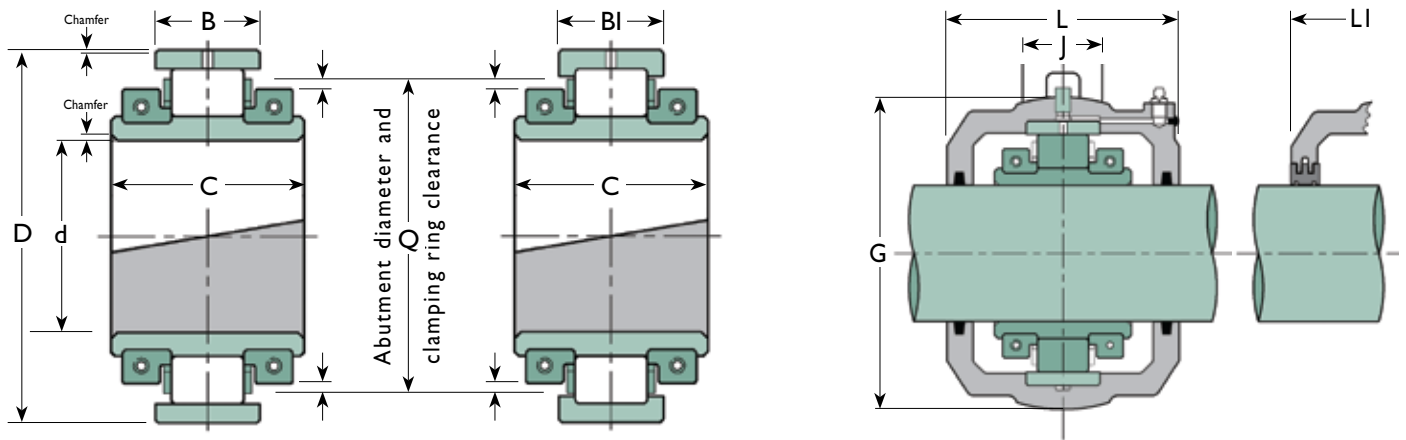

ROLLER BEARING

Shaft Diameter d (mm)	Reference (1)	Bearing Ratings				Principal Dimensions					Axial Movement (2)		Mass (kg)
		Cr (kN)	Cor (kN)	Ca (kN)	Max. Speed (rpm)	D (mm)	C (mm)	B (mm)	BI (mm)	Q (mm)	Usual (mm)	Max. (mm)	
35	01 B 35M	67	67	3.2	5400	84.14	50.1	23.8	23.8	75	3.5	5.5	1.2
40	01 B 40M	67	67	3.2	5400	84.14	50.1	23.8	23.8	75	3.5	5.5	1.2
45	01E B 45M	95	105	3.8	4630	98.42	55.7	25.4	25.4	90	4	5	1.5
50	01E B 50M	95	105	3.8	4630	98.42	55.7	25.4	25.4	90	4	5	1.5
	02 B 50M	119	125	6.2	4350	107.95	67.5	35.0	35.0	98	5	10.5	2.0
55	01E B 55M	135	157	7.2	3940	114.30	55.7	27.0	27.0	105	4.5	4.5	1.8
60	01E B 60M	135	157	7.2	3940	114.30	55.7	27.0	27.0	105	4.5	4.5	1.8
	02 B 60M	168	193	8.8	3680	127.00	72.3	38.9	38.9	116	5.5	11	3.0
65	01E B 65M	135	157	7.2	3940	114.30	55.7	27.0	27.0	105	4.5	4.5	1.8
	02 B 65M	168	193	8.8	3680	127.00	72.3	38.9	38.9	116	5.5	11	3.0
70	01E B 70M	166	197	10.8	3310	133.35	61.2	31.8	31.8	124	5	7	2.5
	02 B 70M	229	268	10.6	3080	149.22	82.6	46.1	46.1	138	6	13.5	5.0
75	100 B 75M	91	128	7.0	4125	114.30	48.0	27.0	27.0	102	3.5	7	1.2
	01E B 75M	166	197	10.8	3310	133.35	61.2	31.8	31.8	124	5	7	2.5
	02 B 75M	229	268	10.6	3080	149.22	82.6	46.1	46.1	138	6	13.5	5.0

CARTRIDGE

References (1)		Principal Dimensions				Mass (kg)
Cartridge for Felt seals	Cartridge for ATL seals	G (mm)	J (mm)	L (mm)	LI (mm)	
01 C 35M	01 C 01	100.00	25	86	86	2
01 C 40M	01 C 01	100.00	25	86	86	2
01 C 45M	01 C 02	117.48	25	98	98	2.5
01 C 50M	01 C 02	117.48	25	98	98	2.5
02 C 50M	02 C 03	134.94	32	114	114	4
01 C 55M	01 C 03	134.94	32	104	104	3.2
01 C 60M	01 C 03	134.94	32	104	104	3.2
02 C 60M	02 C 04	157.16	38	126	126	7
01 C 65M	01 C 03	134.94	32	104	104	3.2
02 C 65M	02 C 04	157.16	38	126	126	7
01 C 70M	01 C 04	157.16	38	114	114	5.5
02 C 70M	02 C 05	177.80	50	140	140	9
100 C 75M	100 C 03	134.94	32	104	104	3.6
01 C 75M	01 C 04	157.16	38	114	114	5.5
02 C 75M	02 C 05	177.80	50	140	140	9

(1) Add 'EX' or 'GR' to reference for expansion type or fixed type respectively, e.g.:
 bearing: 01E B 60M EX
 cartridge: 01 C 60M EX or 01 C 03 EX
 Pedestals are common between expansion and fixed type units

(2) Total available axial movement given. Maximum offset from centreline half this amount. 'Usual' axial movement denotes maximum recommended range of running positions of EX bearing for optimum performance. 'Maximum' axial movement denotes available movement before fouling occurs in standard Cooper cartridge.

METRIC BEARINGS, CARTRIDGES AND PEDESTALS TO 75mm BORE SIZE

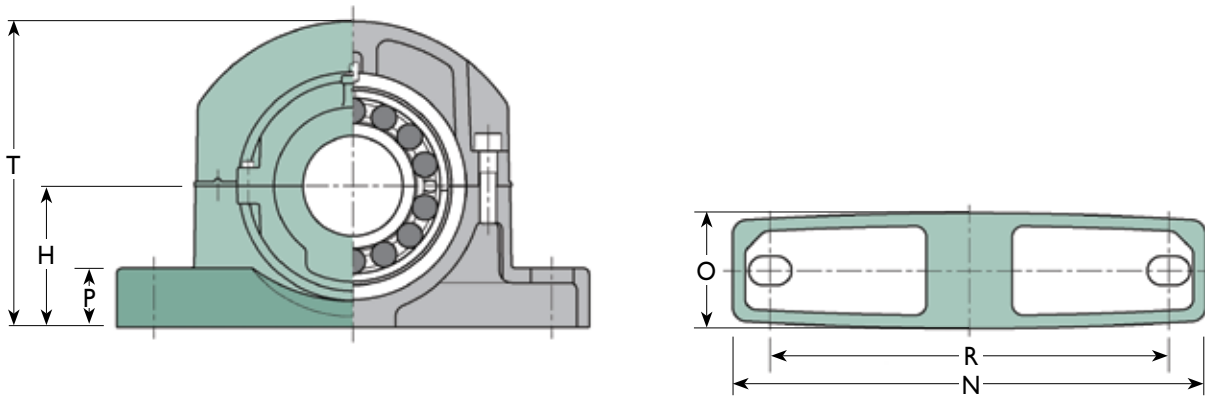

PEDESTAL

Reference	H (mm)	R		Ro (mm)	S (mm)	Bolts			N (mm)	O (mm)	P (mm)	T (mm)	Mass (Kg)	Shaft Diameter d (mm)
		Min. (mm)	Max. (mm)			No.	Metric Size	Inch Size						
P01	60	172	192	-	-	2	M12	1/2"	228	60	22	138	2.5	35
P01	60	172	192	-	-	2	M12	1/2"	228	60	22	138	2.5	40
P02	70	203	227	-	-	2	M16	5/8"	270	60	25	158	3.2	45
P02	70	203	227	-	-	2	M16	5/8"	270	60	25	158	3.2	50
P03	80	226	242	-	-	2	M16	5/8"	280	70	32	180	4.9	
P03	80	226	242	-	-	2	M16	5/8"	280	70	32	180	4.9	55
P03	80	226	242	-	-	2	M16	5/8"	280	70	32	180	4.9	60
P04	95	260	280	-	-	2	M20	3/4"	330	76	38	208	6.9	
P03	80	226	242	-	-	2	M16	5/8"	280	70	32	180	4.9	65
P04	95	260	280	-	-	2	M20	3/4"	330	76	38	208	6.9	
P04	95	260	280	-	-	2	M20	3/4"	330	76	38	208	6.9	70
P05	112	312	328	-	-	2	M24	7/8"	380	90	44	252	13.3	
P03	80	226	242	-	-	2	M16	5/8"	280	70	32	180	4.9	75
P04	95	260	280	-	-	2	M20	3/4"	330	76	38	208	6.9	
P05	112	312	328	-	-	2	M24	7/8"	380	90	44	252	13.3	

- (3) Maximum fillet radii of abutments:
inner race: 1.2mm
outer race: 0.4mm

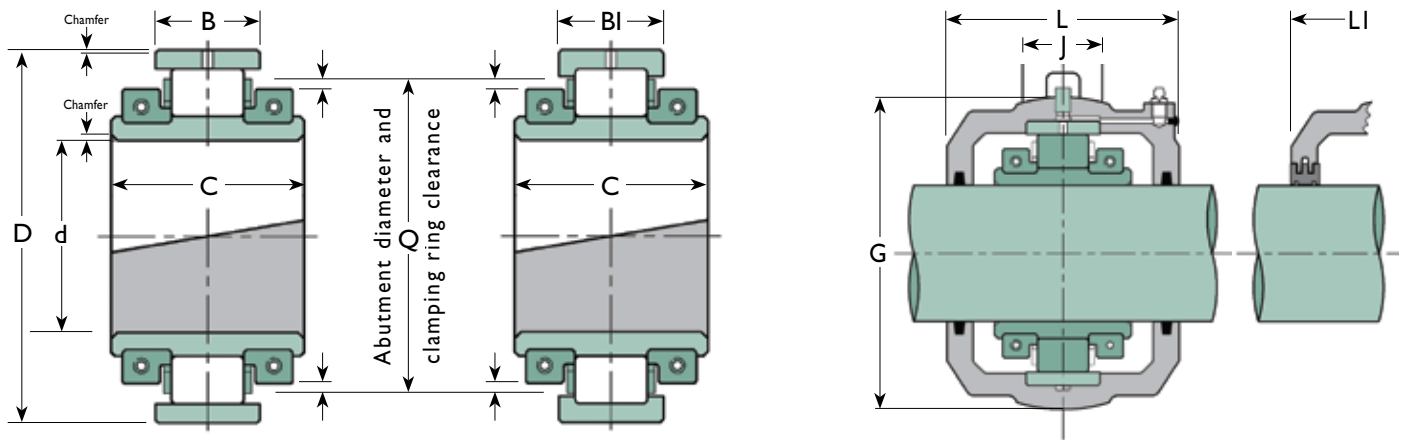

ROLLER BEARING

Shaft Diameter d (mm)	Reference (1)	Bearing Ratings				Principal Dimensions					Axial Movement (2)		Mass (kg)
		Cr (kN)	Cor (kN)	Ca (kN)	Max. Speed (rpm)	D (mm)	C (mm)	B (mm)	BI (mm)	Q (mm)	Usual (mm)	Max. (mm)	
80	01E B 80M	234	299	13.6	2790	152.40	70.7	38.9	38.9	142	6	10	4.0
	02 B 80M	280	345	17.8	2520	169.86	89.7	48.4	48.4	156	7	14	7.0
85	100 B 85M	142	209	12.3	3600	133.35	60.0	31.8	31.8	120	5	6	2.1
	01E B 85M	234	299	13.6	2790	152.40	70.7	38.9	38.9	142	6	10	4.0
	02 B 85M	280	345	17.8	2520	169.86	89.7	48.4	48.4	156	7	14	7.0
90	01E B 90M	234	299	13.6	2790	152.40	70.7	38.9	38.9	142	6	10	4.0
	02 B 90M	280	345	17.8	2520	169.86	89.7	48.4	48.4	156	7	14	7.0
95	01E B 95M	320	421	19.6	2340	174.62	81.0	45.3	45.3	162	7	10.5	6.0
100	100 B 100M	191	288	18.3	3090	152.40	65.0	38.9	38.9	140	6	9.0	2.8
	01E B 100M	320	421	19.6	2340	174.62	81.0	45.3	45.3	162	7	10.5	6.0
	02 B 100M	362	456	25.0	2130	193.68	92.1	51.6	51.6	178	8	13.5	9.0
	03 B 100M	610	684	31.2	1820	254.00	136.0	84.2	84.2	219	11	29	30
105	01E B 105M	320	421	19.6	2340	174.62	81.0	45.3	45.3	162	7	10.5	6.0
	02 B 105M	362	456	25.0	2130	193.68	92.1	51.6	51.6	178	8	13.5	9.0

CARTRIDGE

References (1)		Principal Dimensions				Mass (kg)
Cartridge for Felt seals	Cartridge for ATL seals	G (mm)	J (mm)	L (mm)	LI (mm)	
01 C 80M	01 C 05	177.80	50	136	136	7
02 C 80M	02 C 06	203.20	50	154	154	10
100 B 85M	100 C 04	157.16	38	114	114	5.4
01 C 85M	01 C 05	177.80	50	136	136	7
02 C 85M	02 C 06	203.20	50	154	154	10
01 C 90M	01 C 05	177.80	50	136	136	7
02 C 90M	02 C 06	203.20	50	154	154	10
01 C 95M	01 C 06	203.20	50	134	134	8
100 C 100M	100 C 05	177.80	50	136	136	7.4
01 C 100M	01 C 06	203.20	50	134	134	8
02 C 100M	02 C 07	231.78	64	146	146	12
03 C 100M	03 C 54	308.00	95	200	206	41
01 C 105M	01 C 06	203.20	50	134	134	8
02 C 105M	02 C 07	231.78	64	146	146	12

(1) Add 'EX' or 'GR' to reference for expansion type or fixed type respectively, e.g.:
 bearing: 01E B 90M EX
 cartridge: 01 C 90M EX or 01 C 05 EX
 Pedestals are common between expansion and fixed type units

(2) Total available axial movement given. Maximum offset from centreline half this amount. 'Usual' axial movement denotes maximum recommended range of running positions of EX bearing for optimum performance. 'Maximum' axial movement denotes available movement before fouling occurs in standard Cooper cartridge.

METRIC BEARINGS, CARTRIDGES AND PEDESTALS FROM 80mm TO 105mm BORE SIZE

2 Bolt

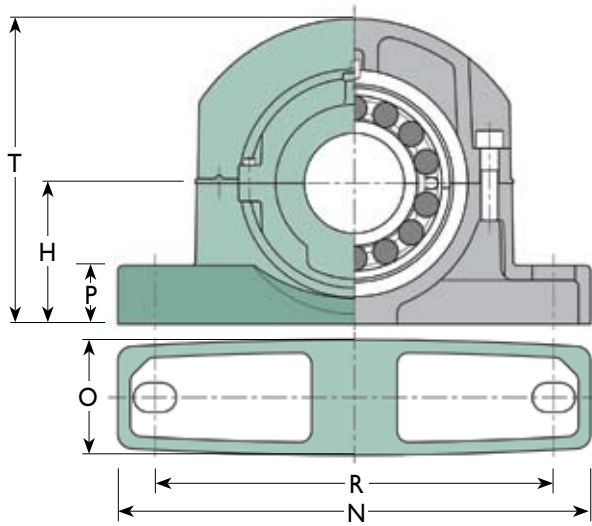

4 Bolt

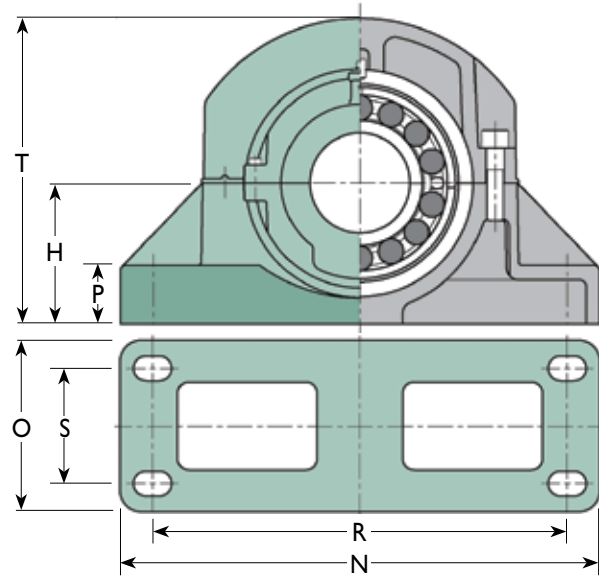

PEDESTAL

Reference	H (mm)	R		Ro (mm)	S (mm)	Bolts			N (mm)	O (mm)	P (mm)	T (mm)	Mass (Kg)	Shaft Diameter d (mm)
		Min. (mm)	Max. (mm)			No.	Metric Size	Inch Size						
P05	112	312	328	-	-	2	M24	7/8"	380	90	44	252	13.3	80
P06	125	342	366	-	-	2	M24	7/8"	420	102	52	272	14.7	
P04	95	260	280	-	-	2	M20	3/4"	330	76	38	208	6.9	85
P05	112	312	328	-	-	2	M24	7/8"	380	90	44	252	13.3	
P06	125	342	366	-	-	2	M24	7/8"	420	102	52	272	14.7	
P05	112	312	328	-	-	2	M24	7/8"	380	90	44	252	13.3	90
P06	125	342	366	-	-	2	M24	7/8"	420	102	52	272	14.7	
P06	125	342	366	-	-	2	M24	7/8"	420	102	52	272	14.7	95
P05	112	312	328	-	-	2	M24	7/8"	380	90	44	252	13.3	100
P06	125	342	366	-	-	2	M24	7/8"	420	102	52	272	14.7	
P07	143	374	410	-	-	2	M24	7/8"	466	120	60	314	20.6	
P54	191	426	450	-	82	4	M24	7/8"	514	152	38	405	61	
P06	125	342	366	-	-	2	M24	7/8"	420	102	52	272	14.7	105
P07	143	374	410	-	-	2	M24	7/8"	466	120	60	314	20.6	

- (3) Maximum fillet radii of abutments:
- inner race: up to and including 90mm shaft size: 1.2mm
over 90mm shaft size: 2mm
 - outer race: 01E and 02 Series up to and including 90mm shaft size, 100 Series: 0.4mm
01E and 02 Series over 90mm shaft size: 0.8mm
03 Series: 2mm

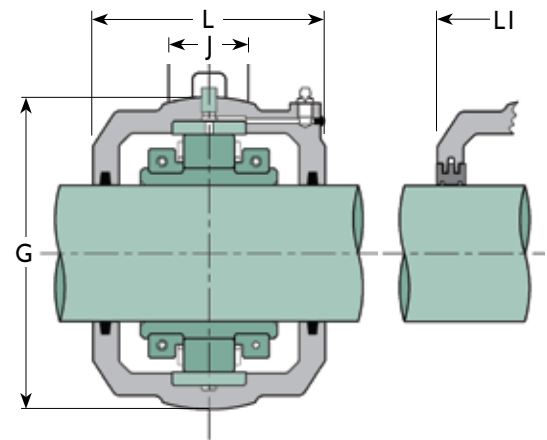
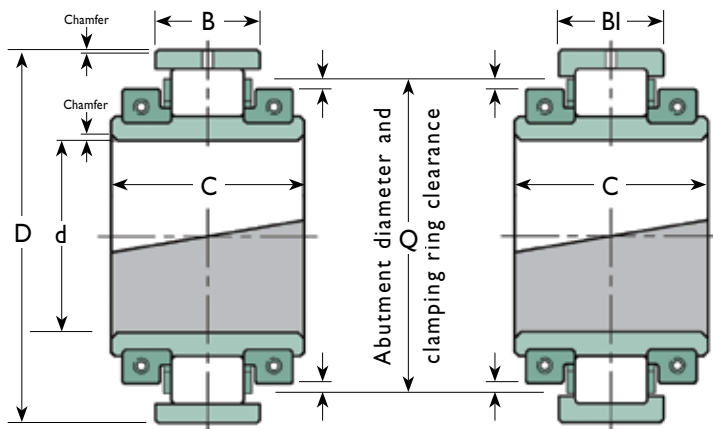

ROLLER BEARING

Shaft Diameter d (mm)	Reference (1)	Bearing Ratings				Principal Dimensions					Axial Movement (2)		Mass (kg)
		Cr (kN)	Cor (kN)	Ca (kN)	Max. Speed (rpm)	D (mm)	C (mm)	B (mm)	BI (mm)	Q (mm)	Usual (mm)	Max. (mm)	
110	100 B 110M	279	426	22.2	2750	174.62	80.0	45.3	45.3	160	7	9.5	4.6
	01 B 110M	306	407	18.6	1970	203.20	84.9	46.9	46.9	182	7	12.5	10.2
	02 B 110M	454	583	31.2	1820	228.60	100.0	57.2	57.2	202	9	13.5	16.0
	03 B 110M	614	698	39.2	1640	266.70	147.0	87.3	87.3	232	11	30	36.0
115	01 B 115M	306	407	18.6	1970	203.20	84.9	46.9	46.9	182	7	12.5	10.2
	02 B 115M	454	583	31.2	1820	228.60	100.0	57.2	57.2	202	9	13.5	16.0
120	100 B 120M	280	433	23.8	2480	203.20	85.0	46.9	46.9	180	7	11	7.4
	01 B 120M	355	484	22.2	1740	222.25	89.7	54.0	54.0	200	7	15	12.8
	02 B 120M	547	713	38.2	1600	254.00	114.3	63.5	63.5	224	10	15	20.0
	03 B 120M	614	698	39.2	1640	266.70	147.0	87.3	87.3	232	11	30	36.0
125	01 B 125M	355	484	22.2	1740	222.25	89.7	54.0	54.0	200	7	15	12.8
	02 B 125M	547	713	38.2	1600	254.00	114.3	63.5	63.5	224	10	15	20.0
130	100 B 130M	280	433	23.8	2480	203.20	85.0	46.9	46.9	180	7	11	7.4
	01 B 130M	355	484	22.2	1740	222.25	89.7	54.0	54.0	200	7	15	12.8
	02 B 130M	547	713	38.2	1600	254.00	114.3	63.5	63.5	224	10	15	20.0
	03 B 130M	706	852	49.0	1500	279.40	140.0	73.1	84.2	245	11	18	36.0

CARTRIDGE

References (1)		Principal Dimensions				Mass (kg)
Cartridge for Felt seals	Cartridge for ATL seals	G (mm)	J (mm)	L (mm)	LI (mm)	
100 C 110M	100 C 06	203.20	50	134	134	7.9
01 C 110M	01 C 07	231.78	64	142	142	11.9
02 C 110M	02 C 08	266.70	76	162	162	19
03 C 110M	03 C 55	323.85	102	210	222	46
01 C 115M	01 C 07	231.78	64	142	142	11.9
02 C 115M	02 C 08	266.70	76	162	162	19
100 C 120M	100 C 07	231.78	64	142	142	11
01 C 120M	01 C 08	266.70	76	156	156	19.5
02 C 120M	02 C 10	295.28	82	184	184	26
03 C 120M	03 C 55	323.85	102	210	222	46
01 C 125M	01 C 08	266.70	76	156	156	19.5
02 C 125M	02 C 10	295.28	82	184	184	26
100 C 130M	100 C 07	231.78	64	142	142	11
01 C 130M	01 C 08	266.70	76	156	156	19.5
02 C 130M	02 C 10	295.28	82	184	184	26
03 C 130M	03 C 56	323.85	102	214	222	48

(1) Add 'EX' or 'GR' to reference for expansion type or fixed type respectively, e.g.:
 bearing: 01 B 120M EX
 cartridge: 01 C 120M EX or 01 C 08 EX
 Pedestals are common between expansion and fixed type units

(2) Total available axial movement given. Maximum offset from centreline half this amount. 'Usual' axial movement denotes maximum recommended range of running positions of EX bearing for optimum performance. 'Maximum' axial movement denotes available movement before fouling occurs in standard Cooper cartridge.

METRIC BEARINGS, CARTRIDGES AND PEDESTALS FROM 110mm TO 130mm BORE SIZE

2 Bolt

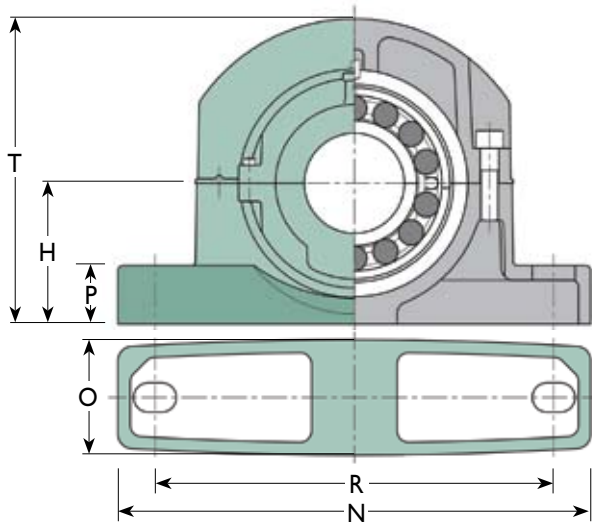

4 Bolt

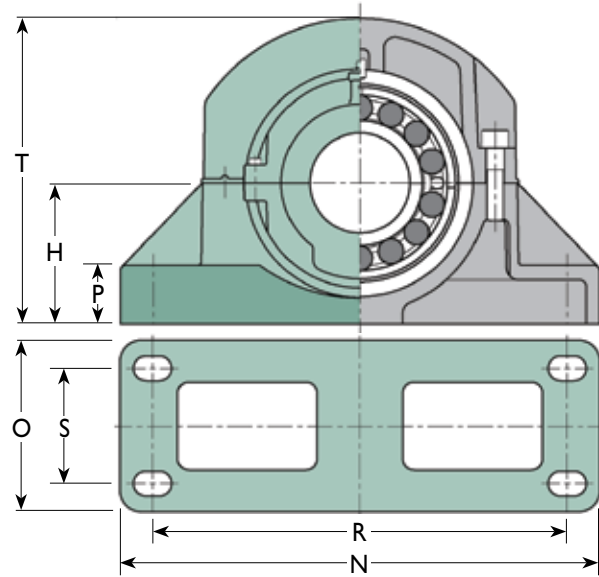

PEDESTAL

Reference	H (mm)	R		Ro (mm)	S (mm)	Bolts		N (mm)	O (mm)	P (mm)	T (mm)	Mass (Kg)	Shaft Diameter d (mm)	
		Min. (mm)	Max. (mm)			No.	Metric Size							Inch Size
P06	125	342	366	-	-	2	M24	7/8"	420	102	52	272	14.7	110
P07	143	374	410	-	-	2	M24	7/8"	466	120	60	314	20.6	
P08	162	438	462	-	120	4	M24	7/8"	508	178	38	372	43.3	
P55	197	446	470	-	88	4	M24	1"	534	166	38	425	69	
P07	143	374	410	-	-	2	M24	7/8"	466	120	60	314	20.6	115
P08	162	438	462	-	120	4	M24	7/8"	508	178	38	372	43.3	
P07	143	374	410	-	-	2	M24	7/8"	466	120	60	314	20.6	120
P08	162	438	462	-	120	4	M24	7/8"	508	178	38	372	43.3	
P10	181	484	508	-	120	4	M24	7/8"	558	178	41	415	54	
P55	197	446	470	-	88	4	M24	1"	534	166	38	425	69	
P08	162	438	462	-	120	4	M24	7/8"	508	178	38	372	43.3	125
P10	181	484	508	-	120	4	M24	7/8"	558	178	41	415	54	
P07	143	374	410	-	-	2	M24	7/8"	466	120	60	314	20.6	130
P08	162	438	462	-	120	4	M24	7/8"	508	178	38	372	43.3	
P10	181	484	508	-	120	4	M24	7/8"	558	178	41	415	54	
P56	203	458	482	-	96	4	M24	1"	546	166	48	435	74	

- (3) Maximum fillet radii of abutments:
 inner race: 2mm
 outer race: 100, 01 and 02 Series: 0.8mm
 03 Series: 2mm

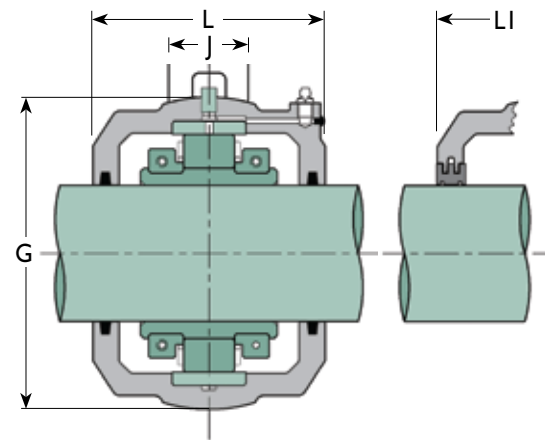
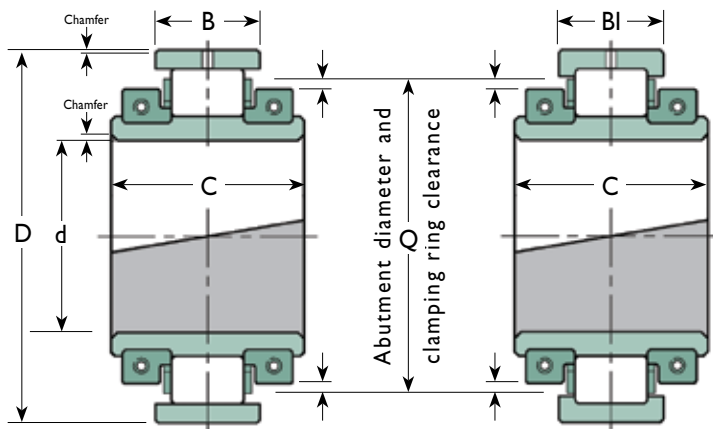

ROLLER BEARING

Shaft Diameter d (mm)	Reference (1)	Bearing Ratings				Principal Dimensions					Axial Movement (2)		
		Cr (kN)	Cor (kN)	Ca (kN)	Max. Speed (rpm)	D (mm)	C (mm)	B (mm)	BI (mm)	Q (mm)	Usual (mm)	Max. (mm)	Mass (kg)
135	01 B 135M	394	542	25.8	1570	241.30	98.4	55.6	55.6	216	8	16	15.0
	02 B 135M	608	808	45.4	1450	273.05	117.5	66.7	66.7	240	10	15	24.0
140	100 B 140M	331	520	30.5	2250	222.25	90.0	54.0	54.0	195	7	13	9.3
	01 B 140M	394	542	25.8	1570	241.30	98.4	55.6	55.6	216	8	16	15.0
	02 B 140M	608	808	45.4	1450	273.05	117.5	66.7	66.7	240	10	15	24.0
	03 B 140M	886	1069	58.8	1340	304.80	147.0	79.4	90.5	270	12	18	44.0
145	02 B 145M	608	808	45.4	1450	273.05	117.5	66.7	66.7	240	10	15	24.0
150	100 B 150M	397	606	31.4	2060	241.30	90.0	55.6	55.6	215	8	15.5	10.4
	01 B 150M	428	616	29.4	1450	254.00	98.4	55.6	55.6	230	8	16	16.6
	02 B 150M	724	1005	52.4	1320	292.10	123.8	68.3	68.3	258	10	15	29.0
	03 B 150M	994	1213	69.4	1220	330.20	160.0	81.0	96.9	292	13	16	57.0
155	01 B 155M	428	616	29.4	1450	254.00	98.4	55.6	55.6	230	8	16	16.6
	02 B 155M	724	1005	52.4	1320	292.10	123.8	68.3	68.3	258	10	15	29.0

CARTRIDGE

References (1)		Principal Dimensions				Mass (kg)
Cartridge for Felt seals	Cartridge for ATL seals	G (mm)	J (mm)	L (mm)	LI (mm)	
01 C 135M	01 C 09	279.40	76	168	168	20.8
02 C 135M	02 C 30	323.85	90	188	188	33
100 C 140M	100 C 08	266.70	76	156	156	18.4
01 C 140M	01 C 09	279.40	76	168	168	20.8
02 C 140M	02 C 30	323.85	90	188	188	33
03 C 140M	03 C 57	355.60	108	216	230	52
02 C 145M	02 C 30	323.85	90	188	188	33
100 C 150M	100 C 09	279.40	76	168	168	19.4
01 C 150M	01 C 10	295.28	82	174	174	24.4
02 C 150M	02 C 31	336.55	95	204	204	39
03 C 150M	03 C 58	393.70	114	232	254	70
01 C 155M	01 C 10	295.28	82	174	174	24.4
02 C 155M	02 C 31	336.55	95	204	204	39

(1) Add 'EX' or 'GR' to reference for expansion type or fixed type respectively, e.g.:
 bearing: 01 B 150M EX
 cartridge: 01 C 150M EX or 01 C 10 EX
 Pedestals are common between expansion and fixed type units

(2) Total available axial movement given. Maximum offset from centreline half this amount. 'Usual' axial movement denotes maximum recommended range of running positions of EX bearing for optimum performance. 'Maximum' axial movement denotes available movement before fouling occurs in standard Cooper cartridge.

METRIC BEARINGS, CARTRIDGES AND PEDESTALS FROM 135mm TO 155mm BORE SIZE

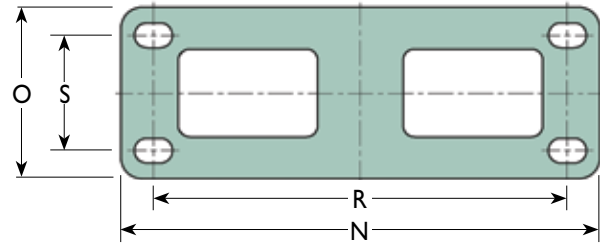
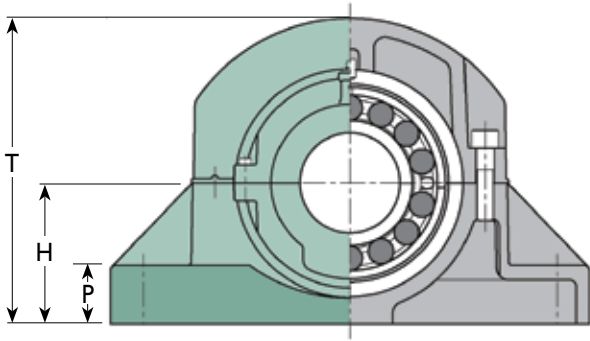

PEDESTAL

Reference	H (mm)	R		Ro (mm)	S (mm)	Bolts		N (mm)	O (mm)	P (mm)	T (mm)	Mass (Kg)	Shaft Diameter d (mm)	
		Min. (mm)	Max. (mm)			No.	Metric Size							Inch Size
P09	181	470	494	-	120	4	M24	7/8"	558	178	41	405	52	135
P30	203	534	558	-	120	4	M24	1"	610	178	51	460	76	
P08	162	438	462	-	120	4	M24	7/8"	508	178	38	372	43.3	140
P09	181	470	494	-	120	4	M24	7/8"	558	178	41	405	52	
P30	203	534	558	-	120	4	M24	1"	610	178	51	460	76	
P57	229	494	534	-	102	4	M30	1 1/4"	622	178	54	485	97	
P30	203	534	558	-	120	4	M24	1"	610	178	51	460	76	145
P09	181	470	494	-	120	4	M24	7/8"	558	178	41	405	52	150
P10	181	484	508	-	120	4	M24	7/8"	558	178	41	415	54	
P31	210	546	570	-	128	4	M24	1"	636	204	50	470	83	
P58	254	538	578	-	120	4	M30	1 1/4"	666	204	57	535	142	
P10	181	484	508	-	120	4	M24	7/8"	558	178	41	415	54	155
P31	210	546	570	-	128	4	M24	1"	636	204	50	470	83	

- (3) Maximum fillet radii of abutments:
 inner race: 2mm
 outer race: 100, 01 and 02 Series: 0.8mm
 03 Series: 2mm

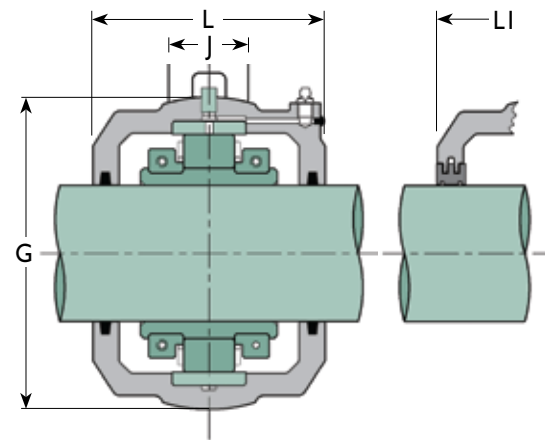
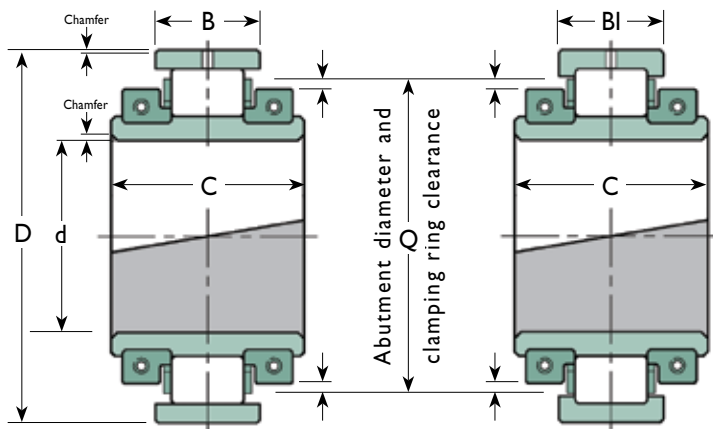

ROLLER BEARING

Shaft Diameter d (mm)	Reference (1)	Bearing Ratings				Principal Dimensions					Axial Movement (2)		Mass (kg)
		Cr (kN)	Cor (kN)	Ca (kN)	Max. Speed (rpm)	D (mm)	C (mm)	B (mm)	BI (mm)	Q (mm)	Usual (mm)	Max. (mm)	
160	01 B 600-160M	428	616	29.4	1450	254.00	98.4	55.6	55.6	230	8	16	16.6
	01 B 160M	487	715	33.0	1320	273.05	109.0	60.3	60.3	248	8	18	21.0
	02 B 600-160M	724	1005	52.4	1320	292.10	123.8	68.3	68.3	258	10	15	29.0
	02 B 160M	762	1033	61.4	1200	317.50	140.0	83.3	83.3	280	11	25	39.0
	03 B 160M	1156	1564	79.2	1110	355.60	171.0	103.2	103.2	308	14	31	72.0
170	01 B 608-170M	487	715	33.0	1320	273.05	109.0	60.3	60.3	248	8	18	21.0
	01 B 170M	524	801	36.4	1220	285.75	109.0	55.5	55.5	260	8	13.5	23.0
	02 B 170M	762	1033	61.4	1200	317.50	140.0	83.3	83.3	280	11	25	39.0
	03 B 170M	1156	1564	79.2	1110	355.60	171.0	103.2	103.2	308	14	31	72.0
175	01 B 175M	524	801	36.4	1220	285.75	109.0	55.5	55.5	260	8	13.5	23.0
	02 B 175M	840	1191	71.2	1120	330.20	140.0	83.3	83.3	294	11	25	45.0
180	01 B 180M	524	801	36.4	1220	285.75	109.0	55.5	55.5	260	8	13.5	23.0
	02 B 180M	840	1191	71.2	1120	330.20	140.0	83.3	83.3	294	11	25	45.0
	03 B 180M	1242	1704	89.0	1030	374.65	178.0	92.1	108.8	326	15	16	79.0
190	01 B 190M	555	893	41.0	1070	311.15	109.0	60.3	60.3	285	8	18	25.0
	02 B 190M	998	1457	80.0	960	368.30	156.0	90.5	90.5	328	13	26	59.0
	03 B 190M	1451	2022	99.6	880	419.10	191.0	97.7	118.3	366	16	16	105

CARTRIDGE

References (1)		Principal Dimensions				Mass (kg)
Cartridge for Felt seals	Cartridge for ATL seals	G (mm)	J (mm)	L (mm)	LI (mm)	
01 C 600-160M	01 C 10 OTL	295.28	82	174	174	24.4
01 C 160M	01 C 11	311.15	76	172	192	30
02 C 600-160M	02 C 31 OTL	336.55	95	204	204	39
02 C 160M	02 C 32	368.30	95	206	232	56
03 C 160M	03 C 59	422.30	120	244	268	81
01 C 608-170M	01 C 11 OTL	311.15	76	172	192	30
01 C 170M	01 C 12	323.85	70	172	200	31
02 C 170M	02 C 32 OTL	368.30	95	206	232	56
03 C 170M	03 C 59	422.30	120	244	268	81
01 C 175M	01 C 12	323.85	70	172	200	31
02 C 175M	02 C 33	381.00	95	222	242	66
01 C 180M	01 C 12	323.85	70	172	200	31
02 C 180M	02 C 33	381.00	95	222	242	66
03 C 180M	03 C 60	431.80	132	254	284	87
01 C 190M	01 C 13	358.78	86	172	200	41
02 C 190M	02 C 34	425.50	105	235	258	84
03 C 190M	03 C 61	489.00	146	270	300	109

(1) Add 'EX' or 'GR' to reference for expansion type or fixed type respectively, e.g.:
 bearing: 01 B 175M EX
 cartridge: 01 C 175M EX or 01 C 12 EX
 Pedestals are common between expansion and fixed type units

(2) Total available axial movement given. Maximum offset from centreline half this amount. 'Usual' axial movement denotes maximum recommended range of running positions of EX bearing for optimum performance. 'Maximum' axial movement denotes available movement before fouling occurs in standard Cooper cartridge.

METRIC BEARINGS, CARTRIDGES AND PEDESTALS FROM 160mm TO 190mm BORE SIZE

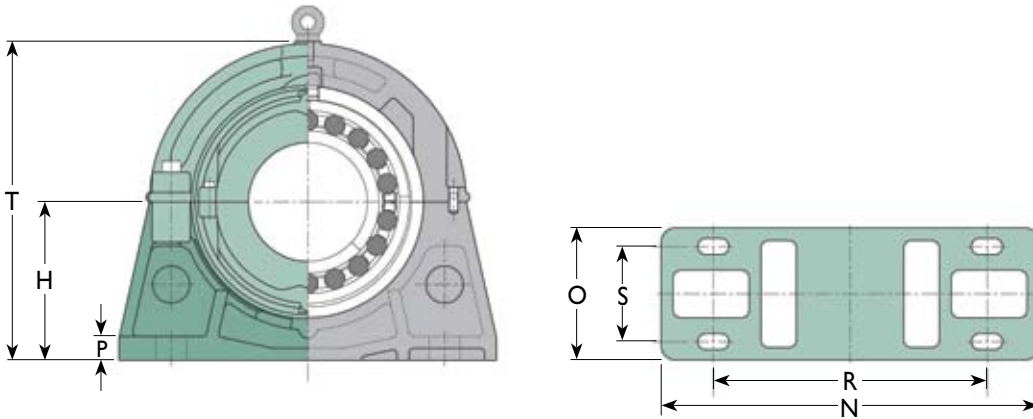

PEDESTAL

Reference	H (mm)	R		Ro (mm)	S (mm)	Bolts		N (mm)	O (mm)	P (mm)	T (mm)	Mass (Kg)	Shaft Diameter d (mm)	
		Min. (mm)	Max. (mm)			No.	Metric Size							Inch Size
P10*	181	484	508	-	120	4	M24	7/8"	558	178	41	415	54	160
P11	213	356	380	-	114	4	M24	1"	508	178	32	430	53	
P31*	210	546	570	-	128	4	M24	1"	636	204	50	470	83	
P32	267	428	468	-	172	4	M30	1 1/4"	596	242	44	535	106	
P59	267	608	648	-	140	4	M30	1 1/4"	736	228	60	570	162	
P11	213	356	380	-	114	4	M24	1"	508	178	32	430	53	170
P12	235	376	400	-	128	4	M24	1"	534	190	35	470	63	
P32	267	428	468	-	172	4	M30	1 1/4"	596	242	44	535	106	
P59	267	608	648	-	140	4	M30	1 1/4"	736	228	60	570	162	
P12	235	376	400	-	128	4	M24	1"	534	190	35	470	63	175
P33	273	438	478	-	166	4	M30	1 1/4"	636	242	44	545	116	
P12	235	376	400	-	128	4	M24	1"	534	190	35	470	63	180
P33	273	438	478	-	166	4	M30	1 1/4"	636	242	44	545	116	
P60	279	616	656	-	152	4	M30	1 1/4"	762	254	64	580	172	
P13	248	410	434	-	140	4	M24	1"	572	204	38	495	83	190
P34	305	488	528	-	190	4	M30	1 1/4"	686	266	50	610	145	
P61	311	616	656	-	172	4	M36	1 1/2"	838	266	67	655	223	

- (3) Maximum fillet radii of abutments:
 inner race: 01B 600-160M: 2mm
 others: 2.3mm
 outer race: 01B 600-160M: 0.8mm
 others: 2mm

* Pedestals marked with an asterisk are of the style illustrated on page 37.

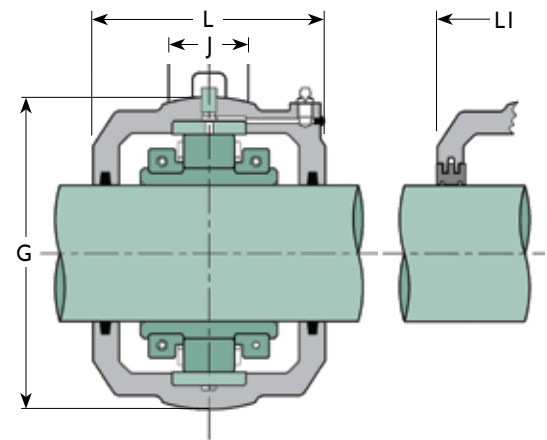
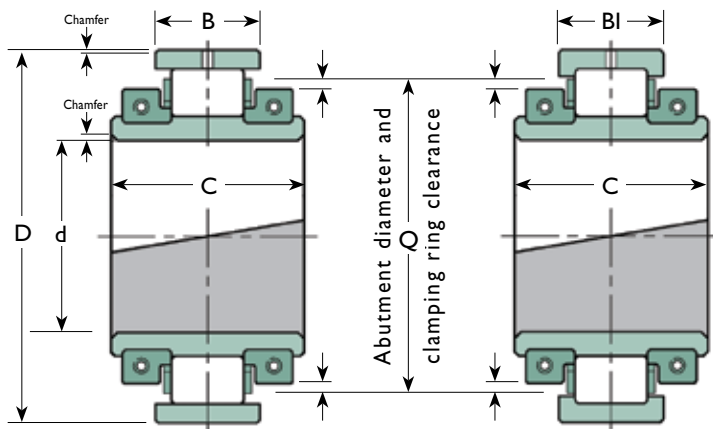

ROLLER BEARING

Shaft Diameter d (mm)	Reference (1)	Bearing Ratings				Principal Dimensions					Axial Movement (2)		Mass (kg)
		Cr (kN)	Cor (kN)	Ca (kN)	Max. Speed (rpm)	D (mm)	C (mm)	B (mm)	BI (mm)	Q (mm)	Usual (mm)	Max. (mm)	
200	01 B 200M	555	893	41.0	1070	311.15	109.0	60.3	60.3	285	8	18	25.0
	02 B 200M	998	1457	80.0	960	368.30	156.0	90.5	90.5	328	13	26	59.0
	03 B 200M	1451	2022	99.6	880	419.10	191.0	97.7	118.3	366	16	16	105
220	01 B 220M	600	980	49.0	930	342.90	115.0	63.5	63.5	315	8	19	32
	02 B 220M	1082	1662	89.8	850	393.70	163.0	90.5	90.5	354	13	26	68
	03 B 220M	1586	2163	109.4	760	469.90	212.0	109.6	131.8	410	18	18	145
230	01 B 230M	600	980	49.0	930	342.90	115.0	63.5	63.5	315	8	19	32
	02 B 230M	1082	1662	89.8	850	393.70	163.0	90.5	90.5	354	13	26	68
240	01 B 240M	675	1182	57.8	820	374.65	122.0	66.7	66.7	344	9	22	40
	02 B 240M	1149	1756	98.8	750	431.80	170.0	96.8	96.8	388	13	29	77
	03 B 240M	1778	2551	131	700	482.60	211.0	105.6	124.6	430	18	33	150
250	01 B 250M	675	1182	57.8	820	374.65	122.0	66.7	66.7	344	9	22	40
	02 B 250M	1149	1756	98.8	750	431.80	170.0	96.8	96.8	388	13	29	77
	03 B 250M	1778	2551	131	700	482.60	211.0	105.6	124.6	430	18	33	150

CARTRIDGE

References (1)		Principal Dimensions				Mass (kg)
Cartridge for Felt seals	Cartridge for ATL seals	G (mm)	J (mm)	L (mm)	LI (mm)	
01 C 200M	01 C 13	358.78	86	172	200	41
02 C 200M	02 C 34	425.50	105	235	258	84
03 C 200M	03 C 61	489.00	146	270	300	109
01 C 220M	01 C 14	387.35	82	178	216	46
02 C 220M	02 C 35	457.20	110	242	274	98
03 C 220M	03 C 62	546.10	165	298	334	155
01 C 230M	01 C 14	387.35	82	178	216	46
02 C 230M	02 C 35	457.20	110	242	274	98
01 C 240M	01 C 15	419.10	90	188	222	58
02 C 240M	02 C 36	495.30	118	248	280	105
03 C 240M	03 C 63	558.80	165	298	334	161
01 C 250M	01 C 15	419.10	90	188	222	58
02 C 250M	02 C 36	495.30	118	248	280	105
03 C 250M	03 C 63	558.80	165	298	334	161

(1) Add 'EX' or 'GR' to reference for expansion type or fixed type respectively, e.g.:
 bearing: 01 B 200M EX
 cartridge: 01 C 200M EX or 01 C 13 EX
 Pedestals are common between expansion and fixed type units

(2) Total available axial movement given. Maximum offset from centreline half this amount. 'Usual' axial movement denotes maximum recommended range of running positions of EX bearing for optimum performance. 'Maximum' axial movement denotes available movement before fouling occurs in standard Cooper cartridge.

METRIC BEARINGS, CARTRIDGES AND PEDESTALS FROM 200mm TO 250mm BORE SIZE

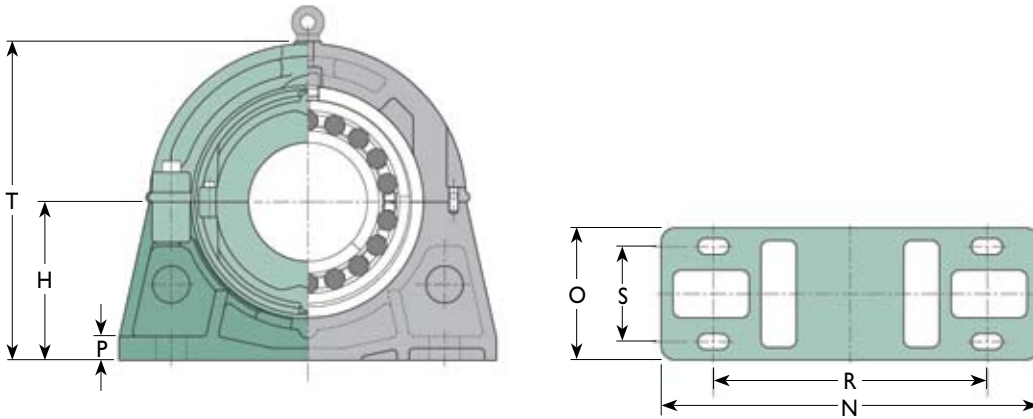

PEDESTAL

Reference	H (mm)	R		Ro (mm)	S (mm)	Bolts			N (mm)	O (mm)	P (mm)	T (mm)	Mass (Kg)	Shaft Diameter d (mm)
		Min. (mm)	Max. (mm)			No.	Metric Size	Inch Size						
P13	248	410	434	-	140	4	M24	1"	572	204	38	495	83	200
P34	305	488	528	-	190	4	M30	1¼"	686	266	50	610	145	
P61	311	616	656	-	172	4	M36	1½"	838	266	67	655	223	
P14	270	440	480	-	140	4	M30	1¼"	636	216	40	540	90	220
P35	324	530	570	-	190	4	M36	1½"	750	280	50	650	179	
P62	349	716	756	-	178	4	M42	1¾"	952	280	76	730	309	
P14	270	440	480	-	140	4	M30	1¼"	636	216	40	540	90	230
P35	324	530	570	-	190	4	M36	1½"	750	280	50	650	179	
P15	292	482	522	-	140	4	M30	1¼"	686	228	44	585	114	240
P36	356	576	616	-	204	4	M36	1½"	812	292	54	710	212	
P63	394	650	690	-	304	4	M42	1¾"	914	406	76	790	392	
P15	292	482	522	-	140	4	M30	1¼"	686	228	44	585	114	250
P36	356	576	616	-	204	4	M36	1½"	812	292	54	710	212	
P63	394	650	690	-	304	4	M42	1¾"	914	406	76	790	392	

- (3) Maximum fillet radii of abutments:
inner race: 2.3mm
outer race: 2mm

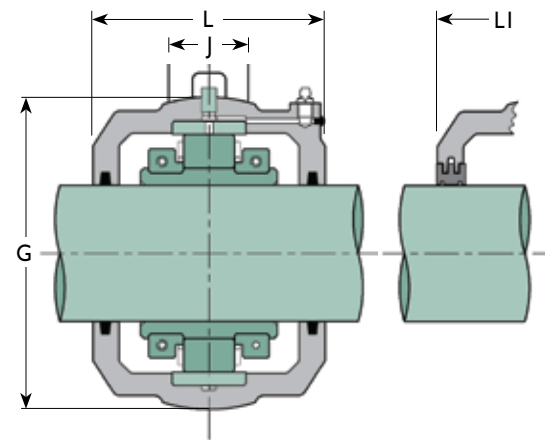
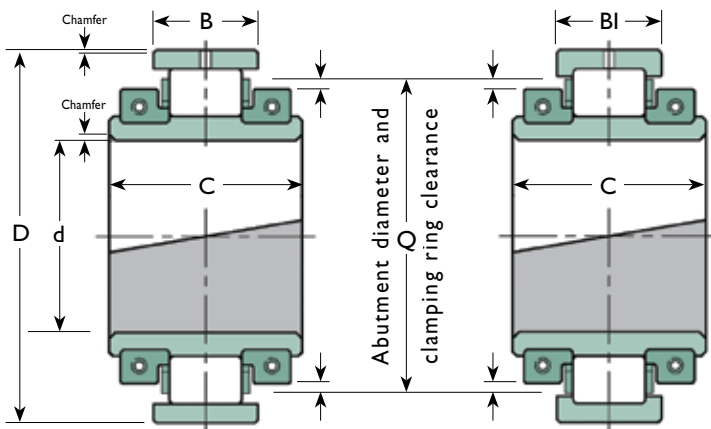

ROLLER BEARING

Shaft Diameter d (mm)	Reference (1)	Bearing Ratings				Principal Dimensions					Axial Movement (2)		Mass (kg)
		Cr (kN)	Cor (kN)	Ca (kN)	Max. Speed (rpm)	D (mm)	C (mm)	B (mm)	BI (mm)	Q (mm)	Usual (mm)	Max. (mm)	
260	01 B 1000-260M	675	1182	57.8	820	374.65	122.0	66.7	66.7	344	9	22	40
	01 B 260M	769	1330	66.8	730	406.40	128.0	69.0	69.0	375	10	20	50
	02 B 260M	1149	1756	98.8	750	431.80	170.0	96.8	96.8	388	13	29	77
	03 B 260M	1778	2551	131	700	482.60	211.0	105.6	124.6	430	18	33	150
270	01 B 270M	769	1330	66.8	730	406.40	128.0	69.0	69.0	375	10	20	50
275	01 B 275M	769	1330	66.8	730	406.40	128.0	69.0	69.0	375	10	20	50
280	01 B 280M	769	1330	66.8	730	406.40	128.0	69.0	69.0	375	10	20	50
	02 B 280M	1367	2145	114	670	463.55	186.0	101.6	101.6	420	14	29	86
	03X B 280M	1956	2960	153	620	520.70	231.0	131.8	131.8	462	18	40	197
	03E B 280M	2105	3233	153	620	495.30	244.0	139.7	139.7	452	20	34	182
290	01 B 290M	806	1452	78.2	650	438.15	143.0	74.6	74.6	404	10	25	60
	03 B 290M	2156	3312	174	560	558.80	244.0	139.7	139.7	496	19	43	238
300	01 B 300M	806	1452	78.2	650	438.15	143.0	74.6	74.6	404	10	25	60
	02 B 300M	1467	2409	129	610	495.30	193.0	103.2	103.2	448	14	30	123
	03 B 300M	2156	3312	174	560	558.80	244.0	139.7	139.7	496	19	43	238

CARTRIDGE

References (1)		Principal Dimensions				Mass (kg)
Cartridge for Felt seals	Cartridge for ATL seals	G (mm)	J (mm)	L (mm)	LI (mm)	
01 C 1000-260M	01 C 15 OTL	419.10	90	188	222	58
01 C 260M	01 C 16	454.00	95	204	232	70
02 C 260M	02 C 36 OTL	495.30	118	248	280	105
03 C 260M	03 C 63	558.80	165	298	334	161
01 C 270M	01 C 16	454.00	95	204	232	70
01 C 275M	01 C 16	454.00	95	204	232	70
01 C 280M	01 C 16	454.00	95	204	232	70
02 C 280M	02 C 37	527.10	130	264	300	131
03X C 280M	03X C 64	596.90	165	324	352	200
03E C 280M	03E C 83	571.50	165	356	356	204
01 C 290M	01 C 17	489.00	98	216	248	86
03 C 290M	03 C 65	641.40	165	346	370	239
01 C 300M	01 C 17	489.00	98	216	248	86
02 C 300M	02 C 38	552.50	128	268	306	129
03 C 300M	03 C 65	641.40	165	346	370	239

(1) Add 'EX' or 'GR' to reference for expansion type or fixed type respectively, e.g.:
 bearing: 01 B 280M EX
 cartridge: 01 C 280M EX or 01 C 16 EX
 Pedestals are common between expansion and fixed type units

(2) Total available axial movement given. Maximum offset from centreline half this amount. 'Usual' axial movement denotes maximum recommended range of running positions of EX bearing for optimum performance. 'Maximum' axial movement denotes available movement before fouling occurs in standard Cooper cartridge.

METRIC BEARINGS, CARTRIDGES AND PEDESTALS FROM 260mm TO 300mm BORE SIZE

4 Bolt

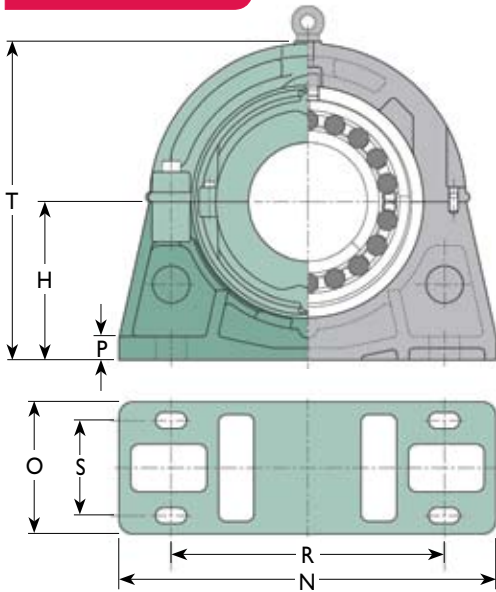

8 Bolt

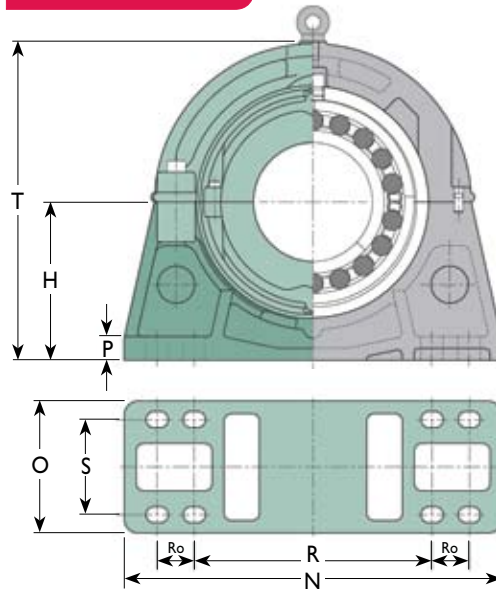

PEDESTAL

Reference	H (mm)	R		Ro (mm)	S (mm)	Bolts			N (mm)	O (mm)	P (mm)	T (mm)	Mass (Kg)	Shaft Diameter d (mm)
		Min. (mm)	Max. (mm)			No.	Metric Size	Inch Size						
P15	292	482	522	-	140	4	M30	1¼"	686	228	44	585	114	260
P16	311	514	554	-	140	4	M30	1¼"	724	228	48	620	142	
P36	356	576	616	-	204	4	M36	1½"	812	292	54	710	212	
P63	394	650	690	-	304	4	M42	1¾"	914	406	76	790	392	
P16	311	514	554	-	140	4	M30	1¼"	724	228	48	620	142	270
P16	311	514	554	-	140	4	M30	1¼"	724	228	48	620	142	275
P16	311	514	554	-	140	4	M30	1¼"	724	228	48	620	142	280
P37	378	514	554	101	254	8	M30	1¼"	914	330	60	760	292	
P64	425	590	630	101	318	8	M36	1½"	1028	406	76	850	495	
P83	368	482	522	120	178	8	M36	1½"	940	280	70	785	205	
P17	343	564	604	-	178	4	M30	1¼"	762	254	50	685	169	290
P65	457	654	694	101	330	8	M36	1½"	1092	420	76	915	586	
P17	343	564	604	-	178	4	M30	1½"	762	254	50	685	169	300
P38	394	546	586	101	254	8	M30	1½"	958	330	60	790	330	
P65	457	654	694	101	330	8	M36	1½"	1092	420	76	915	586	

- (3) Maximum fillet radii of abutments:
inner race: 2.3mm
outer race: 2mm

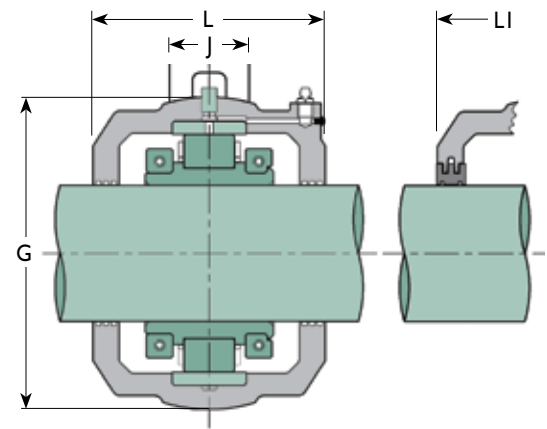
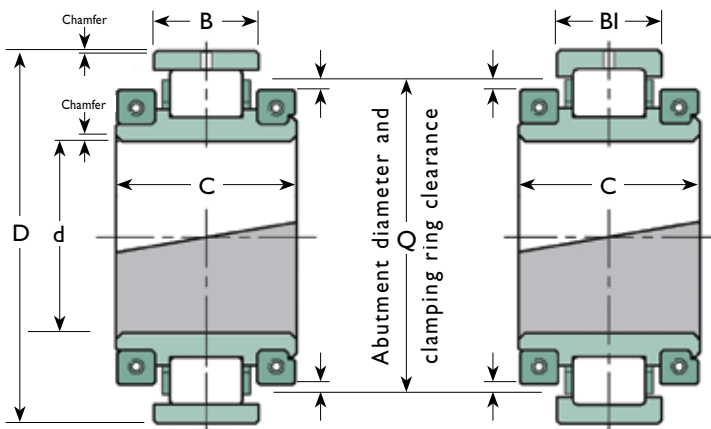

ROLLER BEARING

Shaft Diameter d (mm)	Reference (1)	Bearing Ratings				Principal Dimensions					Axial Movement (2)		Mass (kg)
		Cr (kN)	Cor (kN)	Ca (kN)	Max. Speed (rpm)	D (mm)	C (mm)	B (mm)	BI (mm)	Q (mm)	Usual (mm)	Max. (mm)	
320	01 B 320M	894	1638	89.0	590	463.55	136.0	74.6	74.6	432	10	23	72
	02 B 320M	1570	2622	144	550	527.05	192.0	106.4	106.4	478	15	30	150
	03 B 320M	2529	3795	199	500	622.30	272.0	160.4	160.4	550	22	48	327
330	01 B 330M	894	1638	89.0	590	463.55	136.0	74.6	74.6	432	10	23	72
	02 B 330M	1570	2622	144	550	527.05	192.0	106.4	106.4	478	15	30	150
340	01 B 1300-340M	894	1638	89.0	590	463.55	136.0	74.6	74.6	432	10	23	72
	01 B 340M	935	1774	99.6	540	488.95	136.0	74.6	74.6	456	10	23	78
	02 B 340M	1744	2940	159	500	565.15	200.0	115.9	115.9	514	16	35	182
	03E B 340M	2750	4392	214	460	615.95	279.0	158.0	158.0	556	22	44	318
350	01 B 350M	935	1774	99.6	540	488.95	136.0	74.6	74.6	456	10	23	78
	02 B 350M	1744	2940	159	500	565.15	200.0	115.9	115.9	514	16	35	182
360	01 B 1400-360M	935	1774	99.6	540	488.95	136.0	74.6	74.6	456	10	23	78
	01 B 360M	1005	1925	110	500	520.70	140.0	76.2	76.2	486	10	23	86
	02 B 360M	1744	2940	159	500	565.15	200.0	115.9	115.9	514	16	35	182
	03E B 360M	2750	4392	214	460	615.95	279.0	158.0	158.0	556	22	44	318
	03X B 360M	2785	4377	226	460	647.70	279.0	160.4	160.4	575	22	48	372

CARTRIDGE

References (1)		Principal Dimensions				Mass (kg)
Cartridge for Felt seals	Cartridge for ATL seals	G (mm)	J (mm)	L (mm)	LI (mm)	
01 C 320M	01 C 18	520.70	95	260	272	106
02 C 320M	02 C 39	587.40	128	298	330	172
03 C 320M	03 C 66	717.60	170	368	418	273
01 C 330M	01 C 18	520.70	95	260	272	106
02 C 330M	02 C 39	587.40	128	298	330	172
01 C 1300-340M	01 C 18	520.70	95	260	272	106
01 C 340M	01 C 19	546.10	98	260	272	117
02 C 340M	02 C 40	628.70	146	305	342	186
03E C 340M	03E C 86	704.90	196	432	432	385
01 C 350M	01 C 19	546.10	98	260	272	117
02 C 350M	02 C 40	628.70	146	305	342	186
01 C 1400-360M	01 C 19	546.10	98	260	272	117
01 C 360M	01 C 20	571.50	98	260	280	126
02 C 360M	02 C 40	628.70	146	305	342	186
03E C 360M	03E C 86	704.90	196	432	432	385
03X C 360M	03X C 67	739.80	196	380	426	353

(1) Add 'EX' or 'GR' to reference for expansion type or fixed type respectively, e.g.:
 bearing: 01 B 340M EX
 cartridge: 01 C 340M EX or 01 C 19 EX
 Pedestals are common between expansion and fixed type units

(2) Total available axial movement given. Maximum offset from centreline half this amount. 'Usual' axial movement denotes maximum recommended range of running positions of EX bearing for optimum performance. 'Maximum' axial movement denotes available movement before fouling occurs in standard Cooper cartridge.

METRIC BEARINGS, CARTRIDGES AND PEDESTALS FROM 320mm TO 360mm BORE SIZE

4 Bolt

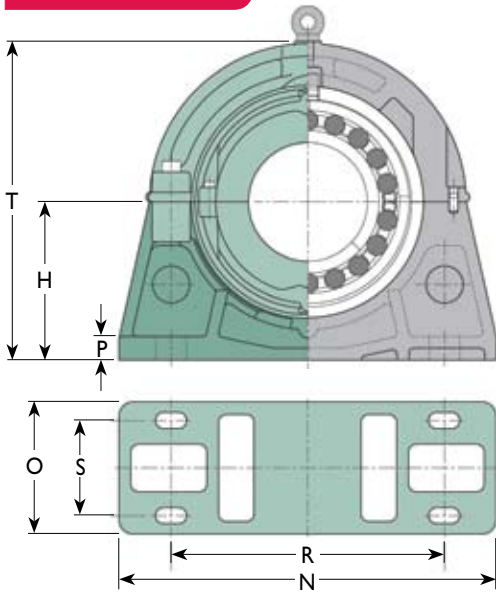

8 Bolt

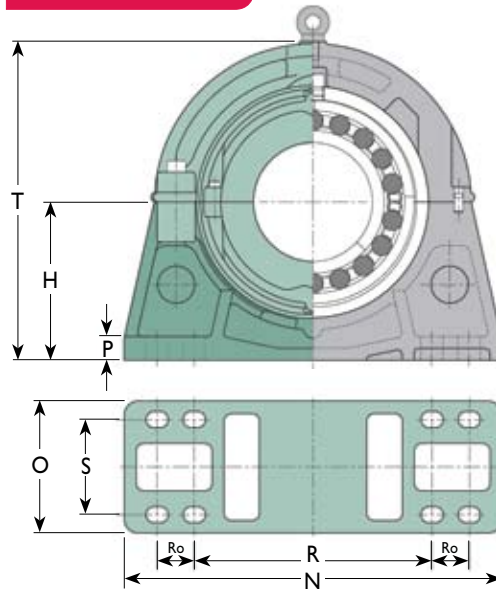

PEDESTAL

Reference	H (mm)	R		Ro (mm)	S (mm)	Bolts			N (mm)	O (mm)	P (mm)	T (mm)	Mass (Kg)	Shaft Diameter d (mm)
		Min. (mm)	Max. (mm)			No.	Metric Size	Inch Size						
P18	368	602	642	-	178	4	M36	1½"	812	254	54	735	196	320
P39	419	590	630	101	210	8	M30	1½"	1016	292	64	840	383	
P66	518	742	782	108	266	8	M36	1½"	1194	356	80	1035	655	
P18	368	602	642	-	178	4	M36	1½"	812	254	54	735	196	330
P39	419	590	630	101	210	8	M30	1¼"	1016	292	64	840	383	
P18	368	602	642	-	178	4	M36	1½"	812	254	54	735	196	340
P19	387	634	674	-	166	4	M36	1½"	850	254	57	775	213	
P40	451	640	680	102	280	8	M36	1½"	1092	368	67	900	429	
P86	470	634	686	134	190	8	M42	1¾"	1220	318	82	1000	464	
P19	387	634	674	-	166	4	M36	1½"	850	254	57	775	213	350
P40	451	640	680	102	280	8	M36	1½"	1092	368	67	900	429	
P19	387	634	674	-	166	4	M36	1½"	850	254	57	775	213	360
P20	397	656	696	-	166	4	M36	1½"	902	254	60	795	288	
P40	451	640	680	102	280	8	M36	1½"	1092	368	67	900	429	
P86	470	634	686	134	190	8	M42	1¾"	1220	318	82	1000	464	
P67	533	758	810	114	266	8	M42	1¾"	1244	368	90	1065	820	

- (3) Maximum fillet radii of abutments:
inner race: 2.3mm
outer race: 2mm

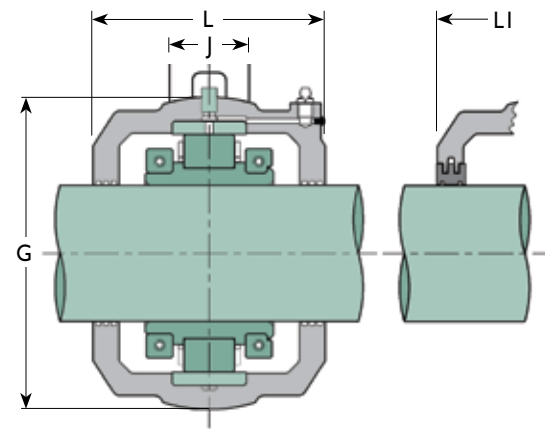
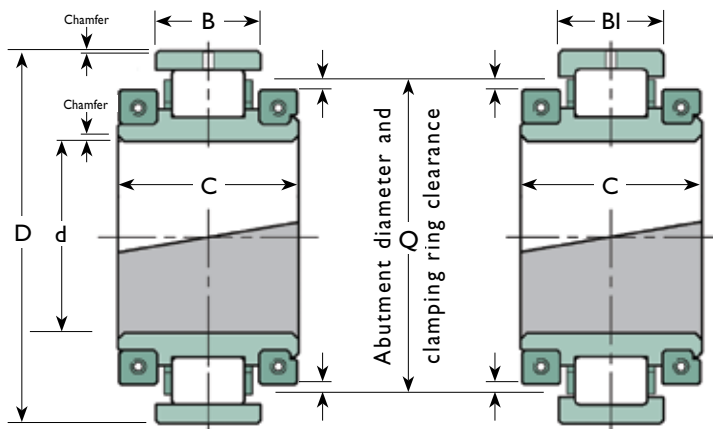

ROLLER BEARING

Shaft Diameter d (mm)	Reference (1)	Bearing Ratings				Principal Dimensions					Axial Movement (2)		Mass (kg)
		Cr (kN)	Cor (kN)	Ca (kN)	Max. Speed (rpm)	D (mm)	C (mm)	B (mm)	BI (mm)	Q (mm)	Usual (mm)	Max. (mm)	
380	01 B 380M	1005	1925	110	500	520.70	140.0	76.2	76.2	486	10	23	86
	02 B 380M	1862	3254	174	460	584.20	200.0	111.1	111.1	536	16	30	186
	03 B 380M	3019	4800	251	420	685.80	292.0	166.7	166.7	610	23	50	431
390	01 B 390M	1048	2071	116	460	546.10	140.0	76.2	76.2	512	10	23	95
400	01 B 400M	1048	2071	116	460	546.10	140.0	76.2	76.2	512	10	23	95
	02 B 400M	1948	3438	188	430	615.95	200.0	115.9	115.9	566	16	33	209
	03 B 400M	3019	4800	251	420	685.80	292.0	166.7	166.7	610	23	50	431
420	01 B 420M	1089	2218	121	430	571.50	140.0	76.2	76.2	538	10	22	104
	02 B 420M	2069	3702	202	400	647.70	200.0	119.1	119.1	596	17	33	241
	03E B 420M	3474	6006	276	360	700.00	284.0	160.0	160.0	640	23	42	395
440	01 B 440M	1129	2366	127	410	596.90	140.0	76.2	76.2	562	10	22	114
	02 B 440M	2195	4057	216	380	666.75	200.0	115.9	115.9	618	17	30	250
	03E B 440M	3474	6006	276	360	700.00	284.0	160.0	160.0	640	23	42	395
460	01 B 460M	1129	2366	127	410	596.90	140.0	76.2	76.2	562	10	22	114
	02 B 460M	2195	4057	216	380	666.75	200.0	115.9	115.9	618	17	30	250
	03E B 460M	3650	6156	302	340	740.00	294.0	170.0	170.0	680	24	46	431
	03X B 460M	3771	6186	309	340	800.10	300.0	187.4	187.4	715	26	56	630

CARTRIDGE

References (1)		Principal Dimensions				Mass (kg)
Cartridge for Felt seals	Cartridge for ATL seals	G (mm)	J (mm)	L (mm)	LI (mm)	
01 C 380M	01 C 20	571.50	98	260	280	126
02 C 380M	02 C 41	647.70	146	305	342	209
03 C 380M	03 C 68	774.70	202	400	438	399
01 C 390M	01 C 21	603.30	102	280	286	141
01 C 400M	01 C 21	603.30	102	280	286	141
02 C 400M	02 C 42	685.80	146	324	350	254
03 C 400M	03 C 68	774.70	202	400	438	399
01 C 420M	01 C 22	628.70	102	292	298	150
02 C 420 M	02 C 43	717.60	146	324	356	264
03E C 420M	03E C 89	788.00	200	440	442	408
01 C 440M	01 C 23	650.90	108	304	310	151
02 C 440M	02 C 44	733.40	146	324	356	265
03E C 440M	03E C 89	788.00	200	440	442	408
01 C 460M	01 C 23	650.90	108	304	310	151
02 C 460M	02 C 44	733.40	146	324	356	265
03E C 460M	03E C 90	840.00	200	450	450	454
03X C 460M	03X C 71	914.40	235	476	482	740

(1) Add 'EX' or 'GR' to reference for expansion type or fixed type respectively, e.g.:
bearing: 01 B 420M EX
cartridge: 01 C 420M EX or 01 C 22 EX
Pedestals are common between expansion and fixed type units

(2) Total available axial movement given. Maximum offset from centreline half this amount. 'Usual' axial movement denotes maximum recommended range of running positions of EX bearing for optimum performance. 'Maximum' axial movement denotes available movement before fouling occurs in standard Cooper cartridge.

METRIC BEARINGS, CARTRIDGES AND PEDESTALS FROM 380mm TO 460mm BORE SIZE

4 Bolt

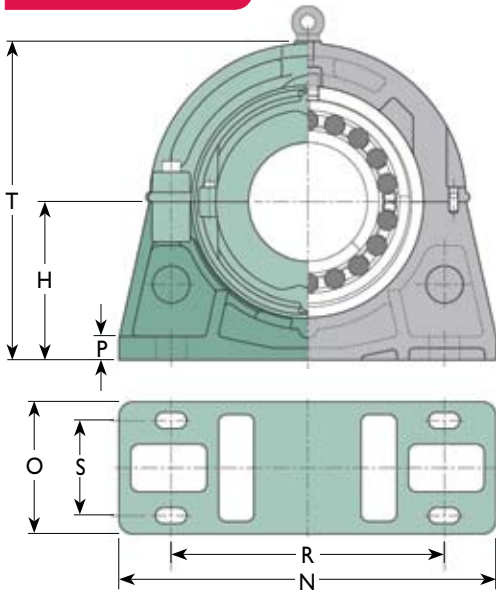

8 Bolt

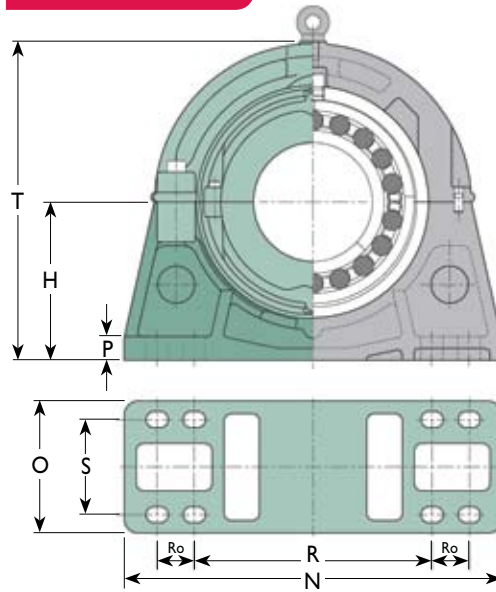

PEDESTAL

Reference	H (mm)	R		Ro (mm)	S (mm)	Bolts			N (mm)	O (mm)	P (mm)	T (mm)	Mass (Kg)	Shaft Diameter d (mm)
		Min. (mm)	Max. (mm)			No.	Metric Size	Inch Size						
P20	397	656	696	-	166	4	M36	1½"	902	254	60	795	288	
P41	464	662	702	102	280	8	M36	1½"	1092	368	67	925	445	380
P68	559	780	832	115	292	8	M42	1¾"	1270	394	92	1120	859	
P21	432	704	744	-	166	4	M36	1½"	940	254	67	865	309	390
P21	432	704	744	-	166	4	M36	1½"	940	254	67	865	309	
P42	495	710	750	102	280	8	M36	1½"	1168	368	70	990	537	400
P68	559	780	832	115	292	8	M42	1¾"	1270	394	92	1120	859	
P22	445	736	776	-	166	4	M36	1½"	966	254	67	890	316	
P43	514	748	788	102	280	8	M36	1½"	1194	368	70	1030	564	420
P89	508	664	716	150	210	8	M48	2"	1270	360	90	1075	482	
P23	464	768	808	-	190	4	M42	1¾"	1042	280	70	925	370	
P44	533	768	808	104	280	8	M36	1½"	1244	368	73	1070	564	440
P89	508	664	716	150	210	8	M48	2"	1270	360	90	1075	482	
P23	464	768	808	-	190	4	M42	1¾"	1042	280	70	925	370	
P44	533	768	808	104	280	8	M36	1½"	1244	368	73	1070	564	460
P90	550	754	806	150	220	8	M48	2"	1370	380	95	1165	705	
P71	660	908	960	178	362	8	M48	2"	1574	470	108	1320	1330	

- (3) Maximum fillet radii of abutments:
inner race: 2.3mm
outer race: 2mm

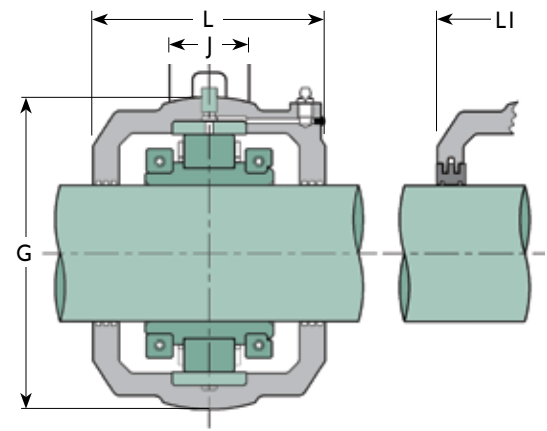
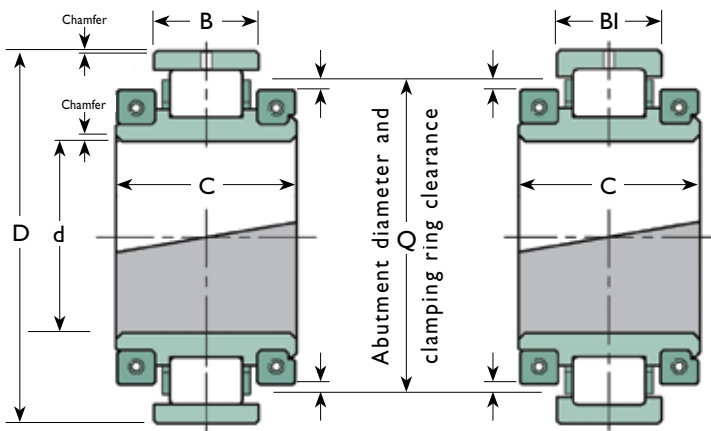

ROLLER BEARING

Shaft Diameter d (mm)	Reference (1)	Bearing Ratings				Principal Dimensions					Axial Movement (2)		Mass (kg)
		Cr (kN)	Cor (kN)	Ca (kN)	Max. Speed (rpm)	D (mm)	C (mm)	B (mm)	BI (mm)	Q (mm)	Usual (mm)	Max. (mm)	
480	01 B 480M	1169	2433	133	380	628.65	144.0	81.0	81.0	594	11	24	128
	02 B 480M	2313	4419	230	360	698.50	223.0	119.1	119.1	648	17	33	263
	03X B 480M	3771	6186	309	340	800.10	300.0	187.4	187.4	715	26	56	630
500	01 B 500M	1213	2593	138	360	654.05	168.0	80.2	80.2	618	11	23	136
	02 B 500M	2430	4776	244	340	717.55	226.0	115.9	115.9	670	17	30	272
	03 B 500M	4087	7042	347	310	850.90	300.0	187.4	187.4	765	26	56	730
530	01 B 530M	1253	2755	141	340	692.15	168.0	81.0	81.0	650	11	23	164
	02 B 530M	2658	5137	258	330	762.00	229.0	119.1	119.1	710	18	27	309
	03 B 530M	4087	7042	347	310	850.90	300.0	187.4	187.4	765	26	56	730
560	01 B 560M	1294	2916	142	330	717.55	168.0	81.0	81.0	675	11	23	178
	02 B 560M	2790	5556	272	310	793.75	233.0	122.2	122.2	738	18	30	336
	03E B 560M	4669	8511	383	280	863.60	310.0	196.9	196.9	800	28	56	635
580	01 B 580M	1387	3138	144	310	749.30	172.0	84.1	84.1	706	11	25	195
	02 B 580M	2336	4836	227	300	812.80	232.0	119.1	119.1	754	16	37	340
600	01 B 600M	1431	3311	147	300	774.70	172.0	84.1	84.1	732	11	25	210
	02 B 600M	2905	5992	300	290	838.20	214.0	119.1	119.1	786	18	27	381
	03E B 600M	4887	9130	400	270	890.00	310.0	184.0	184.0	826	27	47	680

CARTRIDGE

References (1)		Principal Dimensions				Mass (kg)
Cartridge for Felt seals	Cartridge for ATL seals	G (mm)	J (mm)	L (mm)	LI (mm)	
01 C 480M	01 C 24	682.60	108	304	324	162
02 C 480M	02 C 45	762.00	146	338	374	272
03X C 480M	03X C 71	914.40	235	476	482	740
01 C 500M	01 C 25	717.60	114	304	330	192
02 C 500M	02 C 46	787.40	146	350	374	323
03 C 500M	03 C 94	958.90	204	495	508	770
01 C 530M	01 C 26	755.70	114	330	336	226
02 C 530M	02 C 47	831.90	150	350	374	351
03 C 530M	03 C 94	958.90	204	495	508	770
01 C 560M	01 C 27	781.10	114	336	342	252
02 C 560M	02 C 48	866.80	152	356	380	379
03E C 560M	03E C 94	958.90	204	490	490	671
01 C 580M	01 C 28	816.00	120	342	348	273
02 C 580M	02 C 49	882.70	152	356	380	386
01 C 600M	01 C 29	841.40	120	342	348	290
02 C 600M	02 C 50	914.40	152	388	394	454
03E C 600M	03E C 95	990.00	204	490	490	720

(1) Add 'EX' or 'GR' to reference for expansion type or fixed type respectively, e.g.:
 bearing: 01 B 480M EX
 cartridge: 01 C 480M EX or 01 C 24 EX
 Pedestals are common between expansion and fixed type units

(2) Total available axial movement given. Maximum offset from centreline half this amount. 'Usual' axial movement denotes maximum recommended range of running positions of EX bearing for optimum performance. 'Maximum' axial movement denotes available movement before fouling occurs in standard Cooper cartridge.

METRIC BEARINGS, CARTRIDGES AND PEDESTALS FROM 480mm TO 600mm BORE SIZE

4 Bolt

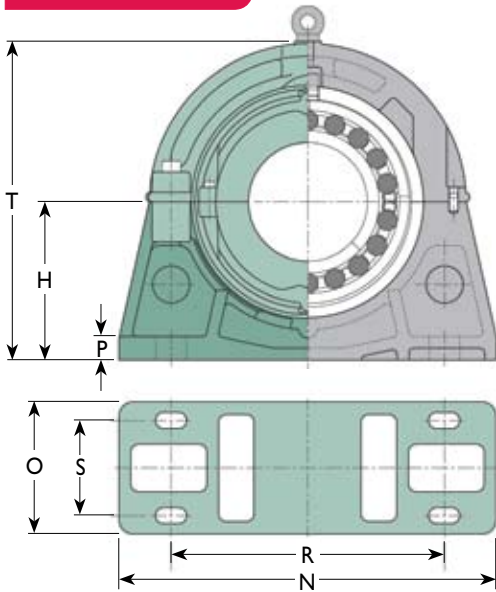

8 Bolt

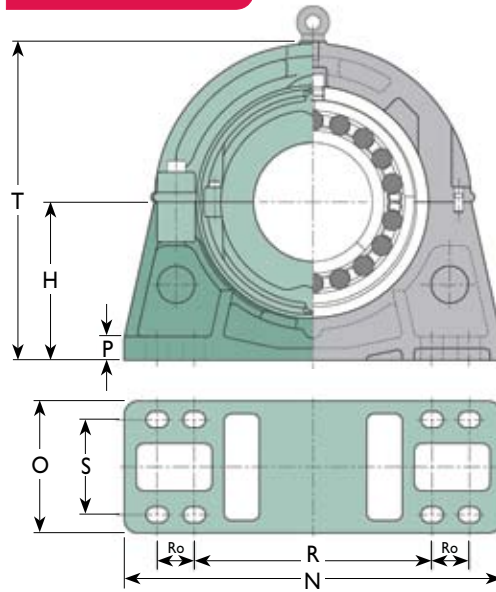

PEDESTAL

Reference	H (mm)	R		Ro (mm)	S (mm)	Bolts			N (mm)	O (mm)	P (mm)	T (mm)	Mass (Kg)	Shaft Diameter d (mm)
		Min. (mm)	Max. (mm)			No.	Metric Size	Inch Size						
P24	483	796	836	-	188	4	M42	1 3/4"	1092	304	73	965	402	
P45	552	792	832	115	280	8	M36	1 1/2"	1270	368	76	1110	690	480
P71	660	908	960	178	362	8	M48	2"	1574	470	108	1320	1330	
P25	489	824	864	-	216	4	M42	1 3/4"	1092	304	76	980	402	
P46	572	824	864	115	280	8	M36	1 1/2"	1296	368	80	1145	677	500
P94	622	914	966	165	242	8	M56	2 1/4"	1600	406	102	1340	1000	
P26	533	884	924	-	206	4	M42	1 3/4"	1194	304	80	1065	495	
P47	591	870	910	114	280	8	M36	1 1/2"	1398	368	83	1180	905	530
P94	622	914	966	165	242	8	M56	2 3/4"	1600	406	102	1340	1000	
P27	552	916	956	-	206	4	M42	1 3/4"	1220	304	83	1110	570	
P48	616	904	956	114	280	8	M42	1 3/4"	1422	382	86	1230	965	560
P94	622	914	966	165	242	8	M56	2 1/4"	1600	406	102	1340	1000	
P28	578	857	896	102	220	8	M36	1 1/2"	1346	304	90	1156	630	580
P49	635	932	984	115	280	8	M42	1 3/4"	1448	382	90	1270	1000	
P29	597	888	928	105	220	8	M36	1 1/2"	1372	304	90	1200	630	
P50	673	984	1036	114	280	8	M42	1 3/4"	1524	382	92	1345	1050	600
P95	622	914	966	165	242	8	M56	2 1/4"	1600	406	102	1340	930	

- (3) Maximum fillet radii of abutments:
 inner race: 2.3mm
 outer race: 2mm

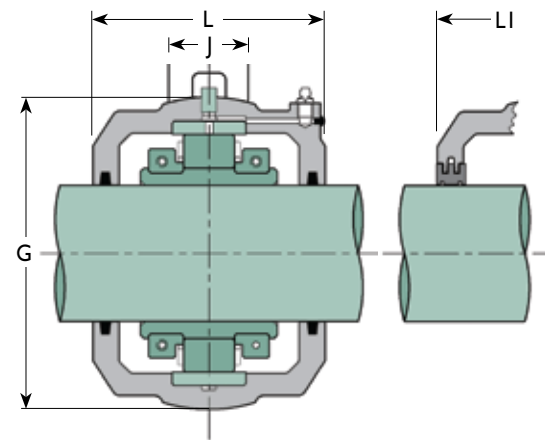
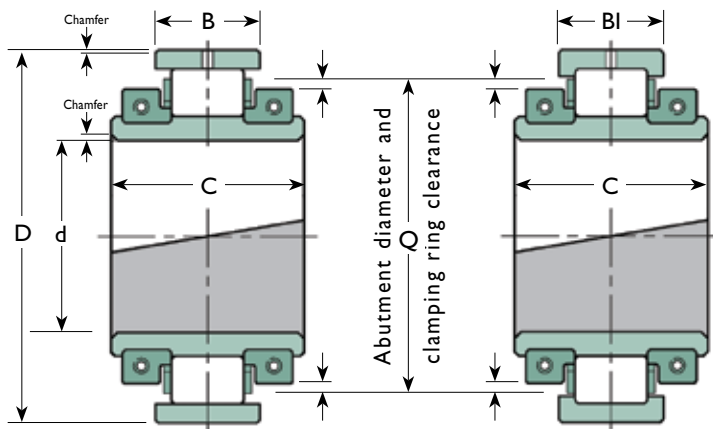

ROLLER BEARING

Shaft Diameter d (in)	Reference (1)	Equivalent Metric Bearing (4)	Bearing Ratings				Principal Dimensions					Axial Movement (2)		Mass (kg)
			Cr (kN)	Cor (kN)	Ca (kN)	Max. Speed (rpm)	D (mm)	C (mm)	B (mm)	BI (mm)	Q (mm)	Usual (mm)	Max. (mm)	
1 ³ / ₁₆	01 B 103	01 B 40M	67	67	3.2	5400	84.14	50.1	23.8	23.8	75	3.5	5.5	1.2
1 ¹ / ₄	01 B 104	01 B 40M	67	67	3.2	5400	84.14	50.1	23.8	23.8	75	3.5	5.5	1.2
1 ⁷ / ₁₆	01 B 107	01 B 40M	67	67	3.2	5400	84.14	50.1	23.8	23.8	75	3.5	5.5	1.2
1 ¹ / ₂	01 B 108	01 B 40M	67	67	3.2	5400	84.14	50.1	23.8	23.8	75	3.5	5.5	1.2
1 ¹¹ / ₁₆	01E B 111	01E B 50M	95	105	3.8	4630	98.42	55.7	25.4	25.4	90	4	5	1.5
1 ³ / ₄	01E B 112	01E B 50M	95	105	3.8	4630	98.42	55.7	25.4	25.4	90	4	5	1.5
1 ⁵ / ₈	01E B 115	01E B 50M	95	105	3.8	4630	98.42	55.7	25.4	25.4	90	4	5	1.5
	02 B 115	02 B 50M	119	125	6.2	4350	107.95	67.5	35.0	35.0	98	5	10.5	2.0
2	01E B 200	01E B 50M	95	105	3.8	4630	98.42	55.7	25.4	25.4	90	4	5	1.5
	02 B 200	02 B 50M	119	125	6.2	4350	107.95	67.5	35.0	35.0	98	5	10.5	2.0
2 ³ / ₁₆	01E B 203	01E B 60M	135	157	7.2	3940	114.30	55.7	27.0	27.0	105	4.5	4.5	1.8
	02 B 203	02 B 60M	168	193	8.8	3680	127.00	72.3	38.9	38.9	116	5.5	11	3.0
2 ¹ / ₄	01E B 204	01E B 60M	135	157	7.2	3940	114.30	55.7	27.0	27.0	105	4.5	4.5	1.8
	02 B 204	02 B 60M	168	193	8.8	3680	127.00	72.3	38.9	38.9	116	5.5	11	3.0
2 ⁷ / ₁₆	01E B 207	01E B 60M	135	157	7.2	3940	114.30	55.7	27.0	27.0	105	4.5	4.5	1.8
	02 B 207	02 B 60M	168	193	8.8	3680	127.00	72.3	38.9	38.9	116	5.5	11	3.0

CARTRIDGE

References (1)		Principal Dimensions				Mass (kg)
Cartridge for Felt seals	Cartridge for ATL seals	G (mm)	J (mm)	L (mm)	LI (mm)	
01 C 103	01 C 01	100.00	25	86	86	2
01 C 104	01 C 01	100.00	25	86	86	2
01 C 107	01 C 01	100.00	25	86	86	2
01 C 108	01 C 01	100.00	25	86	86	2
01 C 111	01 C 02	117.48	25	98	98	2.5
01 C 112	01 C 02	117.48	25	98	98	2.5
01 C 115	01 C 02	117.48	25	98	98	2.5
02 C 115	02 C 03	134.94	32	114	114	4
01 C 200	01 C 02	117.48	25	98	98	2.5
02 C 200	02 C 03	134.94	32	114	114	4
01 C 203	01 C 03	134.94	32	104	104	3.2
02 C 203	02 C 04	157.16	38	126	126	7
01 C 204	01 C 03	134.94	32	104	104	3.2
02 C 204	02 C 04	157.16	38	126	126	7
01 C 207	01 C 03	134.94	32	104	104	3.2
02 C 207	02 C 04	157.16	38	126	126	7

(1) Add 'EX' or 'GR' to reference for expansion type or fixed type respectively, e.g.: bearing: 01E B 115 EX
cartridge: 01 C 115 EX or 01 C 02 EX
Pedestals are common between expansion and fixed type units

(2) Total available axial movement given. Maximum offset from centreline half this amount.
"Usual" axial movement denotes maximum recommended range of running positions of EX bearing for optimum performance.
"Max." axial movement denotes available movement before fouling occurs in standard Cooper cartridge.

INCH-SIZE BEARINGS, CARTRIDGES AND PEDESTALS TO 2⁷/₁₆" BORE SIZE

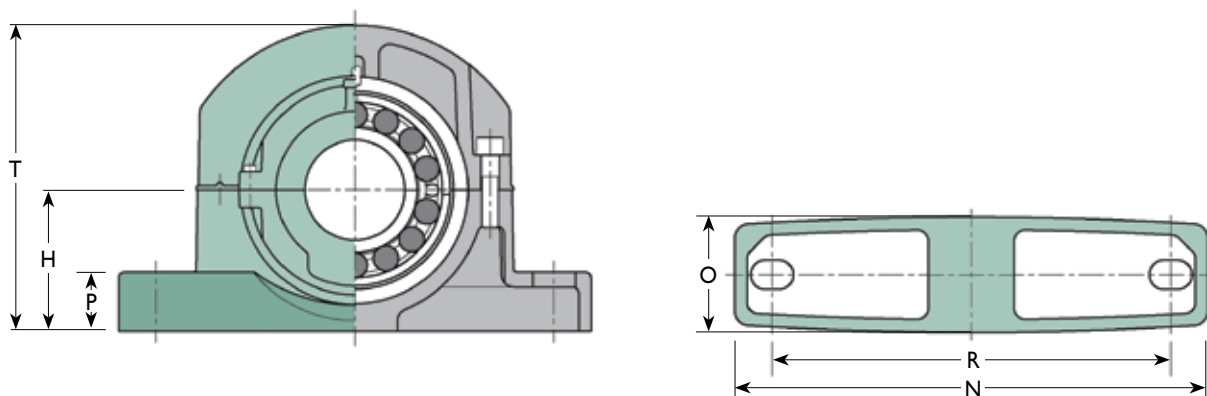

PEDESTAL

Reference	H (mm)	R		Ro (mm)	S (mm)	Bolts			N (mm)	O (mm)	P (mm)	T (mm)	Mass (Kg)	Shaft Diameter d (in)
		Min. (mm)	Max. (mm)			No.	Metric Size	Inch Size						
P01	60	172	192	-	-	2	M12	½"	228	60	22	138	2.5	1 ³ / ₁₆
P01	60	172	192	-	-	2	M12	½"	228	60	22	138	2.5	1 ¹ / ₄
P01	60	172	192	-	-	2	M12	½"	228	60	22	138	2.5	1 ³ / ₁₆
P01	60	172	192	-	-	2	M12	½"	228	60	22	138	2.5	1 ¹ / ₂
P02	70	203	227	-	-	2	M16	5/8"	270	60	25	158	3.2	1 ¹¹ / ₁₆
P02	70	203	227	-	-	2	M16	5/8"	270	60	25	158	3.2	1 ³ / ₄
P02	70	203	227	-	-	2	M16	5/8"	270	60	25	158	3.2	1 ⁵ / ₁₆
P03	80	226	242	-	-	2	M16	5/8"	280	70	32	180	4.9	1 ⁵ / ₁₆
P02	70	203	227	-	-	2	M16	5/8"	270	60	25	158	3.2	2
P03	80	226	242	-	-	2	M16	5/8"	280	70	32	180	4.9	
P03	80	226	242	-	-	2	M16	5/8"	280	70	32	180	4.9	2 ³ / ₁₆
P04	95	260	280	-	-	2	M20	¾"	330	76	38	208	6.9	
P03	80	226	242	-	-	2	M16	5/8"	280	70	32	180	4.9	2 ¹ / ₄
P04	95	260	280	-	-	2	M20	¾"	330	76	38	208	6.9	
P03	80	226	242	-	-	2	M16	5/8"	280	70	32	180	4.9	2 ⁷ / ₁₆
P04	95	260	280	-	-	2	M20	¾"	330	76	38	208	6.9	

(3) Maximum fillet radii of abutments:
inner race: 1.2mm
outer race: 0.4mm

(4) Refer to data on equivalent metric bearing for vibration data, screw data and lubrication details.

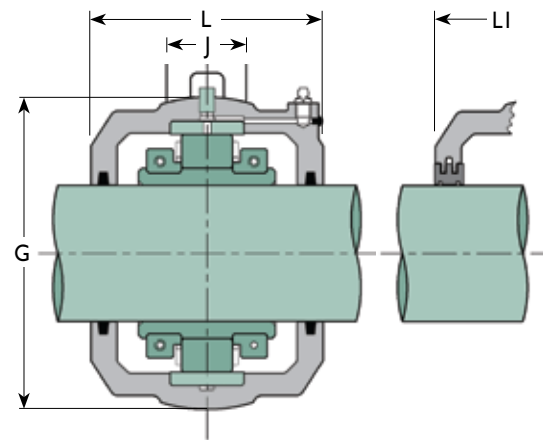
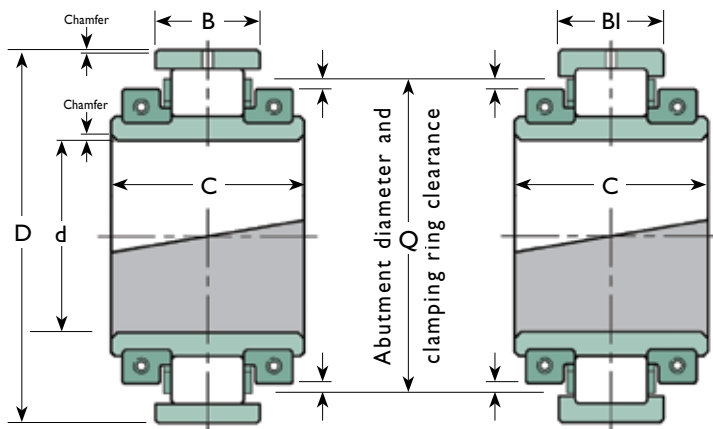

ROLLER BEARING

Shaft Diameter d (in)	Reference (1)	Equivalent Metric Bearing (4)	Bearing Ratings				Principal Dimensions					Axial Movement (2)		Mass (kg)
			Cr (kN)	Cor (kN)	Ca (kN)	Max. Speed (rpm)	D (mm)	C (mm)	B (mm)	BI (mm)	Q (mm)	Usual (mm)	Max. (mm)	
2½	01E B 208	01E B 60M	135	157	7.2	3940	114.30	55.7	27.0	27.0	105	4.5	4.5	1.8
	02 B 208	02 B 60M	168	193	8.8	3680	127.00	72.3	38.9	38.9	116	5.5	11	3.0
2¼	01E B 211	01E B 75M	166	197	10.8	3310	133.35	61.2	31.8	31.8	124	5	7	2.5
	02 B 211	02 B 75M	229	268	10.6	3080	149.22	82.6	46.1	46.1	138	6	13.5	5.0
2¾	01E B 212	01E B 75M	166	197	10.8	3310	133.35	61.2	31.8	31.8	124	5	7	2.5
	02 B 212	02 B 75M	229	268	10.6	3080	149.22	82.6	46.1	46.1	138	6	13.5	5.0
2½	100 B 215	100 B 75M	91	128	7.0	4125	114.30	48.0	27.0	27.0	102	3.5	7	1.2
	01E B 215	01E B 75M	166	197	10.8	3310	133.35	61.2	31.8	31.8	124	5	7	2.5
	02 B 215	02 B 75M	229	268	10.6	3080	149.22	82.6	46.1	46.1	138	6	13.5	5.0
3	100 B 300	100 B 75M	91	128	7.0	4125	114.30	48.0	27.0	27.0	102	3.5	7	1.2
	01E B 300	01E B 75M	166	197	10.8	3310	133.35	61.2	31.8	31.8	124	5	7	2.5
	02 B 300	02 B 75M	229	268	10.6	3080	149.22	82.6	46.1	46.1	138	6	13.5	5.0
3⅓	01E B 303	01E B 85M	234	299	13.6	2790	152.40	70.7	38.9	38.9	142	6	10	4.0
	02 B 303	02 B 85M	280	345	17.8	2520	169.86	89.7	48.4	48.4	156	7	14	7.0
3¼	01E B 304	01E B 85M	234	299	13.6	2790	152.40	70.7	38.9	38.9	142	6	10	4.0
	02 B 304	02 B 85M	280	345	17.8	2520	169.86	89.7	48.4	48.4	156	7	14	7.0

CARTRIDGE

References (1)		Principal Dimensions				Mass (kg)
Cartridge for Felt seals	Cartridge for ATL seals	G (mm)	J (mm)	L (mm)	LI (mm)	
01 C 208	01 C 03	134.94	32	104	104	3.2
02 C 208	02 C 04	157.16	38	126	126	7
01 C 211	01 C 04	157.16	38	114	114	5.5
02 C 211	02 C 05	177.80	50	140	140	9
01 C 212	01 C 04	157.16	38	114	114	5.5
02 C 212	02 C 05	177.80	50	140	140	9
100 C 215	100 C 03	134.94	32	104	104	3.6
01 C 215	01 C 04	157.16	38	114	114	5.5
02 C 215	02 C 05	177.80	50	140	140	9
100 C 300	100 C 03	134.94	32	104	104	3.6
01 C 300	01 C 04	157.16	38	114	114	5.5
02 C 300	02 C 05	177.80	50	140	140	9
01 C 303	01 C 05	177.80	50	136	136	7
02 C 303	02 C 06	203.20	50	154	154	10
01 C 304	01 C 05	177.80	50	136	136	7
02 C 304	02 C 06	203.20	50	154	154	10

(1) Add 'EX' or 'GR' to reference for expansion type or fixed type respectively, e.g.: bearing: 01E B 215 EX
cartridge: 01 C 215 EX or 01 C 04 EX
Pedestals are common between expansion and fixed type units

(2) Total available axial movement given. Maximum offset from centreline half this amount.
"Usual" axial movement denotes maximum recommended range of running positions of EX bearing for optimum performance.
"Max." axial movement denotes available movement before fouling occurs in standard Cooper cartridge.

INCH-SIZE BEARINGS, CARTRIDGES AND PEDESTALS FROM 2 1/2" TO 3 1/4" BORE SIZE

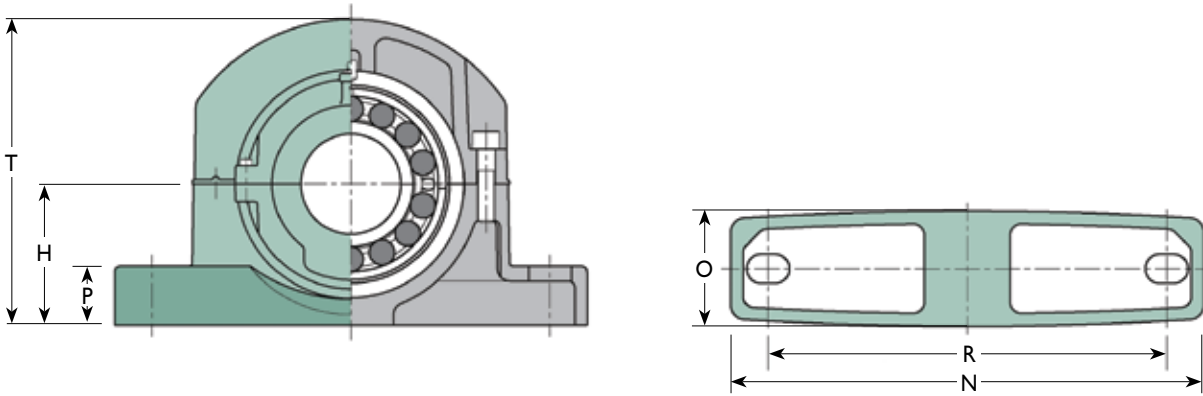

PEDESTAL

Reference	H (mm)	R		Ro (mm)	S (mm)	Bolts			N (mm)	O (mm)	P (mm)	T (mm)	Mass (Kg)	Shaft Diameter d (in)
		Min. (mm)	Max. (mm)			No.	Metric Size	Inch Size						
P03	80	226	242	-	-	2	M16	5/8"	280	70	32	180	4.9	2 1/2
P04	95	260	280	-	-	2	M20	3/4"	330	76	38	208	6.9	
P04	95	260	280	-	-	2	M20	3/4"	330	76	38	208	6.9	2 11/16
P05	112	312	328	-	-	2	M24	7/8"	380	90	44	252	13.3	
P04	95	260	280	-	-	2	M20	3/4"	330	76	38	208	6.9	2 3/4
P05	112	312	328	-	-	2	M24	7/8"	380	90	44	252	13.3	
P03	80	226	242	-	-	2	M16	5/8"	280	70	32	180	4.9	2 5/16
P04	95	260	280	-	-	2	M20	3/4"	330	76	38	208	6.9	
P05	112	312	328	-	-	2	M24	7/8"	380	90	44	252	13.3	
P03	80	226	242	-	-	2	M16	5/8"	280	70	32	180	4.9	3
P04	95	260	280	-	-	2	M20	3/4"	330	76	38	208	6.9	
P05	112	312	328	-	-	2	M24	7/8"	380	90	44	252	13.3	
P05	112	312	328	-	-	2	M24	7/8"	380	90	44	252	13.3	3 3/16
P06	125	342	366	-	-	2	M24	7/8"	420	102	52	272	14.7	
P05	112	312	328	-	-	2	M24	7/8"	380	90	44	252	13.3	3 1/4
P06	125	342	366	-	-	2	M24	7/8"	420	102	52	272	14.7	

(3) Maximum fillet radii of abutments:
inner race: 1.2mm
outer race: 0.4mm

(4) Refer to data on equivalent metric bearing for vibration data, screw data and lubrication details.

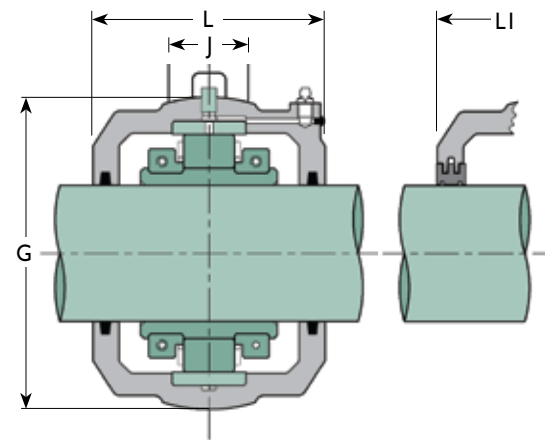
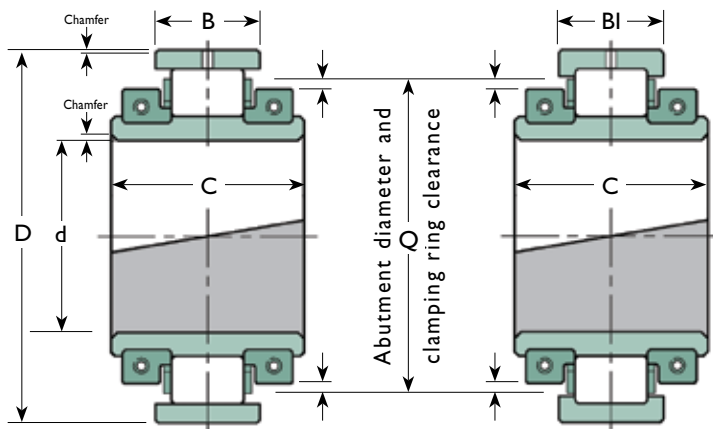

ROLLER BEARING

Shaft Diameter d (in)	Reference (1)	Equivalent Metric Bearing (4)	Bearing Ratings				Principal Dimensions					Axial Movement (2)		Mass (kg)
			Cr (kN)	Cor (kN)	Ca (kN)	Max. Speed (rpm)	D (mm)	C (mm)	B (mm)	BI (mm)	Q (mm)	Usual (mm)	Max. (mm)	
3 1/16	100 B 307	100 B 85M	142	209	12.3	4190	133.35	60.0	31.8	31.8	120	5	6	2.1
	01E B 307	01E B 85M	234	299	13.6	2790	152.40	70.7	38.9	38.9	142	6	10	4.0
	02 B 307	02 B 85M	280	345	17.8	2520	169.86	89.7	48.4	48.4	156	7	14	7.0
3 1/2	01E B 308	01E B 85M	234	299	13.6	2790	152.40	70.7	38.9	38.9	142	6	10	4.0
	02 B 308	02 B 85M	280	345	17.8	2520	169.86	89.7	48.4	48.4	156	7	14	7.0
3 11/16	01E B 311	01E B 100M	320	421	19.6	2340	174.62	81.0	45.3	45.3	162	7	10.5	6.0
	02 B 311	02 B 100M	362	456	25.0	2130	193.68	92.1	51.6	51.6	178	8	13.5	9.0
3 3/4	01E B 312	01E B 100M	320	421	19.6	2340	174.62	81.0	45.3	45.3	162	7	10.5	6.0
	02 B 312	02 B 100M	362	456	25.0	2130	193.68	92.1	51.6	51.6	178	8	13.5	9.0
3 15/16	100 B 315	100 B 100M	191	288	18.3	3090	152.40	65.0	38.9	38.9	140	6	9.0	2.8
	01E B 315	01E B 100M	320	421	19.6	2340	174.62	81.0	45.3	45.3	162	7	10.5	6.0
	02 B 315	02 B 100M	362	456	25.0	2130	193.68	92.1	51.6	51.6	178	8	13.5	9.0
	03 B 315	03 B 100M	610	684	31.2	1820	254.00	136.0	84.2	84.2	219	11	29	30
4	100 B 400	100 B 100M	191	288	18.3	3090	152.40	65.0	38.9	38.9	140	6	9.0	2.8
	01E B 400	01E B 100M	320	421	19.6	2340	174.62	81.0	45.3	45.3	162	7	10.5	6.0
	02 B 400	02 B 100M	362	456	25.0	2130	193.68	92.1	51.6	51.6	178	8	13.5	9.0
	03 B 400	03 B 100M	610	684	31.2	1820	254.00	136.0	84.2	84.2	219	11	29	30

CARTRIDGE

References (1)		Principal Dimensions				Mass (kg)
Cartridge for Felt seals	Cartridge for ATL seals	G (mm)	J (mm)	L (mm)	LI (mm)	
100 B 307	100 C 04	157.16	38	114	114	5.4
01 C 307	01 C 05	177.80	50	136	136	7
02 C 307	02 C 06	203.20	50	154	154	10
01 C 308	01 C 05	177.80	50	136	136	7
02 C 308	02 C 06	203.20	50	154	154	10
01 C 311	01 C 06	203.20	50	134	134	8
02 C 311	02 C 07	231.78	64	146	146	12
01 C 312	01 C 06	203.20	50	134	134	8
02 C 312	02 C 07	231.78	64	146	146	12
100 C 315	100 C 05	177.80	50	136	136	7.4
01 C 315	01 C 06	203.20	50	134	134	8
02 C 315	02 C 07	231.78	64	146	146	12
03 C 315	03 C 54	308.00	95	200	206	41
100 C 400	100 C 05	177.80	50	136	136	7.4
01 C 400	01 C 06	203.20	50	134	134	8
02 C 400	02 C 07	231.78	64	146	146	12
03 C 400	03 C 54	308.00	95	200	206	41

(1) Add 'EX' or 'GR' to reference for expansion type or fixed type respectively,
 e.g.: bearing: 01E B 308 EX
 cartridge: 01 C 308 EX or 01 C 05 EX
 Pedestals are common between expansion and fixed type units

(2) Total available axial movement given. Maximum offset from centreline half this amount.
 "Usual" axial movement denotes maximum recommended range of running positions of EX bearing for optimum performance.
 "Max." axial movement denotes available movement before fouling occurs in standard Cooper cartridge.

INCH-SIZE BEARINGS, CARTRIDGES AND PEDESTALS FROM 3⁷/₁₆" TO 4" BORE SIZE

2 Bolt

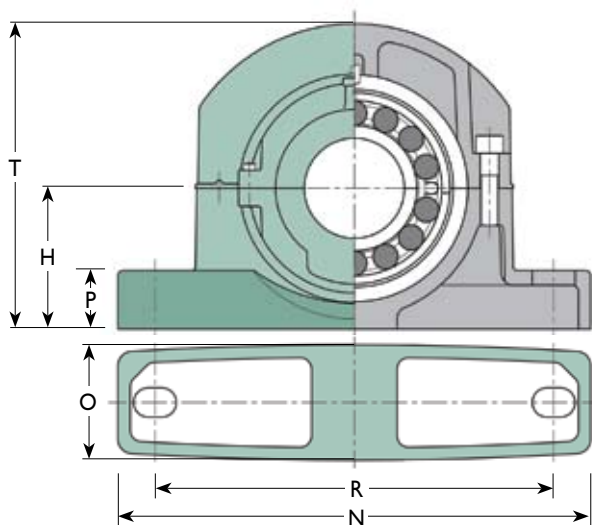

4 Bolt

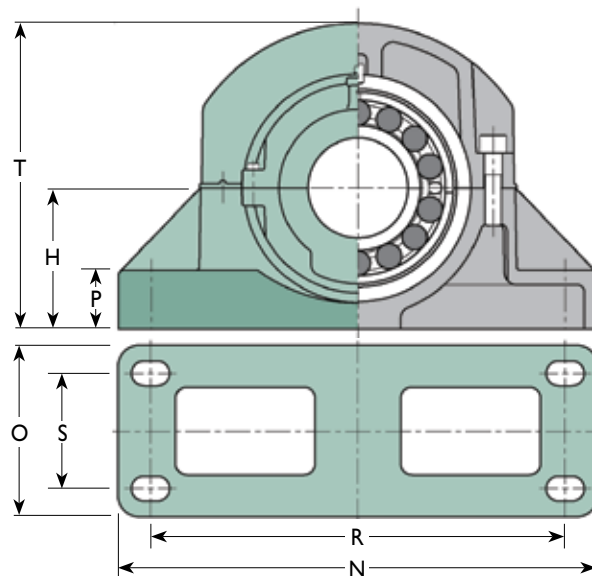

PEDESTAL

Reference	H (mm)	R		Ro (mm)	S (mm)	Bolts			N (mm)	O (mm)	P (mm)	T (mm)	Mass (Kg)	Shaft Diameter d (in)
		Min. (mm)	Max. (mm)			No.	Metric Size	Inch Size						
P04	95	260	280	-	-	2	M20	3/4"	330	76	38	208	6.9	3 ⁷ / ₁₆
P05	112	312	328	-	-	2	M24	7/8"	380	90	44	252	13.3	
P06	125	342	366	-	-	2	M24	7/8"	420	102	52	272	14.7	
P05	112	312	328	-	-	2	M24	7/8"	380	90	44	252	13.3	3 ¹ / ₂
P06	125	342	366	-	-	2	M24	7/8"	420	102	52	272	14.7	
P06	125	342	366	-	-	2	M24	7/8"	420	102	52	272	14.7	3 ¹ / ₁₆
P07	143	374	410	-	-	2	M24	7/8"	466	120	60	314	20.6	
P06	125	342	366	-	-	2	M24	7/8"	420	102	52	272	14.7	3 ³ / ₄
P07	143	374	410	-	-	2	M24	7/8"	466	120	60	314	20.6	
P05	112	312	328	-	-	2	M24	7/8"	380	90	44	252	13.3	3 ¹⁵ / ₁₆
P06	125	342	366	-	-	2	M24	7/8"	420	102	52	272	14.7	
P07	143	374	410	-	-	2	M24	7/8"	466	120	60	314	20.6	
P54	191	426	450	-	82	4	M24	7/8"	514	152	38	405	61	
P05	112	312	328	-	-	2	M24	7/8"	380	90	44	252	13.3	4
P06	125	342	366	-	-	2	M24	7/8"	420	102	52	272	14.7	
P07	143	374	410	-	-	2	M24	7/8"	466	120	60	314	20.6	
P54	191	426	450	-	82	4	M24	7/8"	514	152	38	405	61	

- (3) Maximum fillet radii of abutments:
 inner race: up to and including 3¹/₂" shaft size: 1.2mm
 over 3¹/₂" shaft size: 2mm
 outer race: 01E and 02 Series up to and including 3¹/₂" shaft size,
 100 Series: 0.4mm
 01E and 02 Series over 3¹/₂" shaft size: 0.8mm
 03 Series: 2mm

- (4) Refer to data on equivalent metric bearing for vibration data, screw data and lubrication details.

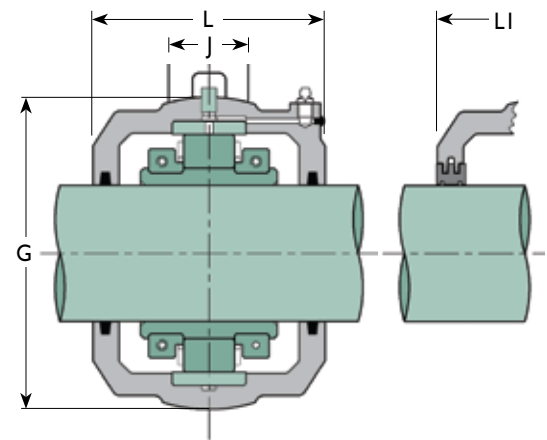
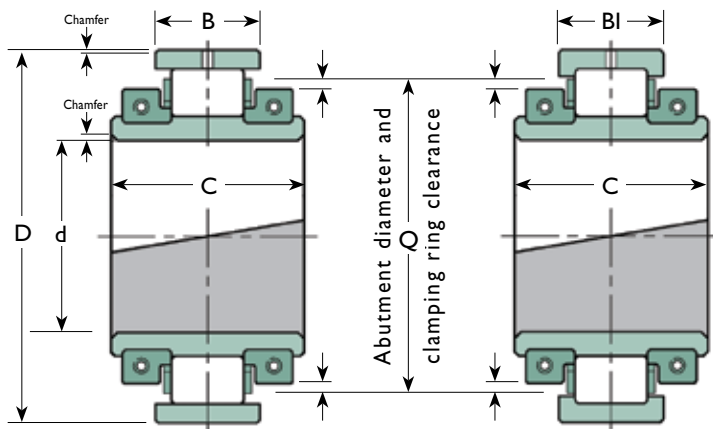

ROLLER BEARING

Shaft Diameter d (in)	Reference (1)	Equivalent Metric Bearing (4)	Bearing Ratings				Principal Dimensions					Axial Movement (2)		Mass (kg)
			Cr (kN)	Cor (kN)	Ca (kN)	Max. Speed (rpm)	D (mm)	C (mm)	B (mm)	BI (mm)	Q (mm)	Usual (mm)	Max. (mm)	
4 ³ / ₁₆	01 B 403	01 B 110M	306	407	18.6	1970	203.20	84.9	46.9	46.9	182	7	12.5	10.2
	02 B 403	02 B 110M	454	583	31.2	1820	228.60	100.0	57.2	57.2	202	9	13.5	16.0
4 ¹ / ₁₆	100 B 407	100 B 110M	279	426	22.2	2750	174.62	80.0	45.3	45.3	160	7	9.5	4.6
	01 B 407	01 B 110M	306	407	18.6	1970	203.20	84.9	46.9	46.9	182	7	12.5	10.2
	02 B 407	02 B 110M	454	583	31.2	1820	228.60	100.0	57.2	57.2	202	9	13.5	16.0
	03 B 407	03 B 110M	614	698	39.2	1640	266.70	147.0	87.3	87.3	232	11	30	36.0
4 ¹ / ₂	100 B 408	100 B 110M	279	426	22.2	2750	174.62	80.0	45.3	45.3	160	7	9.5	4.6
	01 B 408	01 B 110M	306	407	18.6	1970	203.20	84.9	46.9	46.9	182	7	12.5	10.2
	02 B 408	02 B 110M	454	583	31.2	1820	228.60	100.0	57.2	57.2	202	9	13.5	16.0
	03 B 408	03 B 110M	614	698	39.2	1640	266.70	147.0	87.3	87.3	232	11	30	36.0
4 ¹⁵ / ₁₆	100 B 415	100 B 130M	280	433	23.8	2480	203.20	85.0	46.9	46.9	180	7	11	7.4
	01 B 415	01 B 130M	355	484	22.2	1740	222.25	89.7	54.0	54.0	200	7	15	12.8
	02 B 415	02 B 130M	547	713	38.2	1600	254.00	114.3	63.5	63.5	224	10	15	20.0
	03 B 415	03 B 130M	706	852	49.0	1500	279.40	140.0	73.1	84.2	245	11	18	36.0
5	100 B 500	100 B 130M	280	433	23.8	2480	203.20	85.0	46.9	46.9	180	7	11	7.4
	01 B 500	01 B 130M	355	484	22.2	1740	222.25	89.7	54.0	54.0	200	7	15	12.8
	02 B 500	02 B 130M	547	713	38.2	1600	254.00	114.3	63.5	63.5	224	10	15	20.0
	03 B 500	03 B 130M	706	852	49.0	1500	279.40	140.0	73.1	84.2	245	11	18	36.0

CARTRIDGE

References (1)		Principal Dimensions				Mass (kg)
Cartridge for Felt seals	Cartridge for ATL seals	G (mm)	J (mm)	L (mm)	LI (mm)	
01 C 403	01 C 07	231.78	64	142	142	11.9
02 C 403	02 C 08	266.70	76	162	162	19
100 C 407	100 C 06	203.20	50	134	134	7.9
01 C 407	01 C 07	231.78	64	142	142	11.9
02 C 407	02 C 08	266.70	76	162	162	19
03 C 407	03 C 55	323.85	102	210	222	46
100 C 408	100 C 06	203.20	50	134	134	7.9
01 C 408	01 C 07	231.78	64	142	142	11.9
02 C 408	02 C 08	266.70	76	162	162	19
03 C 408	03 C 55	323.85	102	210	222	46
100 C 415	100 C 07	231.78	64	142	142	11
01 C 415	01 C 08	266.70	76	156	156	19.5
02 C 415	02 C 10	295.28	82	184	184	26
03 C 415	03 C 56	323.85	102	214	222	48
100 C 500	100 C 07	231.78	64	142	142	11
01 C 500	01 C 08	266.70	76	156	156	19.5
02 C 500	02 C 10	295.28	82	184	184	26
03 C 500	03 C 56	323.85	102	214	222	48

(1) Add 'EX' or 'GR' to reference for expansion type or fixed type respectively, e.g.: bearing: 01 B 500 EX
cartridge: 01 C 500 EX or 01 C 08 EX
Pedestals are common between expansion and fixed type units

(2) Total available axial movement given. Maximum offset from centreline half this amount.
"Usual" axial movement denotes maximum recommended range of running positions of EX bearing for optimum performance.
"Max." axial movement denotes available movement before fouling occurs in standard Cooper cartridge.

INCH-SIZE BEARINGS, CARTRIDGES AND PEDESTALS FROM 4³/₁₆" TO 5¹⁵/₁₆" BORE SIZE

2 Bolt

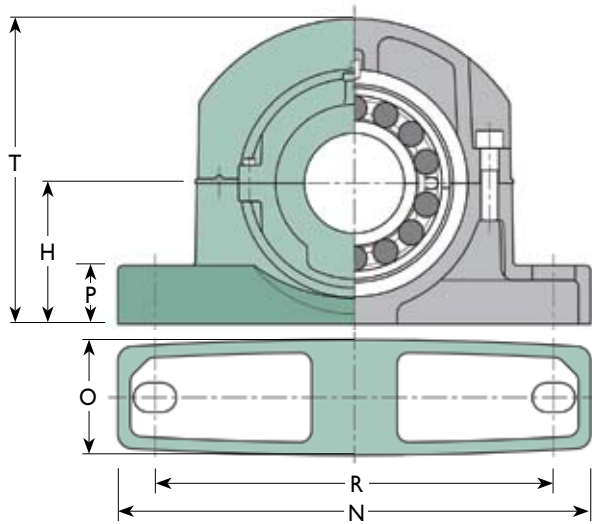

4 Bolt

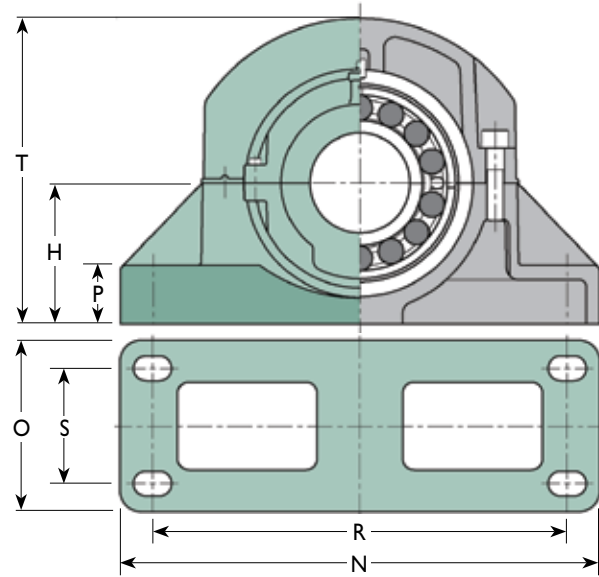

PEDESTAL

Reference	H (mm)	R		Ro (mm)	S (mm)	Bolts			N (mm)	O (mm)	P (mm)	T (mm)	Mass (Kg)	Shaft Diameter d (in)
		Min. (mm)	Max. (mm)			No.	Metric Size	Inch Size						
P07	143	374	410	-	-	2	M24	7/8"	466	120	60	314	20.6	4 ³ / ₁₆
P08	162	438	462	-	120	4	M24	7/8"	508	178	38	372	43.3	
P06	125	342	366	-	-	2	M24	7/8"	420	102	52	272	14.7	4 ⁷ / ₁₆
P07	143	374	410	-	-	2	M24	7/8"	466	120	60	314	20.6	
P08	162	438	462	-	120	4	M24	7/8"	508	178	38	372	43.3	
P55	197	446	470	-	88	4	M24	1"	534	166	38	425	69	
P06	125	342	366	-	-	2	M24	7/8"	420	102	52	272	14.7	4 ¹ / ₂
P07	143	374	410	-	-	2	M24	7/8"	466	120	60	314	20.6	
P08	162	438	462	-	120	4	M24	7/8"	508	178	38	372	43.3	
P55	197	446	470	-	88	4	M24	1"	534	166	38	425	69	
P07	143	374	410	-	-	2	M24	7/8"	466	120	60	314	20.6	4 ¹⁵ / ₁₆
P08	162	438	462	-	120	4	M24	7/8"	508	178	38	372	43.3	
P10	181	484	508	-	120	4	M24	7/8"	558	178	41	415	54	
P56	203	458	482	-	96	4	M24	1"	546	166	48	435	74	
P07	143	374	410	-	-	2	M24	7/8"	466	120	60	314	20.6	5
P08	162	438	462	-	120	4	M24	7/8"	508	178	38	372	43.3	
P10	181	484	508	-	120	4	M24	7/8"	558	178	41	415	54	
P56	203	458	482	-	96	4	M24	1"	546	166	48	435	74	

- (3) Maximum fillet radii of abutments:
 inner race: 2mm
 outer race: 100, 01 and 02 Series: 0.8mm
 03 Series: 2mm

- (4) Refer to data on equivalent metric bearing for vibration data, screw data and lubrication details.

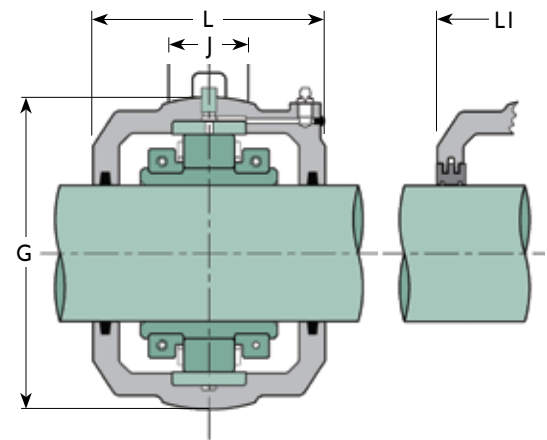
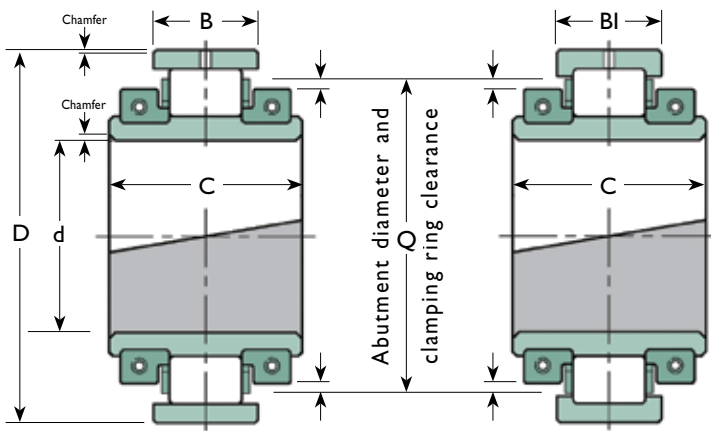

ROLLER BEARING

Shaft Diameter d (in)	Reference (1)	Equivalent Metric Bearing (4)	Bearing Ratings				Principal Dimensions					Axial Movement (2)		Mass (kg)
			Cr (kN)	Cor (kN)	Ca (kN)	Max. Speed (rpm)	D (mm)	C (mm)	B (mm)	BI (mm)	Q (mm)	Usual (mm)	Max. (mm)	
5 ³ / ₁₆	01 B 503	01 B 140M	394	542	25.8	1570	241.30	98.4	55.6	55.6	216	8	16	15.0
	02 B 503	02 B 140M	608	808	45.4	1450	273.05	117.5	66.7	66.7	240	10	15	24.0
5 ¹ / ₁₆	100 B 507	100 B 140M	331	520	30.5	2250	222.25	90.0	54.0	54.0	195	7	13	9.3
	01 B 507	01 B 140M	394	542	25.8	1570	241.30	98.4	55.6	55.6	216	8	16	15.0
	02 B 507	02 B 140M	608	808	45.4	1450	273.05	117.5	66.7	66.7	240	10	15	24.0
	03 B 507	03 B 140M	886	1069	58.8	1340	304.80	147.0	79.4	90.5	270	12	18	44.0
5 ¹ / ₂	100 B 508	100 B 140M	331	520	30.5	2250	222.25	90.0	54.0	54.0	195	7	13	9.3
	01 B 508	01 B 140M	394	542	25.8	1570	241.30	98.4	55.6	55.6	216	8	16	15.0
	02 B 508	02 B 140M	608	808	45.4	1450	273.05	117.5	66.7	66.7	240	10	15	24.0
	03 B 508	03 B 140M	886	1069	58.8	1340	304.80	147.0	79.4	90.5	270	12	18	44.0
5 ¹⁵ / ₁₆	100 B 515	100 B 150M	397	606	31.4	2060	241.30	90.0	55.6	55.6	215	8	15.5	10.4
	01 B 515	01 B 150M	428	616	29.4	1450	254.00	98.4	55.6	55.6	230	8	16	16.6
	02 B 515	02 B 150M	724	1005	52.4	1320	292.10	123.8	68.3	68.3	258	10	15	29.0
	03 B 515	03 B 150M	994	1213	69.4	1220	330.20	160.0	81.0	96.9	292	13	16	57.0
6	100 B 600	100 B 150M	397	606	31.4	2060	241.30	90.0	55.6	55.6	215	8	15.5	10.4
	01 B 600	01 B 150M	428	616	29.4	1450	254.00	98.4	55.6	55.6	230	8	16	16.6
	02 B 600	02 B 150M	724	1005	52.4	1320	292.10	123.8	68.3	68.3	258	10	15	29.0
	03 B 600	03 B 150M	994	1213	69.4	1220	330.20	160.0	81.0	96.9	292	13	16	57.0

CARTRIDGE

References (1)		Principal Dimensions				Mass (kg)
Cartridge for Felt seals	Cartridge for ATL seals	G (mm)	J (mm)	L (mm)	LI (mm)	
01 C 503	01 C 09	279.40	76	168	168	20.8
02 C 503	02 C 30	323.85	90	188	188	33
100 C 507	100 C 08	266.70	76	156	156	18.4
01 C 507	01 C 09	279.40	76	168	168	20.8
02 C 507	02 C 30	323.85	90	188	188	33
03 C 507	03 C 57	355.60	108	216	230	52
100 C 508	100 C 08	266.70	76	156	156	18.4
01 C 508	01 C 09	279.40	76	168	168	20.8
02 C 508	02 C 30	323.85	90	188	188	33
03 C 508	03 C 57	355.60	108	216	230	52
100 C 515	100 C 09	279.40	76	168	168	19.4
01 C 515	01 C 10	295.28	82	174	174	24.4
02 C 515	02 C 31	336.55	95	204	204	39
03 B 515	03 C 58	393.70	114	232	254	70
100 C 600	100 C 09	279.40	76	168	168	19.4
01 C 600	01 C 10	295.28	82	174	174	24.4
02 C 600	02 C 31	336.55	95	204	204	39
03 B 600	03 C 58	393.70	114	232	254	70

(1) Add 'EX' or 'GR' to reference for expansion type or fixed type respectively, e.g. bearing: 100 B 507 EX
cartridge: 100 C 507 EX or 100 C 08 EX
Pedestals are common between expansion and fixed type units

(2) Total available axial movement given. Maximum offset from centreline half this amount.
"Usual" axial movement denotes maximum recommended range of running positions of EX bearing for optimum performance.
"Max." axial movement denotes available movement before fouling occurs in standard Cooper cartridge.

INCH-SIZE BEARINGS, CARTRIDGES AND PEDESTALS FROM 5³/₁₆" TO 6" BORE SIZE

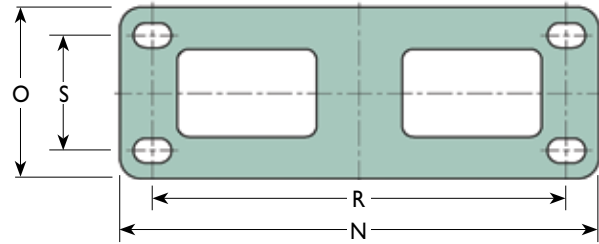
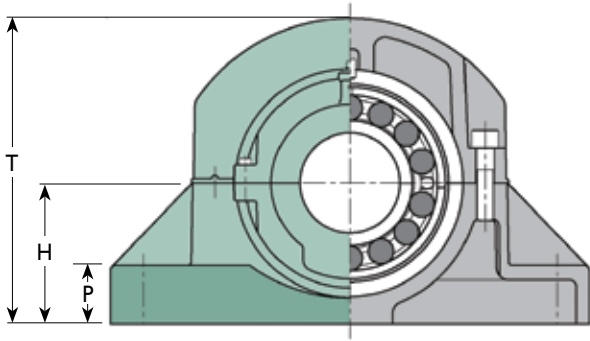

PEDESTAL

Reference	H (mm)	R		Ro (mm)	S (mm)	Bolts			N (mm)	O (mm)	P (mm)	T (mm)	Mass (Kg)	Shaft Diameter d (in)
		Min. (mm)	Max. (mm)			No.	Metric Size	Inch Size						
P09	181	470	494	-	120	4	M24	7/8"	558	178	41	405	52	5 ³ / ₁₆
P30	203	534	558	-	120	4	M24	1"	610	178	51	460	76	
P08	162	438	462	-	120	4	M24	7/8"	508	178	38	372	43.3	5 ⁷ / ₁₆
P09	181	470	494	-	120	4	M24	7/8"	558	178	41	405	52	
P30	203	534	558	-	120	4	M24	1"	610	178	51	460	76	
P57	229	494	534	-	102	4	M30	1 ¹ / ₄ "	622	178	54	485	97	
P08	162	438	462	-	120	4	M24	7/8"	508	178	38	372	43.3	5 ¹ / ₂
P09	181	470	494	-	120	4	M24	7/8"	558	178	41	405	52	
P30	203	534	558	-	120	4	M24	1"	610	178	51	460	76	
P57	229	494	534	-	102	4	M30	1 ¹ / ₄ "	622	178	54	485	97	
P09	181	470	494	-	120	4	M24	7/8"	558	178	41	405	52	5 ¹⁵ / ₁₆
P10	181	484	508	-	120	4	M24	7/8"	558	178	41	415	54	
P31	210	546	570	-	128	4	M24	1"	636	204	50	470	83	
P58	254	538	578	-	120	4	M30	1 ¹ / ₄ "	666	204	57	535	142	
P09	181	470	494	-	120	4	M24	7/8"	558	178	41	405	52	6
P10	181	484	508	-	120	4	M24	7/8"	558	178	41	415	54	
P31	210	546	570	-	128	4	M24	1"	636	204	50	470	83	
P58	254	538	578	-	120	4	M30	1 ¹ / ₄ "	666	204	57	535	142	

- (3) Maximum fillet radii of abutments:
 inner race: 2mm
 outer race: 100, 01 and 02 Series: 0.8mm
 03 Series: 2mm

- (4) Refer to data on equivalent metric bearing for vibration data, screw data and lubrication details.

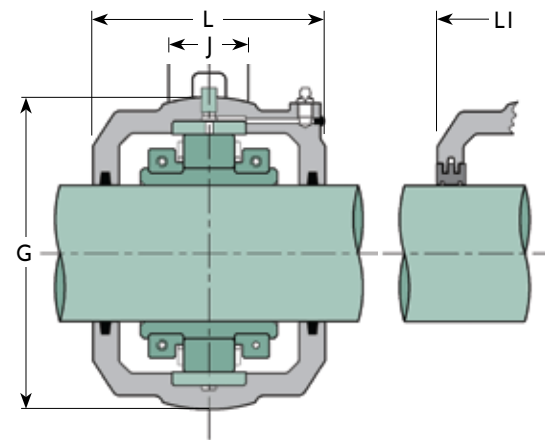
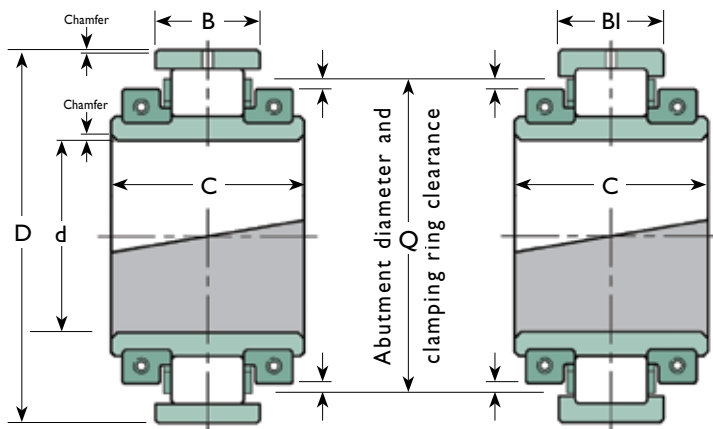

ROLLER BEARING

Shaft Diameter d (in)	Reference (1)	Equivalent Metric Bearing (4)	Bearing Ratings				Principal Dimensions					Axial Movement (2)		Mass (kg)
			Cr (kN)	Cor (kN)	Ca (kN)	Max. Speed (rpm)	D (mm)	C (mm)	B (mm)	BI (mm)	Q (mm)	Usual (mm)	Max. (mm)	
6 ¹ / ₁₆	01 B 607	01 B 160M	487	715	33.0	1320	273.05	109.0	60.3	60.3	248	8	18	21.0
	02 B 607	02 B 160M	762	1033	61.4	1200	317.50	140.0	83.3	83.3	280	11	25	39.0
	03 B 607	03 B 160M	1156	1564	79.2	1110	355.60	171.0	103.2	103.2	308	14	31	72.0
6 ¹ / ₂	01 B 608	01 B 160M	487	715	33.0	1320	273.05	109.0	60.3	60.3	248	8	18	21.0
	02 B 608	02 B 160M	762	1033	61.4	1200	317.50	140.0	83.3	83.3	280	11	25	39.0
	03 B 608	03 B 160M	1156	1564	79.2	1110	355.60	171.0	103.2	103.2	308	14	31	72.0
6 ¹⁵ / ₁₆	01 B 615	01 B 180M	524	801	36.4	1220	285.75	109.0	55.5	55.5	260	8	13.5	23.0
	02 B 615	02 B 180M	840	1191	71.2	1120	330.20	140.0	83.3	83.3	294	11	25	45.0
	03 B 615	03 B 180M	1242	1704	89.0	1030	374.65	178.0	92.1	108.8	326	15	16	79.0
7	01 B 700	01 B 180M	524	801	36.4	1220	285.75	109.0	55.5	55.5	260	8	13.5	23.0
	02 B 700	02 B 180M	840	1191	71.2	1120	330.20	140.0	83.3	83.3	294	11	25	45.0
	03 B 700	03 B 180M	1242	1704	89.0	1030	374.65	178.0	92.1	108.8	326	15	16	79.0
7 ¹⁵ / ₁₆	01 B 715	01 B 200M	555	893	41.0	1070	311.15	109.0	60.3	60.3	285	8	18	25.0
	02 B 715	02 B 200M	998	1457	80.0	960	368.30	156.0	90.5	90.5	328	13	26	59.0
	03 B 715	03 B 200M	1451	2022	99.6	880	419.10	191.0	97.7	118.3	366	16	16	105

CARTRIDGE

References (1)		Principal Dimensions					Mass (kg)
Cartridge for Felt seals	Cartridge for ATL seals	G (mm)	J (mm)	L (mm)	LI (mm)		
01 C 607	01 C 11	311.15	76	172	192	30	
02 C 607	02 C 32	368.30	95	206	232	56	
03 C 607	03 C 59	422.30	120	244	268	81	
01 C 608	01 C 11	311.15	76	172	192	30	
02 C 608	02 C 32	368.30	95	206	232	56	
03 C 608	03 C 59	422.30	120	244	268	81	
01 C 615	01 C 12	323.85	70	172	200	31	
02 C 615	02 C 33	381.00	95	222	242	66	
03 C 615	03 C 60	431.80	132	254	284	87	
01 C 700	01 C 12	323.85	70	172	200	31	
02 C 700	02 C 33	381.00	95	222	242	66	
03 C 700	03 C 60	431.80	132	254	284	87	
01 C 715	01 C 13	358.78	86	172	200	41	
02 C 715	02 C 34	425.50	105	235	258	84	
03 C 715	03 C 61	489.00	146	270	300	109	

(1) Add 'EX' or 'GR' to reference for expansion type or fixed type respectively,
e.g. bearing: 01 B 607 EX
cartridge: 01 C 607 EX or 01 C 11 EX
Pedestals are common between expansion and fixed type units

(2) Total available axial movement given. Maximum offset from centreline half this amount.
"Usual" axial movement denotes maximum recommended range of running positions of EX bearing for optimum performance.
"Max." axial movement denotes available movement before fouling occurs in standard Cooper cartridge.

INCH-SIZE BEARINGS, CARTRIDGES AND PEDESTALS FROM 6⁷/₁₆" TO 7¹⁵/₁₆" BORE SIZE

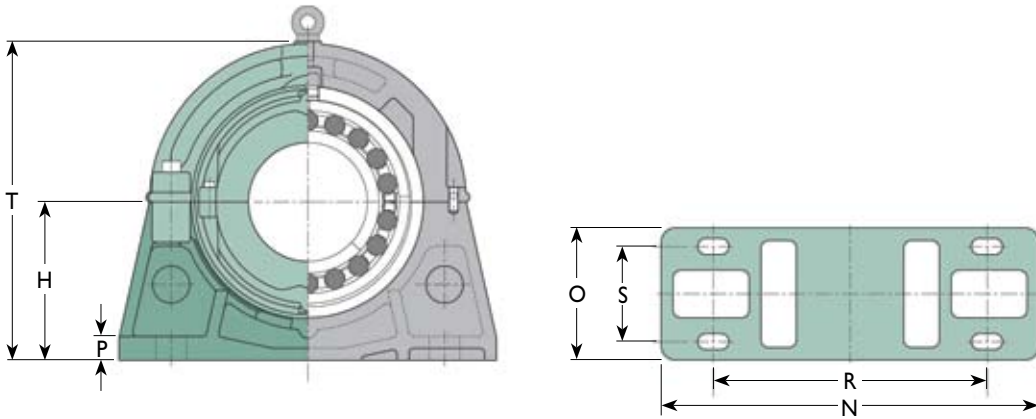

PEDESTAL

Reference	H (mm)	R		Ro (mm)	S (mm)	Bolts			N (mm)	O (mm)	P (mm)	T (mm)	Mass (Kg)	Shaft Diameter d (in)
		Min. (mm)	Max. (mm)			No.	Metric Size	Inch Size						
P11	213	356	380	-	114	4	M24	1"	508	178	32	430	53	6 ⁷ / ₁₆
P32	267	428	468	-	172	4	M30	1 ¹ / ₄ "	596	242	44	535	106	
P59	267	608	648	-	140	4	M30	1 ¹ / ₄ "	736	228	60	570	162	
P11	213	356	380	-	114	4	M24	1"	508	178	32	430	53	6 ¹ / ₂
P32	267	428	468	-	172	4	M30	1 ¹ / ₄ "	596	242	44	535	106	
P59	267	608	648	-	140	4	M30	1 ¹ / ₄ "	736	228	60	570	162	
P12	235	376	400	-	128	4	M24	1"	534	190	35	470	63	6 ¹⁵ / ₁₆
P33	273	438	478	-	166	4	M30	1 ¹ / ₄ "	636	242	44	545	116	
P60	279	616	656	-	152	4	M30	1 ¹ / ₄ "	762	254	64	580	172	
P12	235	376	400	-	128	4	M24	1"	534	190	35	470	63	7
P33	273	438	478	-	166	4	M30	1 ¹ / ₄ "	636	242	44	545	116	
P60	279	616	656	-	152	4	M30	1 ¹ / ₄ "	762	254	64	580	172	
P13	248	410	434	-	140	4	M24	1"	572	204	38	495	83	7 ¹⁵ / ₁₆
P34	305	488	528	-	190	4	M30	1 ¹ / ₄ "	686	266	50	610	145	
P61	311	616	656	-	172	4	M36	1 ¹ / ₂ "	838	266	67	655	223	

(3) Maximum fillet radii of abutments:
inner race: 2.3mm
outer race: 2mm

(4) Refer to data on equivalent metric bearing for vibration data, screw data and lubrication details.

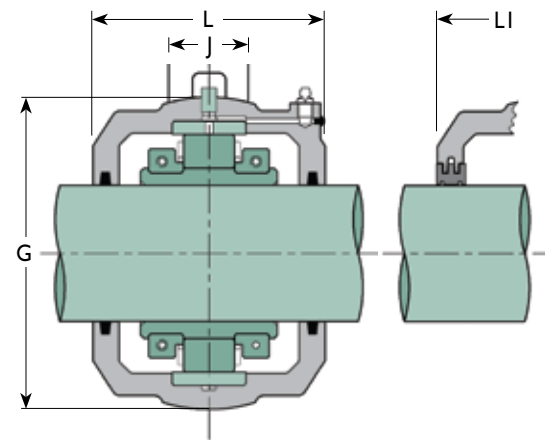
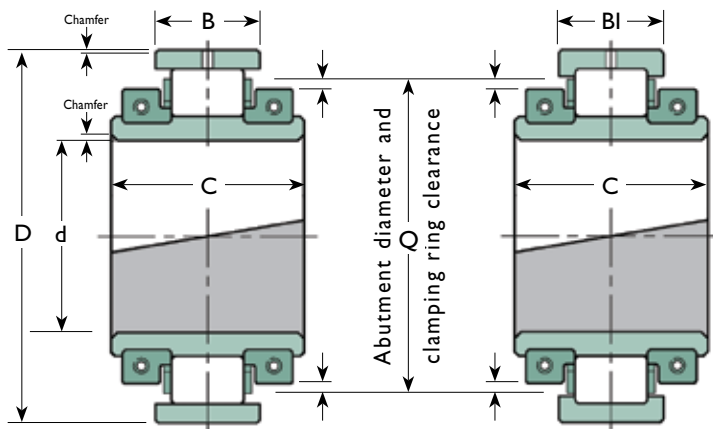

ROLLER BEARING

Shaft Diameter d (in)	Reference (1)	Equivalent Metric Bearing (4)	Bearing Ratings				Principal Dimensions					Axial Movement (2)		Mass (kg)
			Cr (kN)	Cor (kN)	Ca (kN)	Max. Speed (rpm)	D (mm)	C (mm)	B (mm)	BI (mm)	Q (mm)	Usual (mm)	Max. (mm)	
8	01 B 800	01 B 200M	555	893	41.0	1070	311.15	109.0	60.3	60.3	285	8	18	25.0
	02 B 800	02 B 200M	998	1457	80.0	960	368.30	156.0	90.5	90.5	328	13	26	59.0
	03 B 800	03 B 200M	1451	2022	99.6	880	419.10	191.0	97.7	118.3	366	16	16	105
9	01 B 900	01 B 220M	600	980	49.0	930	342.90	115.0	63.5	63.5	315	8	19	32
	02 B 900	02 B 220M	1082	1662	89.8	850	393.70	163.0	90.5	90.5	354	13	26	68
	03 B 900	03 B 220M	1586	2163	109.4	760	469.90	212.0	109.6	131.8	410	18	18	145
10	01 B 1000	01 B 250M	675	1182	57.8	820	374.65	122.0	66.7	66.7	344	9	22	40
	02 B 1000	02 B 250M	1149	1756	98.8	750	431.80	170.0	96.8	96.8	388	13	29	77
	03 B 1000	03 B 250M	1778	2551	131	700	482.60	211.0	105.6	124.6	430	18	33	150
11	01 B 1100	01 B 280M	769	1330	66.8	730	406.40	128.0	69.0	69.0	375	10	20	50
	02 B 1100	02 B 280M	1367	2145	114	670	463.55	186.0	101.6	101.6	420	14	29	86
	03X B 1100	03X B 280M	1956	2960	153	620	520.70	231.0	131.8	131.8	462	18	40	197
	03E B 1100	03E B 280M	2105	3233	153	620	495.30	244.0	139.7	139.7	452	20	34	182
12	01 B 1200	01 B 300M	806	1452	78.2	650	438.15	143.0	74.6	74.6	404	10	25	60
	02 B 1200	02 B 300M	1467	2409	129	610	495.30	193.0	103.2	103.2	448	14	30	123
	03 B 1200	03 B 300M	2156	3312	174	560	558.80	244.0	139.7	139.7	496	19	43	238

CARTRIDGE

References (1)		Principal Dimensions				Mass (kg)
Cartridge for Felt seals	Cartridge for ATL seals	G (mm)	J (mm)	L (mm)	LI (mm)	
01 C 800	01 C 13	358.78	86	172	200	41
02 C 800	02 C 34	425.50	105	235	258	84
03 C 800	03 C 61	489.00	146	270	300	109
01 C 900	01 C 14	387.35	82	178	216	46
02 C 900	02 C 35	457.20	110	242	274	98
03 C 900	03 C 62	546.10	165	298	334	155
01 C 1000	01 C 15	419.10	90	188	222	58
02 C 1000	02 C 36	495.30	118	248	280	105
03 C 1000	03 C 63	558.80	165	298	334	161
01 C 1100	01 C 16	454.00	95	204	232	70
02 C 1100	02 C 37	527.10	130	264	300	131
03X C 1100	03X C 64	596.90	165	324	352	200
03E C 1100	03E C 83	571.50	165	356	356	204
01 C 1200	01 C 17	489.00	98	216	248	86
02 C 1200	02 C 38	552.50	128	268	306	129
03 C 1200	03 C 65	641.40	165	346	370	239

(1) Add 'EX' or 'GR' to reference for expansion type or fixed type respectively, e.g.: bearing: 01 B 900 EX
cartridge: 01 C 900 EX or 01 C 14 EX
Pedestals are common between expansion and fixed type units

(2) Total available axial movement given. Maximum offset from centreline half this amount.
"Usual" axial movement denotes maximum recommended range of running positions of EX bearing for optimum performance.
"Max." axial movement denotes available movement before fouling occurs in standard Cooper cartridge.

INCH-SIZE BEARINGS, CARTRIDGES AND PEDESTALS FROM 8" TO 12" BORE SIZE

4 Bolt

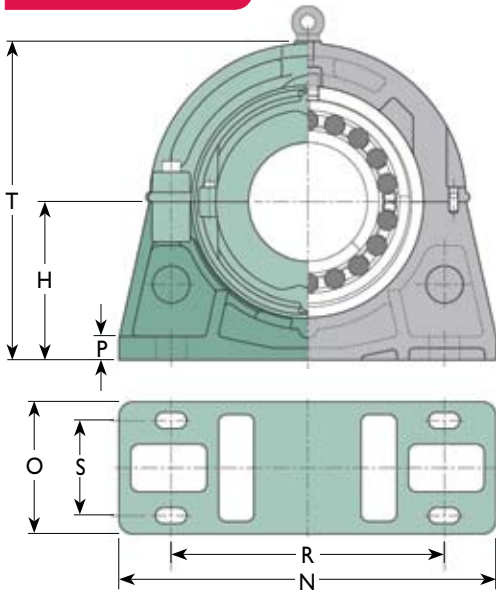

8 Bolt

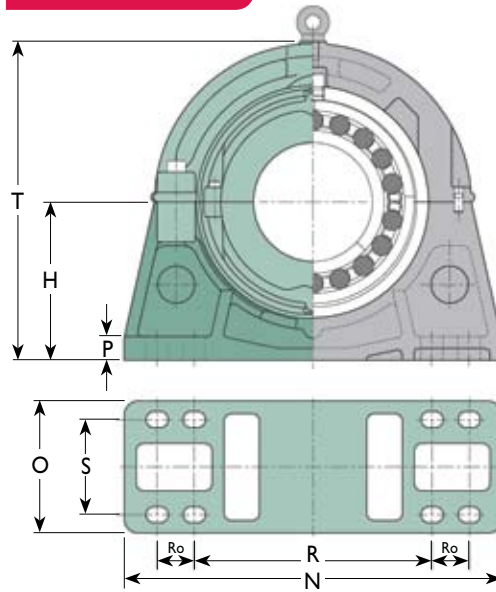

PEDESTAL

Reference	H (mm)	R		Ro (mm)	S (mm)	Bolts			N (mm)	O (mm)	P (mm)	T (mm)	Mass (Kg)	Shaft Diameter d (in)
		Min. (mm)	Max. (mm)			No.	Metric Size	Inch Size						
P13	248	410	434	-	140	4	M24	1"	572	204	38	495	83	
P34	305	488	528	-	190	4	M30	1¼"	686	266	50	610	145	8
P61	311	616	656	-	172	4	M36	1½"	838	266	67	655	223	
P14	270	440	480	-	140	4	M30	1¼"	636	216	40	540	90	
P35	324	530	570	-	190	4	M36	1½"	750	280	50	650	179	9
P62	349	716	756	-	178	4	M42	1¾"	952	280	76	730	309	
P15	292	482	522	-	140	4	M30	1¼"	686	228	44	585	114	
P36	356	576	616	-	204	4	M36	1½"	812	292	54	710	212	10
P63	394	650	690	-	304	4	M42	1¾"	914	406	76	790	392	
P16	311	514	554	-	140	4	M30	1¼"	724	228	48	620	142	
P37	378	514	554	101	254	8	M30	1¼"	914	330	60	760	292	11
P64	425	590	630	101	318	8	M36	1½"	1028	406	76	850	495	
P83	368	482	522	120	178	8	M36	1½"	940	280	70	785	205	
P17	343	564	604	-	178	4	M30	1¼"	762	254	50	685	169	
P38	394	546	586	101	254	8	M30	1¼"	958	330	60	790	330	12
P65	457	654	694	101	330	8	M36	1½"	1092	420	76	915	586	

(3) Maximum fillet radii of abutments:
inner race: 2.3mm
outer race: 2mm

(4) Refer to data on equivalent metric bearing for vibration data, screw data and lubrication details.

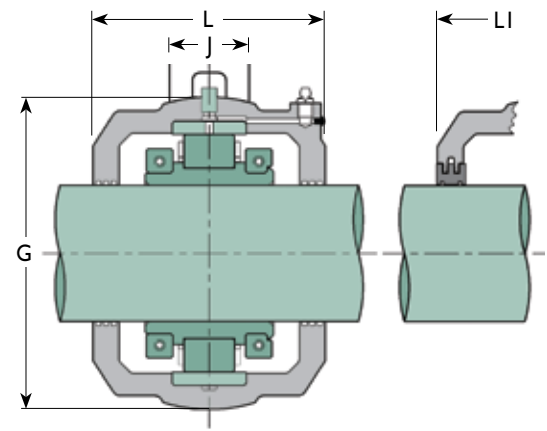
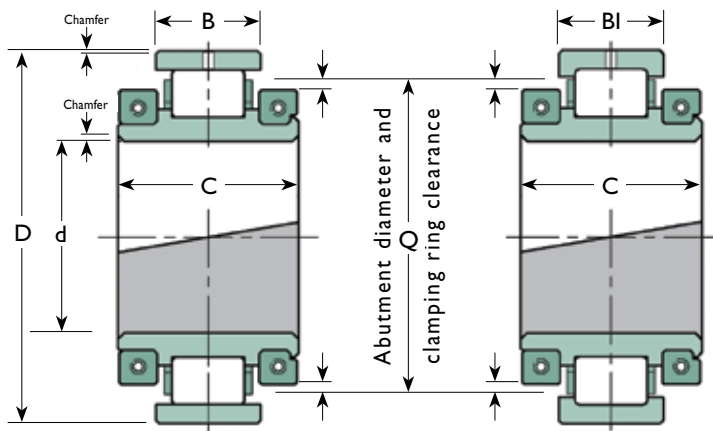

ROLLER BEARING

Shaft Diameter d (in)	Reference (1)	Equivalent Metric Bearing (4)	Bearing Ratings				Principal Dimensions					Axial Movement (2)		Mass (kg)
			Cr (kN)	Cor (kN)	Ca (kN)	Max. Speed (rpm)	D (mm)	C (mm)	B (mm)	BI (mm)	Q (mm)	Usual (mm)	Max. (mm)	
13	01 B 1300	01 B 320M	894	1638	89.0	590	463.55	136.0	74.6	74.6	432	10	23	72
	02 B 1300	02 B 320M	1570	2622	144	550	527.05	192.0	106.4	106.4	478	15	30	150
	03 B 1300	03 B 320M	2529	3795	199	500	622.30	272.0	160.4	160.4	550	22	48	327
14	01 B 1400	01 B 340M	935	1774	99.6	540	488.95	136.0	74.6	74.6	456	10	23	78
	02 B 1400	02 B 340M	1744	2940	159	500	565.15	200.0	115.9	115.9	514	16	35	182
	03E B 1400	03E B 340M	2750	4392	214	460	615.95	279.0	158.0	158.0	556	22	44	318
15	01 B 1500	01 B 380M	1005	1925	110	500	520.70	140.0	76.2	76.2	486	10	23	86
	02 B 1500	02 B 380M	1862	3254	174	460	584.20	200.0	111.1	111.1	536	16	30	186
	03 B 1500	03 B 380M	3019	4800	251	420	685.80	292.0	166.7	166.7	610	23	50	431
16	01 B 1600	01 B 400M	1048	2071	116	460	546.10	140.0	76.2	76.2	512	10	23	95
	02 B 1600	02 B 400M	1948	3438	188	430	615.95	200.0	115.9	115.9	566	16	33	209
17	01 B 1700	01 B 420M	1089	2218	121	430	571.50	140.0	76.2	76.2	538	10	22	104
	02 B 1700	02 B 420M	2069	3702	202	400	647.70	200.0	119.1	119.1	596	17	33	241
	03E B 1700	03E B 420M	3474	6006	276	360	700.00	284.0	160.0	160.0	640	23	42	395
18	01 B 1800	01 B 460M	1129	2366	127	410	596.90	140.0	76.2	76.2	562	10	22	114
	02 B 1800	02 B 460M	2195	4057	216	380	666.75	200.0	115.9	115.9	618	17	30	250
	03E B 1800	03E B 460M	3650	6156	302	340	740.00	294.0	170.0	170.0	680	24	46	431

CARTRIDGE

References (1)		Principal Dimensions				Mass (kg)
Cartridge for Felt seals	Cartridge for ATL seals	G (mm)	J (mm)	L (mm)	LI (mm)	
01 C 1300	01 C 18	520.70	95	260	272	106
02 C 1300	02 C 39	587.40	128	298	330	172
03 C 1300	03 C 66	717.60	170	368	418	273
01 C 1400	01 C 19	546.10	98	260	272	117
02 C 1400	02 C 40	628.70	146	305	342	186
03E C 1400	03E C 86	704.90	196	432	432	385
01 C 1500	01 C 20	571.50	98	260	280	126
02 C 1500	02 C 41	647.70	146	305	342	209
03 C 1500	03 C 68	774.70	202	400	438	399
01 C 1600	01 C 21	603.30	102	280	286	141
02 C 1600	02 C 42	685.80	146	324	350	254
01 C 1700	01 C 22	628.70	102	292	298	150
02 C 1700	02 C 43	717.60	146	324	356	264
03E C 1700	03E C 89	788.00	200	440	442	408
01 C 1800	01 C 23	650.90	108	304	310	151
02 C 1800	02 C 44	733.40	146	324	356	265
03E C 1800	03E C 90	840.00	200	450	450	454

(1) Add 'EX' or 'GR' to reference for expansion type or fixed type respectively, e.g.: bearing: 01 B 1500 EX
cartridge: 01 C 1500 EX or 01 C 20 EX
Pedestals are common between expansion and fixed type units

(2) Total available axial movement given. Maximum offset from centreline half this amount.
"Usual" axial movement denotes maximum recommended range of running positions of EX bearing for optimum performance.
"Max." axial movement denotes available movement before fouling occurs in standard Cooper cartridge.

INCH-SIZE BEARINGS, CARTRIDGES AND PEDESTALS FROM 13" TO 18" BORE SIZE

4 Bolt

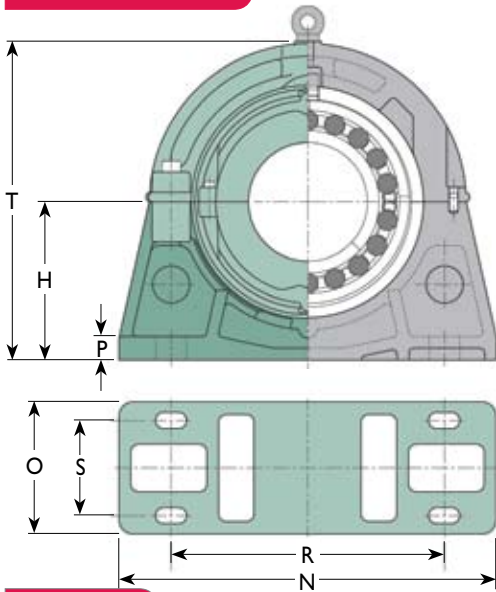

8 Bolt

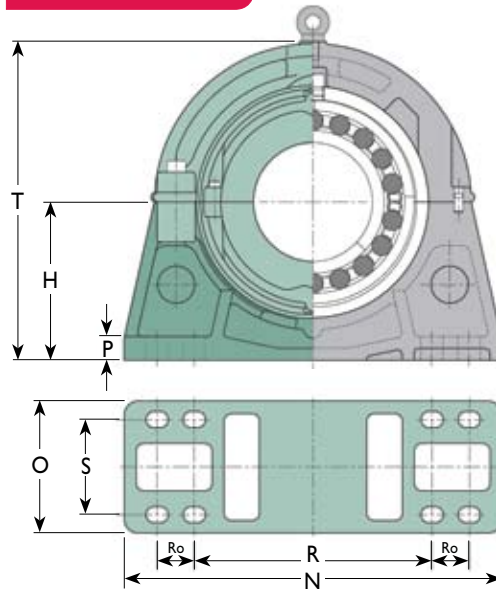

PEDESTAL

Reference	H (mm)	R		Ro (mm)	S (mm)	Bolts			N (mm)	O (mm)	P (mm)	T (mm)	Mass (Kg)	Shaft Diameter d (in)
		Min. (mm)	Max. (mm)			No.	Metric Size	Inch Size						
P18	368	602	642	-	178	4	M36	1½"	812	254	54	735	196	13
P39	419	590	630	101	210	8	M30	1¼"	1016	292	64	840	383	
P66	518	742	782	108	266	8	M36	1½"	1194	356	80	1035	655	
P19	387	634	674	-	166	4	M36	1½"	850	254	57	775	213	14
P40	451	640	680	102	280	8	M36	1½"	1092	368	67	900	429	
P86	470	634	686	134	190	8	M42	1¾"	1220	318	82	1000	464	
P20	397	656	696	-	166	4	M36	1½"	902	254	60	795	288	15
P41	464	662	702	102	280	8	M36	1½"	1092	368	67	925	445	
P68	559	780	832	115	292	8	M42	1¾"	1270	394	92	1120	859	
P21	432	704	744	-	166	4	M36	1½"	940	254	67	865	309	16
P42	495	710	750	102	280	8	M36	1½"	1168	368	70	990	537	
P22	445	736	776	-	166	4	M36	1½"	966	254	67	890	316	17
P43	514	748	788	102	280	8	M36	1½"	1194	368	70	1030	564	
P89	508	664	716	150	210	8	M48	2"	1270	360	90	1075	482	
P23	464	768	808	-	190	4	M42	1¾"	1042	280	70	925	370	18
P44	533	768	808	104	280	8	M36	1½"	1244	368	73	1070	564	
P90	550	754	806	150	220	8	M48	2"	1370	380	95	1165	705	

(3) Maximum fillet radii of abutments:
inner race: 2.3mm
outer race: 2mm

(4) Refer to data on equivalent metric bearing for vibration data, screw data and lubrication details.

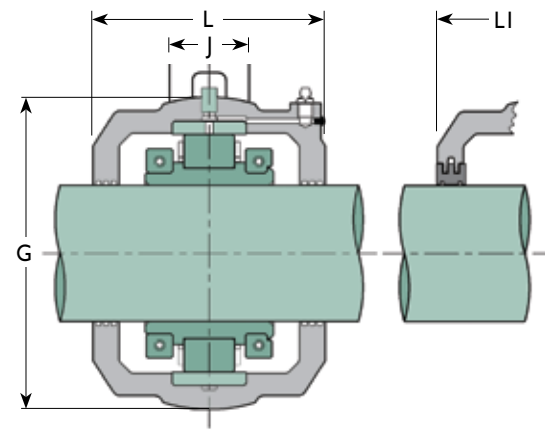
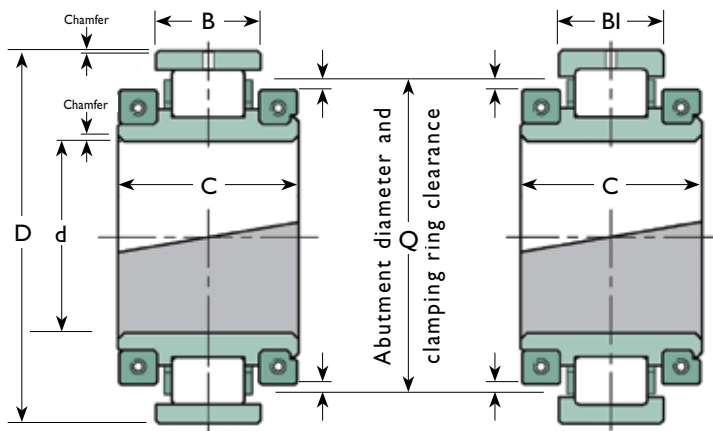

ROLLER BEARING

Shaft Diameter d (in)	Reference (1)	Equivalent Metric Bearing (4)	Bearing Ratings				Principal Dimensions					Axial Movement (2)		Mass (kg)
			Cr (kN)	Cor (kN)	Ca (kN)	Max. Speed (rpm)	D (mm)	C (mm)	B (mm)	BI (mm)	Q (mm)	Usual (mm)	Max. (mm)	
19	01 B 1900	01 B 480M	1169	2433	133	380	628.65	144.0	81.0	81.0	594	11	24	128
	02 B 1900	02 B 480M	2313	4419	230	360	698.50	223.0	119.1	119.1	648	17	33	263
20	01 B 2000	01 B 500M	1213	2593	138	360	654.05	168.0	80.2	80.2	618	11	23	136
	02 B 2000	02 B 500M	2430	4776	244	340	717.55	226.0	115.9	115.9	670	17	30	272
	03 B 2000	03 B 500M	4087	7042	347	310	850.90	300.0	187.4	187.4	765	26	56	730
21	01 B 2100	01 B 530M	1253	2755	141	340	692.15	168.0	81.0	81.0	650	11	23	164
	02 B 2100	02 B 530M	2658	5137	258	330	762.00	229.0	119.1	119.1	710	18	27	309
22	01 B 2200	01 B 560M	1294	2916	142	330	717.55	168.0	81.0	81.0	675	11	23	178
	02 B 2200	02 B 560M	2790	5556	272	310	793.75	233.0	122.2	122.2	738	18	30	336
	03E B 2200	03E B 560M	4669	8511	383	280	863.60	310.0	196.9	196.9	800	28	56	635
23	01 B 2300	01 B 580M	1387	3138	144	310	749.30	172.0	84.1	84.1	706	11	25	195
	02 B 2300	02 B 580M	2336	4836	227	300	812.80	232.0	119.1	119.1	754	16	37	340
	03E B 2300	03E B 600M	4887	9130	400	270	890.00	310.0	184.0	184.0	826	27	47	680
24	01 B 2400	01 B 600M	1431	3311	147	300	774.70	172.0	84.1	84.1	732	11	25	210
	02 B 2400	02 B 600M	2905	5992	300	290	838.20	214.0	119.1	119.1	786	18	27	381

CARTRIDGE

References (1)		Principal Dimensions				Mass (kg)
Cartridge for Felt seals	Cartridge for ATL seals	G (mm)	J (mm)	L (mm)	LI (mm)	
01 C 1900	01 C 24	682.60	108	304	324	162
02 C 1900	02 C 45	762.00	146	338	374	272
01 C 2000	01 C 25	717.60	114	304	330	192
02 C 2000	02 C 46	787.40	146	350	374	323
03 C 2000	03 C 94	958.90	204	495	508	770
01 C 2100	01 C 26	755.70	114	330	336	226
02 C 2100	02 C 47	831.90	150	350	374	351
01 C 2200	01 C 27	781.10	114	336	342	252
02 C 2200	02 C 48	866.80	152	356	380	379
03E C 2200	03E C 94	958.90	204	490	490	671
01 C 2300	01 C 28	816.00	120	342	348	273
02 C 2300	02 C 49	882.70	152	356	380	386
03E C 2300	03E C 95	990.00	204	490	490	720
01 C 2400	01 C 29	841.40	120	342	348	290
02 C 2400	02 C 50	914.40	152	388	394	454

(1) Add 'EX' or 'GR' to reference for expansion type or fixed type respectively, e.g.: bearing: 01 B 2000 EX
cartridge: 01 C 2000 EX or 01 C 25 EX
Pedestals are common between expansion and fixed type units

(2) Total available axial movement given. Maximum offset from centreline half this amount.
"Usual" axial movement denotes maximum recommended range of running positions of EX bearing for optimum performance.
"Max." axial movement denotes available movement before fouling occurs in standard Cooper cartridge.

INCH-SIZE BEARINGS, CARTRIDGES AND PEDESTALS FROM 19" TO 24" BORE SIZE

4 Bolt

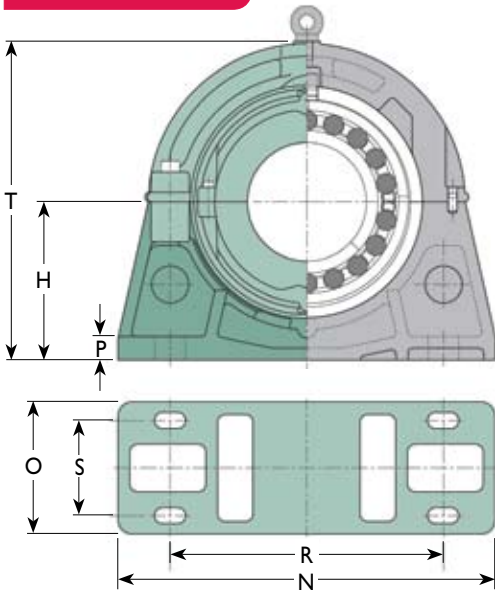

8 Bolt

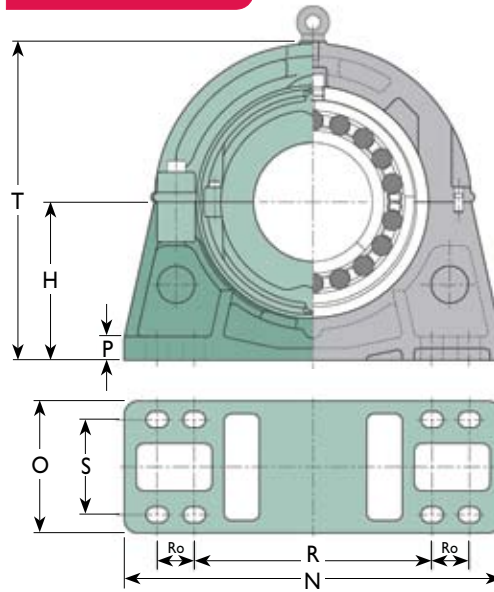

PEDESTAL

Reference	H (mm)	R		Ro (mm)	S (mm)	Bolts			N (mm)	O (mm)	P (mm)	T (mm)	Mass (Kg)	Shaft Diameter d (in)
		Min. (mm)	Max. (mm)			No.	Metric Size	Inch Size						
P24	483	796	836	-	188	4	M42	1 3/4"	1092	304	73	965	402	19
P45	552	792	832	115	280	8	M36	1 1/2"	1270	368	76	1110	690	
P25	489	824	864	-	216	4	M42	1 3/4"	1092	304	76	980	402	20
P46	572	824	864	115	280	8	M36	1 1/2"	1296	368	80	1145	677	
P94	622	914	966	165	242	8	M56	2 1/4"	1600	406	102	1340	1000	21
P26	533	884	924	-	206	4	M42	1 3/4"	1194	304	80	1065	495	
P47	591	870	910	114	280	8	M36	1 1/2"	1398	368	83	1180	905	
P27	552	916	956	-	206	4	M42	1 3/4"	1220	304	83	1110	570	22
P48	616	904	956	114	280	8	M42	1 3/4"	1422	382	86	1230	965	
P94	622	914	966	165	242	8	M56	2 1/4"	1600	406	102	1340	1000	23
P28	578	857	896	102	220	8	M36	1 1/2"	1346	304	90	1156	630	
P49	635	932	984	115	280	8	M42	1 3/4"	1448	382	90	1270	1000	
P95	622	914	966	165	242	8	M56	2 1/4"	1600	406	102	1340	930	24
P29	597	888	928	105	220	8	M36	1 1/2"	1372	304	90	1200	630	
P50	673	984	1036	114	280	8	M42	1 3/4"	1524	382	92	1345	1050	

(3) Maximum fillet radii of abutments:
inner race: 2.3mm
outer race: 2mm

(4) Refer to data on equivalent metric bearing for vibration data, screw data and lubrication details.

Pedestals for Standard Type Bearings and Cartridges

Cooper SNC500, SAFC500 and SDC3100 Series pedestals are designed for use where interchangeability with SN500, SAF500 and SD3100 Series pillow block units is required, respectively. They may be used to economically replace existing solid bearings, or may be incorporated into new machinery where the envelope dimensions of these units are desirable.

The Cooper pedestals have bolt hole spacings and heights to centres corresponding to the equivalent industry standard units for solid bearings. However the footprint, overall pedestal height and length on shaft may differ and should be checked against the available space.

Cooper SNC500, SAFC500 and SDC3100 pedestals are designed to incorporate Cooper bearings housed in cartridges (refer to page 28), which gives these units the benefit of superior Cooper sealing and the option of many different seal types.

The tables on the following pages list the Cooper pedestals with the bearing and cartridge unit of the same bore size as the solid bearing that is commonly found mounted in the equivalent pillow block unit on a parallel shaft with an adaptor sleeve. These pedestals may also be used with alternative sizes of Cooper bearing. Where the bearing and cartridge unit listed with the Cooper pedestal on the following pages is used in the same size of standard Cooper pedestal as another size of Cooper bearing and cartridge, generally this alternative size of bearing and cartridge can be used in the same Cooper SNC500, SAFC500 or SDC3100 Series pedestal.

For example:

01E BC SNC513 60M incorporates an 01E B 60M bearing and an 01 C 60M cartridge.

01 C 60M is usually housed in a P03 pedestal (by reference to pages 30 and 31)

Other bearings and cartridges are also housed in P03 pedestals, including:

100 C 75M
01 C 65M
02 C 50M

All of these can alternatively be housed in a Cooper SNC513 pedestal.

SNC500 pedestals are manufactured from grey iron as standard. SAFC500 and SDC3100 pedestals are manufactured from ductile iron as standard.

The permissible loading on these pedestals is as for standard grey iron pedestals, as described on page 29. Where special dispensation to load outside the envelope specified on page 29 has been given for standard pedestals, this does not necessarily apply to SNC500, SAFC500 or SDC3100 series pedestals. Please consult our technical department if other loading conditions are required to be met.

Heavy Duty 08 Series SDC Pedestal Units

The heavy duty Cooper 08SDC Series pillow blocks housing Cooper 08 Series bearings are intended to interchange with SD3100 Series in applications where higher capacity is required than the Cooper 01 Series, but the SDC3100 envelope is too restrictive to incorporate a standard Cooper 02 Series bearing and cartridge in a compatible pedestal.

The Cooper 08 Series is based on the Cooper 02 Series but has a spherically-backed outer race mounted directly into the pedestal. The 08 Series is completely split to the shaft as per the 02 Series. The two halves of the outer race are screwed together and have alignment features to ensure that an accurate roller path is maintained across the outer race joint.

The 08 Series bearings for mounting in 08SDC Series pedestals is produced in fixed ('GR') and expansion ('EX') versions. The GR version uses lips on the outer race and on the inner race clamping rings to provide axial location to the rollers. The EX version uses a lipped outer race and plain inner race which allows the rollers to spiral across it with virtually no resistance to axial movement. This is similar to the EXILOG configuration (see page 6), except that the available axial movement is not necessarily as great and the outer race has a spherical outside diameter:

The pedestal ends are closed by removable end covers. These allow access to the seals without disturbing the bearing, and allow access to the clamping ring screws for maintenance or bearing change-out purposes even if the shaft has stopped with the inner race in an inconvenient position and cannot be turned. The end covers are interchangeable between pedestals to allow change to different seal type if required, or replacement in the event of damage.

The maximum misalignment between the shaft and pedestal axes is less than with Cooper 01 or 02 Series based units as the seals do not move with the bearing. However, the flexible packing seal which will be found suitable for many applications is designed to allow a reasonable amount of misalignment by virtue of its large section and flexible core. Additional clearance is present in the TL seal version compared to our standard TL seals.

The three standard sealing options available with the 08SDC Series are illustrated on page 73.

SN COMPATIBLE PEDESTALS

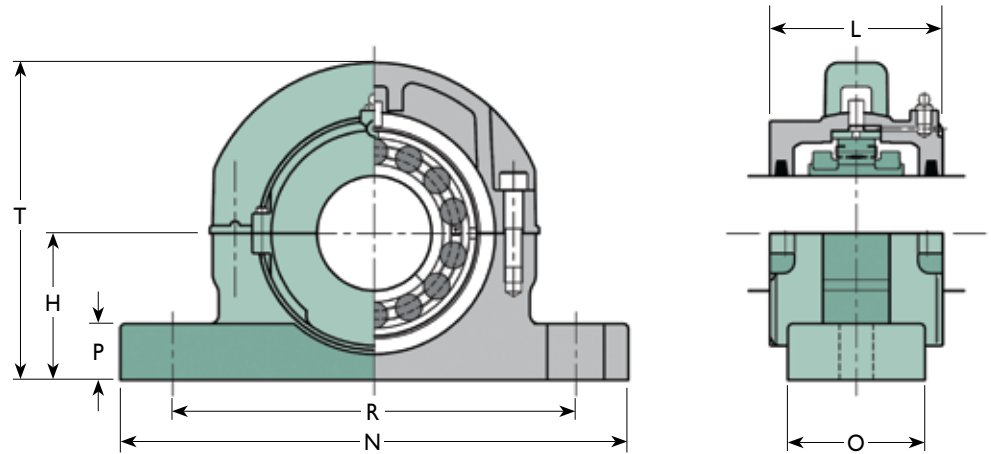

Shaft Diameter d (mm)	Bearing Reference(1)	Reference(1) (pedestal only)	H (mm)	R		Bolt size	N (mm)	O (mm)	P (mm)	T (mm)	L(2) (mm)	Pedestal Mass (kg)
				Min. (mm)	Max. (mm)							
60	01E B 60M	SNC513	80	226	242	M16	280	70	32	180	104	4.9
65	01E B 65M	SNC515	80	226	242	M16	280	70	32	180	104	4.9
70	01E B 70M	SNC516	95	254	266	M20	315	90	38	208	114	7.3
75	01E B 75M	SNC517	95	254	266	M20	315	90	38	208	114	7.3
80	01E B 80M	SNC518	100	284	296	M20	345	100	32	240	136	13.4
85	01E B 85M	SNC519	112	284	296	M20	345	100	44	252	136	15.2
90	01E B 90M	SNC520	112	312	328	M24	380	90	44	252	136	13.3
100	01E B 100M	SNC522	125	342	366	M24	420	102	52	272	134	14.7
110	01 B 110M	SNC524	140	344	356	M24	410	120	45	310	142	19.5
115	01 B 115M	SNC526	150	372	388	M24	450	130	50	320	142	22.7
125	01 B 125M	SNC528	150	414	426	M30	500	150	50	360	156	38.2
135	01 B 135M	SNC530	160	444	456	M30	530	160	56	386	168	40
140	01 B 140M	SNC532	170	462	478	M30	558	178	41	391	168	52

(1) For full references of bearings and cartridges see pages 30 to 36

(2) Applies for cartridges with either single seal groove or TL seals

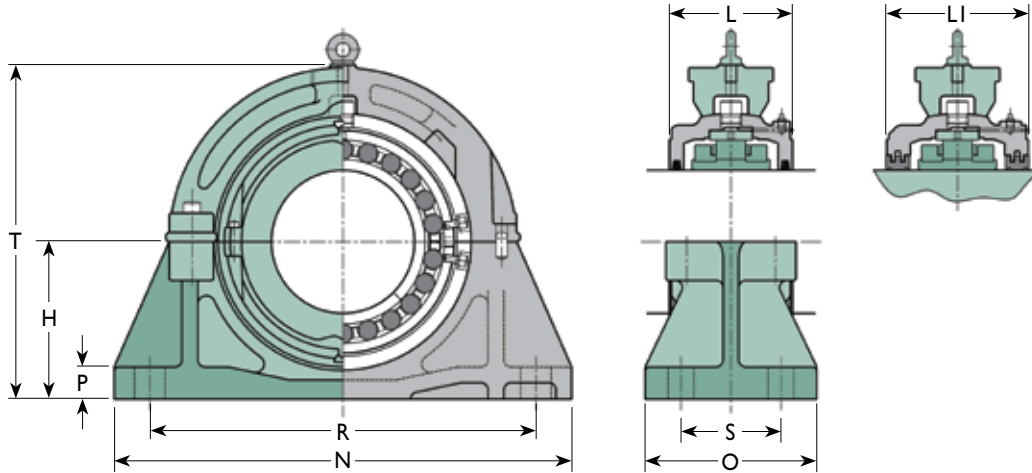

Shaft Diameter d (mm)	Bearing Reference(1)	Reference(1) (pedestal only)	H (mm)	R		S (mm)	Bolt size	N (mm)	O (mm)	P (mm)	T (mm)	L (mm)	LI (mm)	Pedestal Mass (kg)
				Min. (mm)	Max. (mm)									
150	01 B 150M	SDC3134	170	424	436	100	M24	510	178	41	401	174	174	48
160	01 B 160M	SDC3136	180	438	462	110	M24	530	190	40	396	172	192	50
170	01 B 170M	SDC3138	190	468	492	120	M24	560	200	40	425	172	200	59
180	01 B 180M	SDC3140	210	503	517	130	M30	600	210	40	445	172	200	66
	02 B 180M	02SDC3140	210	503	517	130	M30	600	210	40	482	222	242	96
200	01 B 200M	SDC3144	220	533	547	140	M30	640	240	45	467	172	200	87
220	01 B 220M	SDC3148	240	593	607	150	M30	700	250	45	510	178	216	96
240	01 B 240M	SDC3152	260	642	658	160	M36	770	280	49	552	188	222	132
260	01 B 260M	SDC3156	280	662	678	160	M36	790	280	55	591	204	232	160
280	01 B 280M	SDC3160	300	702	718	190	M36	830	310	55	611	204	232	175
300	01 B 300M	SDC3164	320	742	758	200	M36	880	320	60	663	216	248	208

(1) For full references of bearings and cartridges see pages 36 to 42

SAF COMPATIBLE PEDESTALS

2 Bolt SAFC

4 Bolt SAFC

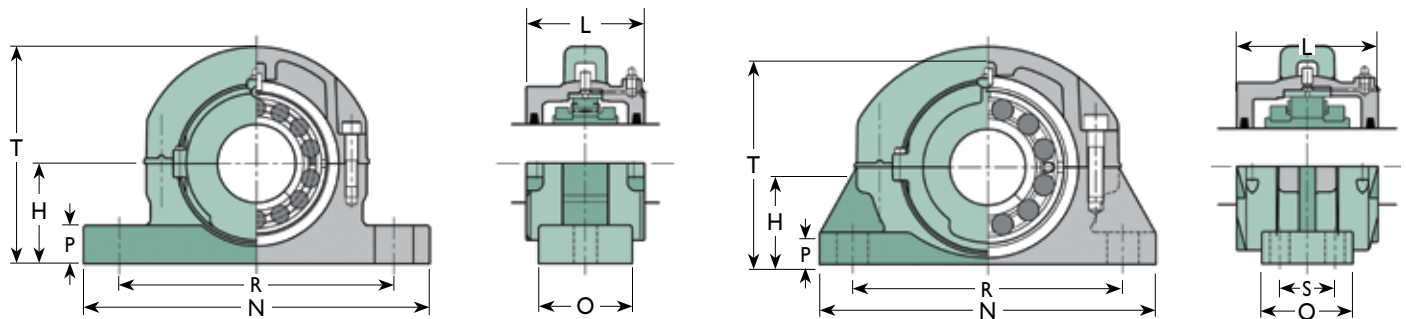

Shaft Diameter d (inches)	Bearing Reference(1)	Reference(1) (pedestal only)	H	R		S	Bolts		N	O	P	T	L(2)	Pedestal Mass (kg)
				Min.	Max.		No.	Size						
1 ⁵ / ₁₆	01E B 115	SAFCS11	2 ³ / ₄ "	7 ³ / ₈ "	7 ⁷ / ₈ "	-	2	5/8"	9 ⁵ / ₈ "	2 ³ / ₄ "	7/8"	6 ¹ / ₈ "	3 ¹³ / ₁₆ "	4.3
2 ³ / ₁₆	01E B 203	SAFCS13	3"	8 ⁵ / ₈ "	9 ¹ / ₂ "	-	2	5/8"	11"	3 ¹ / ₈ "	1"	7"	4 ¹ / ₁₆ "	6.4
2 ⁷ / ₁₆	01E B 207	SAFCS15	3 ¹ / ₄ "	8 ⁷ / ₈ "	9 ⁵ / ₈ "	-	2	5/8"	11 ¹ / ₄ "	3 ³ / ₈ "	1 ¹ / ₈ "	7 ¹ / ₄ "	4 ¹ / ₁₆ "	7.4
2 ¹¹ / ₁₆	01E B 211	SAFCS16	3 ¹ / ₂ "	9 ⁵ / ₈ "	11"	-	2	3/4"	13"	3 ¹ / ₂ "	1 ³ / ₁₆ "	7 ⁷ / ₈ "	4 ¹ / ₂ "	9.7
2 ¹⁵ / ₁₆	01E B 215	SAFCS17	3 ³ / ₄ "	9 ⁷ / ₈ "	11"	-	2	3/4"	13"	3 ¹ / ₂ "	1 ¹ / ₁₆ "	8 ⁵ / ₈ "	4 ¹ / ₂ "	11.5
	02 B 215	FSAFCS17	3 ³ / ₄ "	10"	10 ⁷ / ₈ "	2 ¹ / ₈ "	4	5/8"	13"	3 ¹ / ₂ "	1 ¹ / ₄ "	8 ¹ / ₂ "	5 ¹ / ₂ "	11.5
3 ¹ / ₁₆	01E B 303	SAFCS18	4"	10 ³ / ₈ "	11 ⁵ / ₈ "	-	2	3/4"	13 ³ / ₈ "	3 ⁷ / ₈ "	1 ¹ / ₄ "	9 ¹ / ₂ "	5 ⁵ / ₁₆ "	15.4

Shaft Diameter d (inches)	Bearing Reference(1)	Reference(1) (pedestal only)	H	R		S	Bolts		N	O	P	T	L(2)	Pedestal Mass (kg)
				Min.	Max.		No.	Size						
3 ⁷ / ₁₆	01E B 307	SAFCS20	4 ¹ / ₂ "	11 ⁵ / ₈ "	13 ¹ / ₈ "	-	2	7/8"	15 ¹ / ₄ "	3 ⁷ / ₈ "	1 ³ / ₄ "	10"	5 ¹ / ₁₆ "	19.3
	02 B 307	FSAFCS20	4 ¹ / ₂ "	11 ⁵ / ₈ "	13 ¹ / ₈ "	2 ³ / ₈ "	4	3/4"	15 ¹ / ₄ "	4 ³ / ₈ "	1 ³ / ₄ "	10 ¹ / ₄ "	6 ¹ / ₁₆ "	15.0
3 ¹⁵ / ₁₆	02 B 315	SAFCS22	4 ¹⁵ / ₁₆ "	12 ⁵ / ₈ "	14 ¹ / ₂ "	2 ³ / ₄ "	4	3/4"	16 ¹ / ₂ "	4 ³ / ₄ "	2"	11 ⁵ / ₈ "	5 ³ / ₄ "	19.5
4 ¹ / ₁₆	02 B 407	SAFCS26	6"	14 ⁵ / ₈ "	16"	3 ¹ / ₄ "	4	7/8"	18 ³ / ₈ "	5 ¹ / ₈ "	2 ³ / ₈ "	14 ¹ / ₄ "	6 ³ / ₈ "	43
4 ⁵ / ₁₆	02 B 415 (3)	SAFCS28 (3)	6"	16"	17 ⁵ / ₈ "	3 ³ / ₈ "	4	1"	20 ¹ / ₈ "	5 ⁷ / ₈ "	1 ³ / ₈ "	15"	7 ¹ / ₄ "	54
5 ¹ / ₁₆	02 B 507	SAFCS32	6 ¹ / ₁₆ "	17 ³ / ₈ "	19 ¹ / ₄ "	3 ³ / ₄ "	4	1"	22"	6 ¹ / ₄ "	2 ¹ / ₁₆ "	16 ³ / ₄ "	7 ³ / ₈ "	74
5 ¹⁵ / ₁₆	02 B 515	SAFCS34	7 1/16"	19 ³ / ₈ "	21 ⁵ / ₈ "	4 ¹ / ₄ "	4	1"	24 ¹ / ₄ "	6 ³ / ₄ "	2 ³ / ₄ "	17 ¹ / ₄ "	8"	83

(1) For full references of bearings and cartridges see pages 50 to 58

(2) Applies for cartridges with either single seal groove or TL seals

(3) Special bearing and cartridge required for this size. Bearing ratings are as for standard 02 B 415, but outside diameters of bearing and cartridge differ from standard.

References: Fixed-type bearing: 02 B 415 GR 16
 Expansion-type bearing: 02 B 415 EX 16
 Fixed-type cartridge (for TL seals): 02 C 10 GR 21
 Expansion-type cartridge (for TL seals): 02 C 10 EX 21

Sealing options

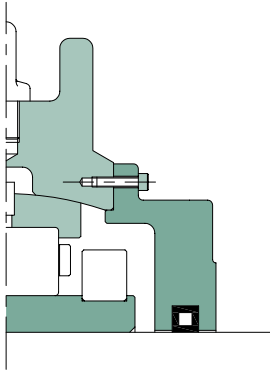

Flexible packing seal (FP)

Aramid braid wound around a flexible polymeric core to accommodate misalignment between the shaft and pedestal. Suitable for general dry applications, including materials handling.

Temperature limits	-20°C to 100°C
Maximum speed	50,000 dn(mm)
Maximum misalignment	0.25°
Shaft surface finish	1.6µm Ra (max. roughness)

Synthetic rubber single lip (SRS)

High temperature version (SRS HT)

Low temperature version (SRS LT)

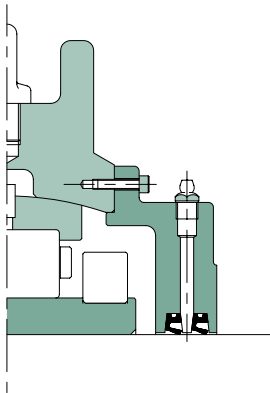

Synthetic rubber single lip (SRS)

Suitable for wet but not submerged conditions.

Temperature limits	SRS	-20°C to 100°C
	SRS HT	20°C to 175°C
	SRS LT	-60°C to 100°C
Maximum speed		150,000 dn(mm)
Maximum misalignment		0.25°
Shaft surface finish		0.8µm Ra (max. roughness)

Aluminium triple labyrinth (ATL)

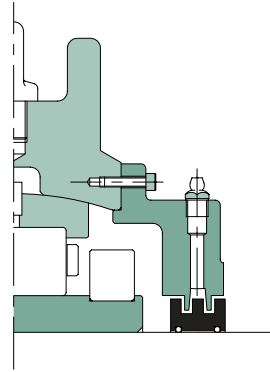

Aluminium triple labyrinth (ATL)

High temperature version (ATL HT)

Low temperature version (ATL LT)

Machined aluminium-bodied triple labyrinth seal capable of high speed operation. Often used on fans.

Temperature limits	ATL	-20°C to 100°C
	ATL HT	20°C to 175°C
	ATL LT	-60°C to 100°C
Maximum speed		Bearing maximum
Maximum misalignment		0.5°
Shaft surface finish		3.2µm Ra (max. roughness)

Lubrication

Fittings

Lubrication points are tapped 1/8" NPT or 1/4" NPT and fitted with nipples for grease lubrication as standard. Nipples may be removed and replaced with other fittings or pipes.

Housings for flexible packing seals have one lubrication point only, for lubrication of the bearing. Housings for SRS or ATL seals also have a lubrication point in each end cover for lubrication of the seals.

Lubricant type

Cooper SD Series housings are designed for grease lubrication. Greases of NLGI No.2 designation are recommended for most applications. For centrally pumped systems a No.1 grease may be used for increased 'pumpability'.

Greases with extreme pressure (EP) additives are recommended and are essential if the full axial load capacity of the bearing is to be used.

Grease with a lithium complex thickener is usually used for normal applications operating at temperatures between 0°C and 80°C. When water resistance is required a grease with aluminium complex thickener can be used. Aluminium complex greases are not compatible with some other types of grease. The bearing must therefore be solvent cleaned of other greases before adding an aluminium complex based grease.

For extreme temperatures, speeds and loads always obtain a lubricant recommendation from our technical department.

For principles of selection of base oil viscosity refer to page 25. The geometry factors required when referring to the charts on page 27 are given in the table below.

GEOMETRY FACTOR

Shaft Diameter (mm)	Bearing Reference	Geometry factor
150	08 B 150M EX	176
	08 B 150M GR	
160	08 B 160M EX	176
	08 B 160M GR	
200	08 B 200M EX	258
	08 B 200M GR	
220	08 B 220M EX	297
	08 B 220M GR	
240	08 B 240M EX	343
	08 B 240M GR	

Grease quantity for initial lubrication

The quantity of grease required on initial lubrication is dependent upon operating speed and temperature.

If the operating temperature is below 80°C the quantity of grease may be determined directly according to the bearing reference and operating speed from the table below. If the operating temperature is above 80°C a 25% pack of grease should be used regardless of operating speed (refer to the right hand column of the table).

With a 'full pack' of grease the space within the housing (i.e. surrounding the bearing components) in the assembled unit is completely filled with grease.

The table assumes normal density grease (about 0.85 g/cm³).

Routine greasing

If possible, the bearing should be re-greased as it rotates. Lubricate the bearing via the lubrication point in the pedestal cap.

Expansion bearings (EX): Lubricate every 400 hours. This frequency may be increased to weekly if desired. For 150mm and 160mm sizes use approximately 4ml of grease (generally 2 shots of grease from a conventional grease gun) For larger sizes use approximately 8ml of grease (generally 4 shots).

Fixed bearing (GR): Lubricate the bearing weekly (i.e. approximately every 150hours operation). For 150mm and 160mm sizes use approximately 4ml of grease (generally 2 shots of grease from a conventional grease gun). For larger sizes use approximately 8ml of grease (generally 4 shots). If the bearing is used for location only (i.e. there is no nominal axial load) it may be treated as per the expansion bearing of the same size for lubrication purposes.

INITIAL LUBRICANT QUANTITIES

Shaft Diameter (mm)	Pedestal Reference	Speed (rpm) up to	Grease (full pack) kg	Speed (rpm)		Grease (75% full pack) kg	Speed (rpm)		Grease (50% full pack) kg	Speed (rpm)		Grease (33% full pack) kg	Speed (rpm) over	Grease (25% full pack) kg
				from	to		from	to		from	to			
150	08 SDC3134	328	2.10	328	656	1.57	656	984	1.05	984	1312	0.69	1312	0.53
160	08 SDC3136	328	2.04	328	656	1.53	656	984	1.02	984	1312	0.67	1312	0.50
200	08 SDC3144	246	3.50	246	492	2.63	492	738	1.75	738	max.	1.16	-	0.88
220	08 SDC3148	219	3.62	219	437	2.72	437	656	1.81	656	max.	1.20	-	0.90
240	08 SDC3152	197	5.17	197	394	3.88	394	591	2.59	591	max.	1.71	-	1.30

Seals: If end covers with seal lubrication points are fitted the seals of both types of bearing should be lubricated with 2ml (one shot) of grease via each seal lubrication point every time the bearing is relubricated.

Pumped systems should be metered to supply equivalent quantities of lubricant to those specified above.

Frequency Data

Refer to page 16 for an explanation of bearing vibration and part frequencies. The data relating to the 08SDC range is given in the table right.

BEARING FREQUENCIES

Shaft Diameter (mm)	Bearing Reference	Part Frequencies (per shaft rev.)				Roller Details		
		Cage	Roller	Outer	Inner	PCD (mm)	No.	Diameter (mm)
150	08 B 150M EX 08 B 150M GR	0.421	3.103	6.743	9.257	222.25	16	34.93
160	08 B 160M EX 08 B 160M GR	0.421	3.103	6.743	9.257	222.25	16	34.93
200	08 B 200M EX 08 B 200M GR	0.428	3.389	6.844	9.156	285.75	16	41.28
220	08 B 220M EX 08 B 220M GR	0.434	3.703	7.806	10.194	311.15	18	41.28
240	08 B 240M EX 08 B 240M GR	0.435	3.792	7.833	10.167	342.90	18	44.45

TIGHTENING TORQUES

Shaft Diameter (mm)	Pedestal Reference	Bearing type	Clamping ring screw (I)			Outer race joint location strip screw (I)		
			Screw size	Key size A/F (mm)	Torque (Nm)	Screw size	Key size A/F (mm)	Torque (Nm)
150	08 SDC3134	EX or GR	M8 x 30	6	35	M4 x 12	2.5	2.7
160	08 SDC3136	EX or GR	M8 x 30	6	35	M4 x 12	2.5	2.7
200	08 SDC3144	EX or GR	M12 x 55	10	120	M4 x 12	2.5	2.7
220	08 SDC3148	EX or GR	M12 x 55	10	120	M4 x 12	2.5	2.7
240	08 SDC3152	EX	M16 x 65	14	300	M4 x 12	2.5	2.7
		GR	M12 x 55	10	120			

Tightening Torques

The tightening torques for the assembly of the bearings and housing are given in the table below. Full assembly instructions are packed with the bearings, and are available separately if required.

Shaft Diameter (mm)	Pedestal Reference	Bearing type	Outer race joint screw (I)			End cover to pedestal screw (I)			End cover joint screw (I)			Pedestal joint screw (I)		
			Screw size	Key size A/F (mm)	Torque (Nm)	Screw size	Key size A/F (mm)	Torque (Nm)	Screw size	Key size A/F (mm)	Torque (Nm)	Screw size	Key size A/F (mm)	Torque (Nm)
150	08 SDC3134	EX or GR	M5 x 25	4	8.5	M6 x 25	5	11	M6 x 25	5	11	M20 x 80	17	420
160	08 SDC3136	EX or GR	M5 x 25	4	8.5	M6 x 25	5	11	M6 x 25	5	11	M20 x 80	17	420
200	08 SDC3144	EX or GR	M5 x 30	4	8.5	M6 x 25	5	11	M8 x 30	6	26	M24 x 100	19	712
220	08 SDC3148	EX or GR	M5 x 30	4	8.5	M8 x 30	6	26	M8 x 30	6	26	M24 x 100	19	712
240	08 SDC3152	EX	M6 x 30	5	15	M8 x 30	6	26	M8 x 30	6	26	M30 x 120	22	1568
		GR												

I) All screws are metric coarse thread, grade 12.9

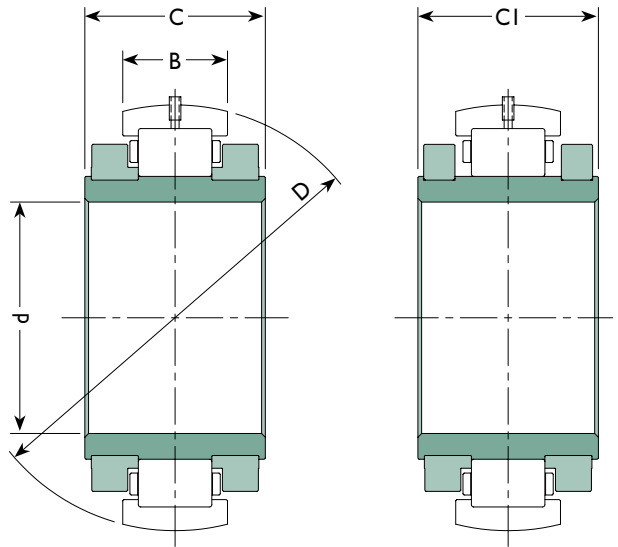
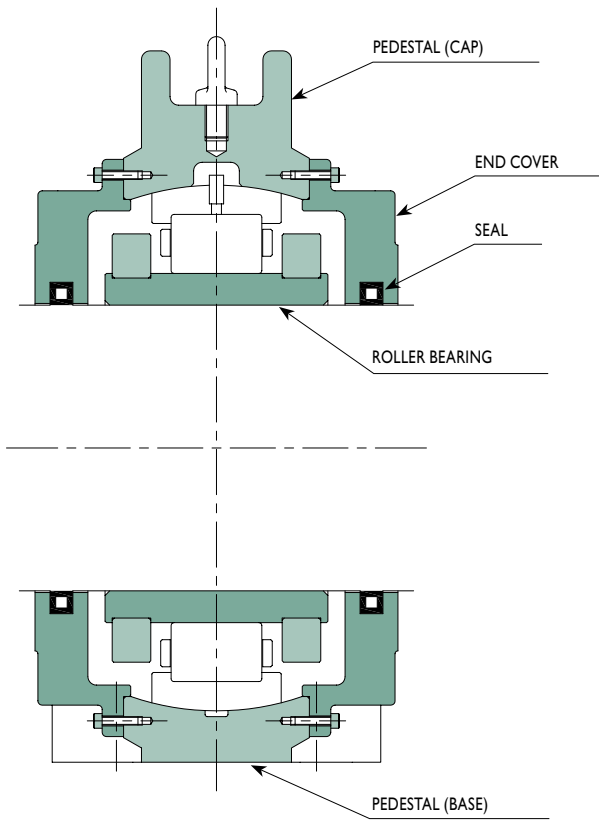

76

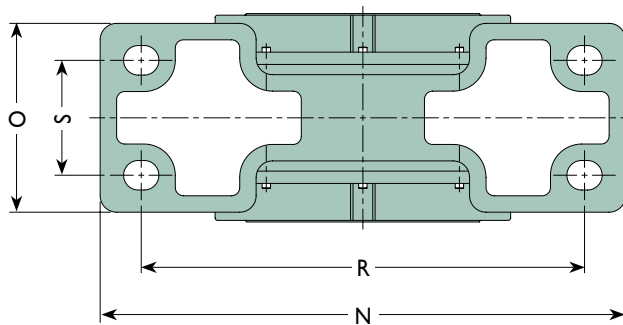
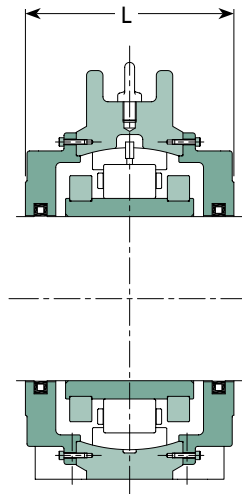
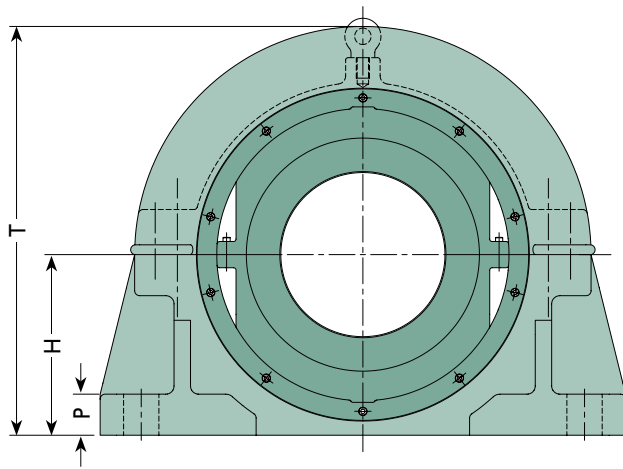

ROLLER BEARING

Shaft Diameter d (mm)	References		Bearing Ratings				Principal Dimensions				Axial Movement (1) (mm)	Mass (kg)
	Expansion Type	Fixed Type	Cr (kN)	Cor (kN)	Ca (kN)	Max. Speed (rpm)	D	C	CI	B		
150	08 B 150M EX	08 B 150M GR	724	1005	52.4	1320	292	123.8	123.8	68.5	10	29
160	08 B 160M EX	08 B 160M GR	724	1005	52.4	1320	292	123.8	123.8	68.5	10	27
180	180mm size available in 02 Series. Refer to page 71											
200	08 B 200M EX	08 B 200M GR	998	1457	80.0	960	368	156	156	90.5	10	49
220	08 B 220M EX	08 B 220M GR	1082	1662	89.8	850	395	163	163	90.5	14	58
240	08 B 240M EX	08 B 240M GR	1149	1756	98.8	750	432	170	178	96.8	18	92

PEDESTAL, END COVERS AND SEALS

Pedestal	References								
	End Cover (2)			Pedestal complete with End Covers			Seal (2)		
	To suit FP seal	To suit SRS seals	To suit ATL seal	To suit FP seal	To suit SRS seals	To suit ATL seal	FP	SRS	ATL
08SDC3134	EC150M	EC150MSRS	EC31	08SDC3134 EC	08SDC3134 ECSRS	08SDC3134 ECTL	FP150M	SR 150M	ATL 150M08
08SDC3136	EC160M	EC160MSRS	EC3110	08SDC3136 EC	08SDC3136 ECSRS	08SDC3136 ECTL	FP160M	SR 160M	ATL 160M08
180mm size available in 02 Series. Refer to page 71									
08SDC3144	EC200M	EC200MSRS	EC34	08SDC3144 EC	08SDC3144 ECSRS	08SDC3144 ECTL	FP200M	SR 200M	ATL 200M
08SDC3148	EC220M	EC220MSRS	EC35	08SDC3148 EC	08SDC3148 ECSRS	08SDC3148 ECTL	FP220M	SR 220M	ATL 220M08
08SDC3152	EC240M	EC240MSRS	EC36	08SDC3152 EC	08SDC3152 ECSRS	08SDC3152 ECTL	FP240M	SR 240M	ATL 240M08

PRINCIPAL HOUSING DIMENSIONS

H	R (mm)		S	Bolt Size	N	O	P	T	L	Mass (kg)			Shaft Diameter d (mm)
	Min.	Max.								Pedestal Only	End Covers (full set)	Complete Unit (with bearing)	
170	424	436	100	M24	510	170	40	395	220	49	25	103	150
180	444	456	110	M24	530	180	40	405	220	52	24	103	160
180mm size available in 02 Series. Refer to page 71													180
220	533	547	140	M30	640	230	50	498	256	89	42	180	200
240	593	607	150	M30	700	240	55	540	261	117	47	222	220
260	642	658	160	M36	770	270	60	585	280	143	58	293	240

1) Total available movement available in expansion bearing. Maximum offset from centreline half this amount.

2) 2 off required per unit

Flanges provide a simple means of mounting Cooper split roller bearings against a vertical or horizontal face or bulkhead.

The bearings are housed in standard Cooper cartridges (refer to page 28).

The top halves of both flange and cartridge can be lifted for inspection once installed (provided that the shaft can be maintained safely in position).

The sizes listed on the following pages are the standard sizes that are manufactured regularly. As with other Cooper housings, particulars of alternative versions or sizes not listed can be supplied on request.

The most common type of flange is the round flange as illustrated below and listed on pages 80 to 93. These flanges are manufactured from grey iron as standard. Ductile iron and steel flanges are also available.

ROUND FLANGE

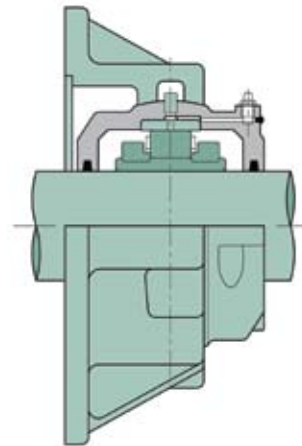
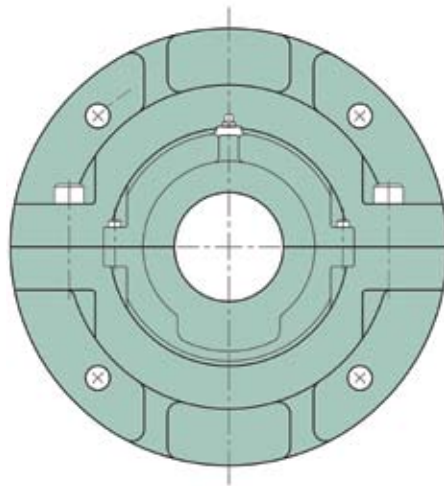

78

For bearings from 45mm to 85mm / 1 1/16" to 3 7/16" shaft size, a more compact alternative is the square ('DF Line') flange as illustrated below and listed on pages 94 to 95.

Square flanges are manufactured from ductile iron as standard and are ideal for use on steel frames or skid mounted equipment.

DF FLANGE

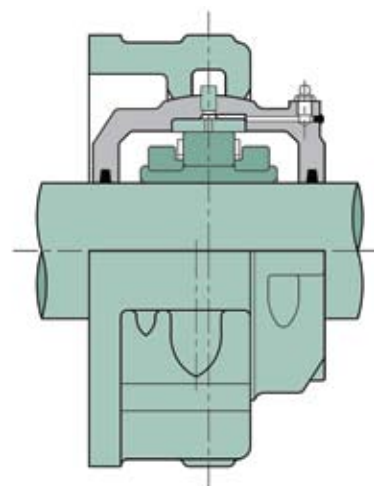
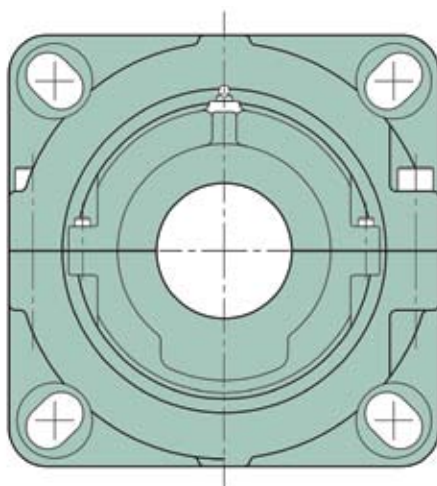

A further option, where it is desired for the bearing centre to be closer to the mounting face, is the 'flat flange'.

FLAT FLANGE

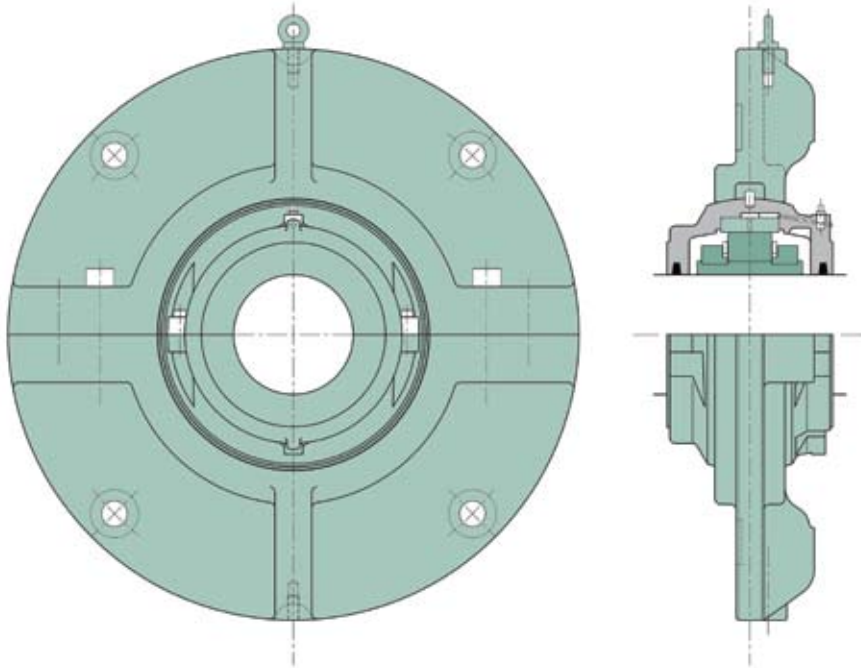

A typical application is on electric motors, where the flat flange is used to enclose the end of the motor housing as well as support the bearing.

Although the unit cannot be disassembled in a completely radial direction, by providing a sufficiently large aperture in the mounting face it is still possible to inspect and replace the bearing without disturbing the shaft.

If you wish to specify a flat flange please contact our technical department for details.

Flanges are common between expansion (EX) and fixed (GR) units. Where flat flanges are used on electrical equipment single lipped (GROSL) bearings are often specified (see page 5).

LOADS AND MOUNTING

The maximum radial load for standard round and square flanges is 26% of the static rating (C_{or}) of the corresponding roller bearing for 01, 01E and 02 Series bearings, and 20% C_{or} for 100 Series bearings.

The maximum axial load is 25% of the axial rating (C_a) of the corresponding roller bearing for 01, 01E and 02 Series bearings, and 18% C_a for 100 Series bearings.

Ductile iron or steel flanges should be specified for shock conditions. Particulars are available on request from our technical department.

Standard flanges normally have drilled holes for the mounting bolts, with the outer surface as-cast. It is recommended that

flat washers are fitted under the bolt heads. Cast steel flanges usually have drilled holes with spotfacings for the bolt heads.

The rear face of round flanges is recessed for use with a spigot if required.

The bulkhead or support plate on which the flange is mounted must be of adequate strength and rigidity to support the imposed load with little distortion of the flange mounting area.

For vertical shafts bearings and flanges may require modified construction and special seals and lubrication. Please consult our technical department when considering applications with vertical shafts.

R p.c.d. – holes equally spaced

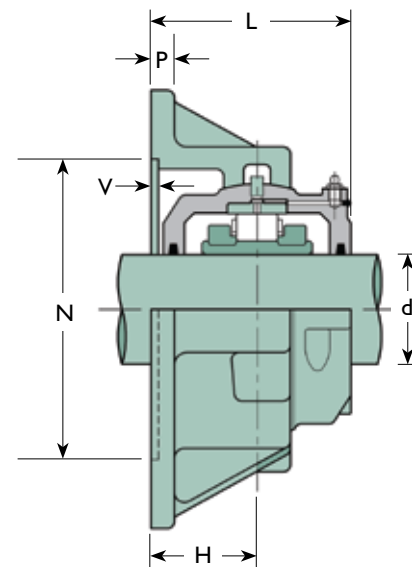
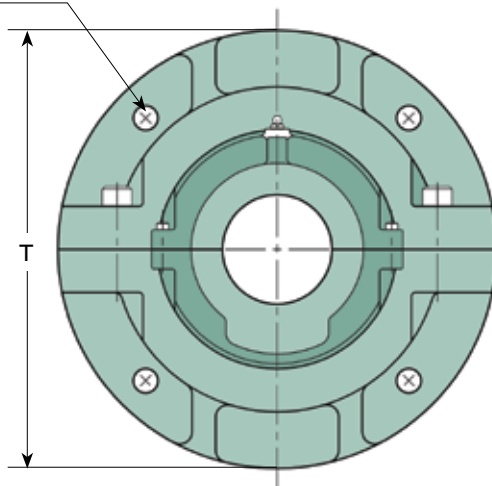

Shaft Diameter d (mm)	Bearing Reference(1)	Reference(1) (flange only)	T(2) (mm)	Bolts			R (mm)	P (mm)	H (mm)	N(3) (mm)	V(3) (mm)	L(4) (mm)	Mass (flange only) (kg)
				No.	Metric Size	Inch Size							
35	01 B 35M	F01	204	4	M12	½"	164	13	51	119.06	3	94	4.2
40	01 B 40M	F01	204	4	M12	½"	164	13	51	119.06	3	94	4.2
45	01E B 45M	F02	216	4	M12	½"	180	13	57	136.53	3	106	5.1
50	01E B 50M	F02	216	4	M12	½"	180	13	57	136.53	3	106	5.1
	02 B 50M	F03	260	4	M12	½"	218	16	67	166.69	3	124	9.1
55	01E B 55M	F03	260	4	M12	½"	218	16	67	166.69	3	119	9.1
60	01E B 60M	F03	260	4	M12	½"	218	16	67	166.69	3	119	9.1
	02 B 60M	F04	286	4	M12	½"	242	16	73	192.09	3	136	12.4
65	01E B 65M	F03	260	4	M12	½"	218	16	67	166.69	3	119	9.1
	02 B 65M	F04	286	4	M12	½"	242	16	73	192.09	3	136	12.4
70	01E B 70M	F04	286	4	M12	½"	242	16	73	192.09	3	130	12.4
	02 B 70M	F05	330	4	M16	5/8"	274	19	79	215.90	3	149	19.4
75	100 B 75M	F03	260	4	M12	½"	218	16	67	166.69	3	119	9.1
	01E B 75M	F04	286	4	M12	½"	242	16	73	192.09	3	130	12.4
	02 B 75M	F05	330	4	M16	5/8"	274	19	79	215.90	3	149	19.4

(1) For full references of bearings and cartridges see pages 30 to 34

(2) Dimension shown is as-cast dimension. Depending upon manufacturing method used, flanges supplied may be machined 5mm smaller

METRIC ROUND FLANGE-MOUNTED UNITS TO 110mm BORE SIZE

R p.c.d. – holes equally spaced

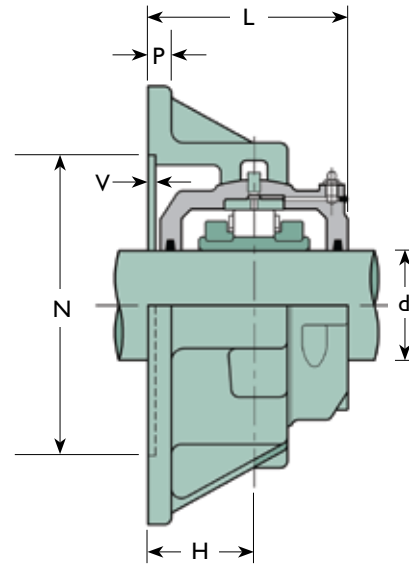
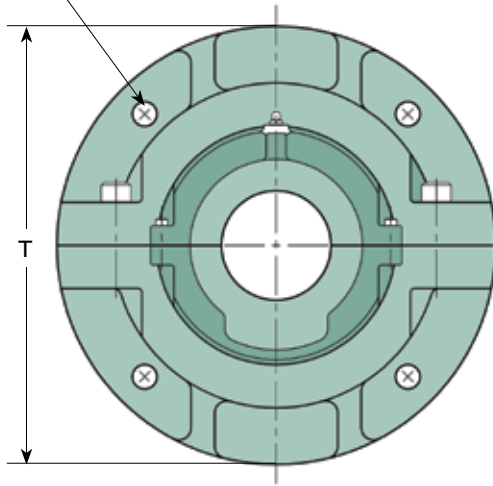

Shaft Diameter d (mm)	Bearing Reference(1)	Reference(1) (flange only)	T(2) (mm)	Bolts			R (mm)	P (mm)	H (mm)	N(3) (mm)	V(3) (mm)	L(4) (mm)	Mass (flange only) (kg)
				No.	Metric Size	Inch Size							
80	01E B 80M	F05	330	4	M16	5/8"	274	19	79	215.90	3	147	19.4
	02 B 80M	F06	356	4	M16	5/8"	302	19	86	244.48	3	163	22.0
85	100 B 85M	F04	286	4	M12	1/2"	242	16	73	192.09	3	130	12.4
	01E B 85M	F05	330	4	M16	5/8"	274	19	79	215.90	3	147	19.4
	02 B 85M	F06	356	4	M16	5/8"	302	19	86	244.48	3	163	22.0
90	01E B 90M	F05	330	4	M16	5/8"	274	19	79	215.90	3	147	19.4
	02 B 90M	F06	356	4	M16	5/8"	302	19	86	244.48	3	163	22.0
95	01E B 95M	F06	356	4	M16	5/8"	302	19	86	244.48	3	153	22.0
100	100 B 100M	F05	330	4	M16	5/8"	274	19	79	215.90	3	147	19.4
	01E B 100M	F06	356	4	M16	5/8"	302	19	86	244.48	3	153	22.0
	02 B 100M	F07	382	4	M16	5/8"	334	22	92	276.23	3	165	26.6
105	01E B 105M	F06	356	4	M16	5/8"	302	19	86	244.48	3	153	22.0
	02 B 105M	F07	382	4	M16	5/8"	334	22	92	276.23	3	165	26.6
110	100 B 110M	F06	356	4	M16	5/8"	302	19	86	244.48	3	153	22.0
	01 B 110M	F07	382	4	M16	5/8"	334	22	92	276.23	3	163	26.6
	02 B 110M	F08	432	4	M24	1"	374	22	98	314.33	3	179	34.9

(3) Dimensions shown are for locating spigot for mounting flange on to. Diameter tolerance of locating spigot: f8

(4) Applies for cartridges with either single seal groove or TL seals

R p.c.d. – holes equally spaced

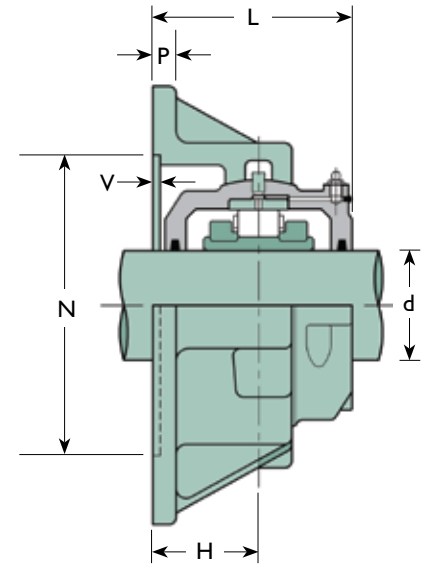
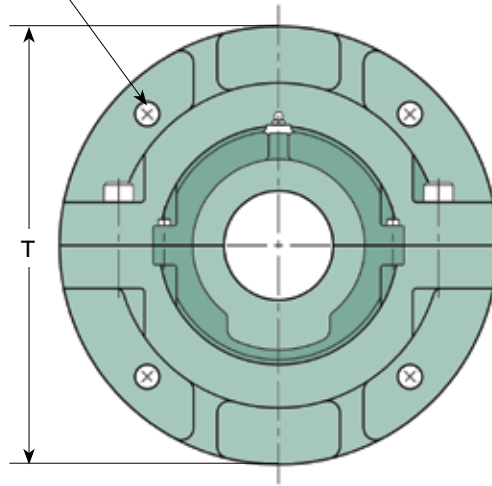

Shaft Diameter d (mm)	Bearing Reference(1)	Reference(1) (flange only)	T(2) (mm)	Bolts			R (mm)	P (mm)	H (mm)	N(3) (mm)	V(3) (mm)	L(4) (mm)	Mass (flange only) (kg)
				No.	Metric Size	Inch Size							
115	01 B 115M	F07	382	4	M16	5/8"	334	22	92	276.23	3	163	26.6
	02 B 115M	F08	432	4	M24	1"	374	22	98	314.33	3	179	34.9
120	100 B 120M	F07	382	4	M16	5/8"	334	22	92	276.23	3	163	26.6
	01 B 120M	F08	432	4	M24	1"	374	22	98	314.33	3	176	34.9
	02 B 120M	F10	470	4	M24	1"	412	25	114	346.07	3	206	50.2
125	01 B 125M	F08	432	4	M24	1"	374	22	98	314.33	3	176	34.9
	02 B 125M	F10	470	4	M24	1"	412	25	114	346.07	3	206	50.2
130	100 B 130M	F07	382	4	M16	5/8"	334	22	92	276.23	3	163	26.6
	01 B 130M	F08	432	4	M24	1"	374	22	98	314.33	3	176	34.9
	02 B 130M	F10	470	4	M24	1"	412	25	114	346.07	3	206	50.2
135	01 B 135M	F09	444	4	M24	1"	384	25	98	317.50	3	182	40.8
	02 B 135M	F30	508	4	M24	1"	444	25	114	377.82	3	208	67
140	100 B 140M	F08	432	4	M24	1"	374	22	98	314.33	3	176	34.9
	01 B 140M	F09	444	4	M24	1"	384	25	98	317.50	3	182	40.8
	02 B 140M	F30	508	4	M24	1"	444	25	114	377.82	3	208	67

(1) For full references of bearings and cartridges see pages 34 to 36

(2) Dimension shown is as-cast dimension. Depending upon manufacturing method used, flanges supplied may be machined 5mm smaller

METRIC ROUND FLANGE-MOUNTED UNITS FROM 115mm TO 155mm BORE SIZE

R p.c.d. – holes equally spaced

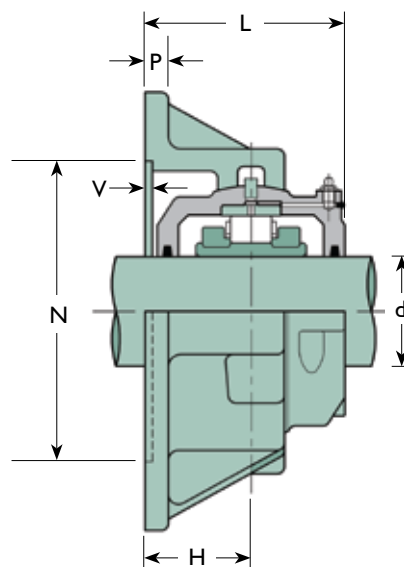
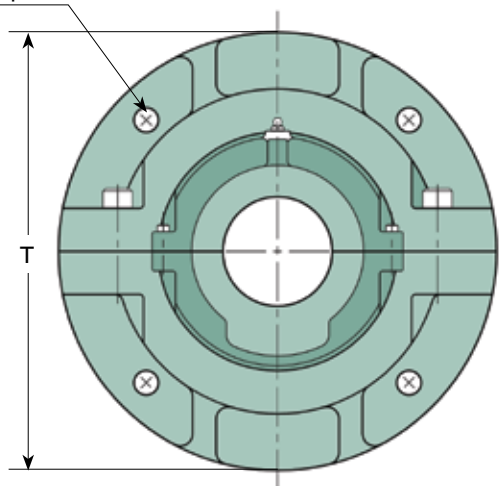

Shaft Diameter d (mm)	Bearing Reference(1)	Reference(1) (flange only)	T(2) (mm)	Bolts			R (mm)	P (mm)	H (mm)	N(3) (mm)	V(3) (mm)	L(4) (mm)	Mass (flange only) (kg)
				No.	Metric Size	Inch Size							
145	02 B 145M	F30	508	4	M24	1"	444	25	114	377.82	3	208	67
	100 B 150M	F09	444	4	M24	1"	384	25	98	317.50	3	182	40.8
150	01 B 150M	F10	470	4	M24	1"	412	25	114	346.07	3	201	50.2
	02 B 150M	F31	534	4	M24	1"	466	25	124	393.70	3	226	81
155	01 B 155M	F10	470	4	M24	1"	412	25	114	346.07	3	201	50.2
	02 B 155M	F31	534	4	M24	1"	466	25	124	393.70	3	226	81

(3) Dimensions shown are for locating spigot for mounting flange on to. Diameter tolerance of locating spigot: f8

(4) Applies for cartridges with either single seal groove or TL seals

R pcd – holes equally spaced

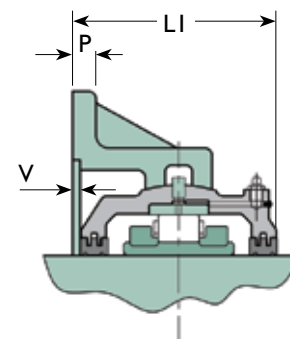
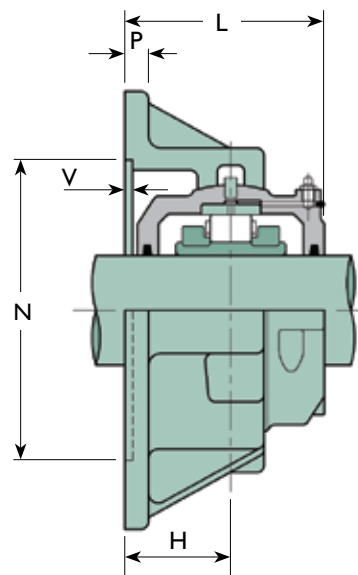
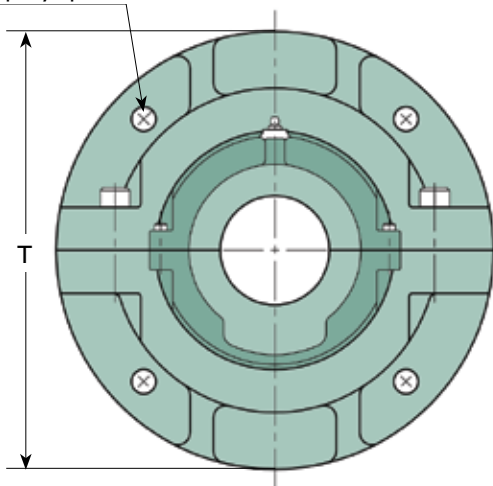

Shaft Diameter d (mm)	Bearing Reference(1)	Reference(1) (flange only)	T(2) (mm)	Bolts			R (mm)	P (mm)	H (mm)	N(3) (mm)	V(3) (mm)	L (mm)	LI (mm)	Mass (flange only) (kg)
				No.	Metric Size	Inch Size								
160	01 B 600-160M	F10	470	4	M24	1"	412	25	114	346.07	3	201	201	50.2
	01 B 160M	F11	496	4	M24	1"	426	25	105	352.43	3	191	201	58
	02 B 600-160M	F31	534	4	M24	1"	466	25	124	393.70	3	226	226	81
	02 B 160M	F32	584	4	M30	1¼"	508	29	124	428.63	5	227	240	95
170	01 B 608-170M	F11	496	4	M24	1"	426	25	105	352.43	3	191	201	58
	01 B 170M	F12	508	4	M24	1"	438	29	108	365.13	3	194	208	62
	02 B 170M	F32	584	4	M30	1¼"	508	29	124	428.63	5	227	240	95
175	01 B 175M	F12	508	4	M24	1"	438	29	108	365.13	3	194	208	62
	02 B 175M	F33	596	4	M30	1¼"	524	32	130	444.50	5	241	251	100
180	01 B 180M	F12	508	4	M24	1"	438	29	108	365.13	3	194	208	62
	02 B 180M	F33	596	4	M30	1¼"	524	32	130	444.50	5	241	251	100
190	01 B 190M	F13	534	4	M24	1"	474	32	108	400.05	3	194	208	71
	02 B 190M	F34	648	4	M30	1¼"	572	32	137	492.13	5	255	266	138
200	01 B 200M	F13	534	4	M24	1"	474	32	108	400.05	3	194	208	71
	02 B 200M	F34	648	4	M30	1¼"	572	32	137	492.13	5	255	266	138
220	01 B 220M	F14	584	4	M30	1¼"	512	35	117	431.80	3	206	225	85
	02 B 220M	F35	712	4	M36	1½"	620	35	146	527.05	5	267	283	145

(1) For full references of bearings and cartridges see pages 38 to 42

(2) Dimension shown is as-cast dimension. Depending upon manufacturing method used, flanges supplied may be machined 5mm smaller

METRIC ROUND FLANGE-MOUNTED UNITS FROM 160mm TO 300mm BORE SIZE

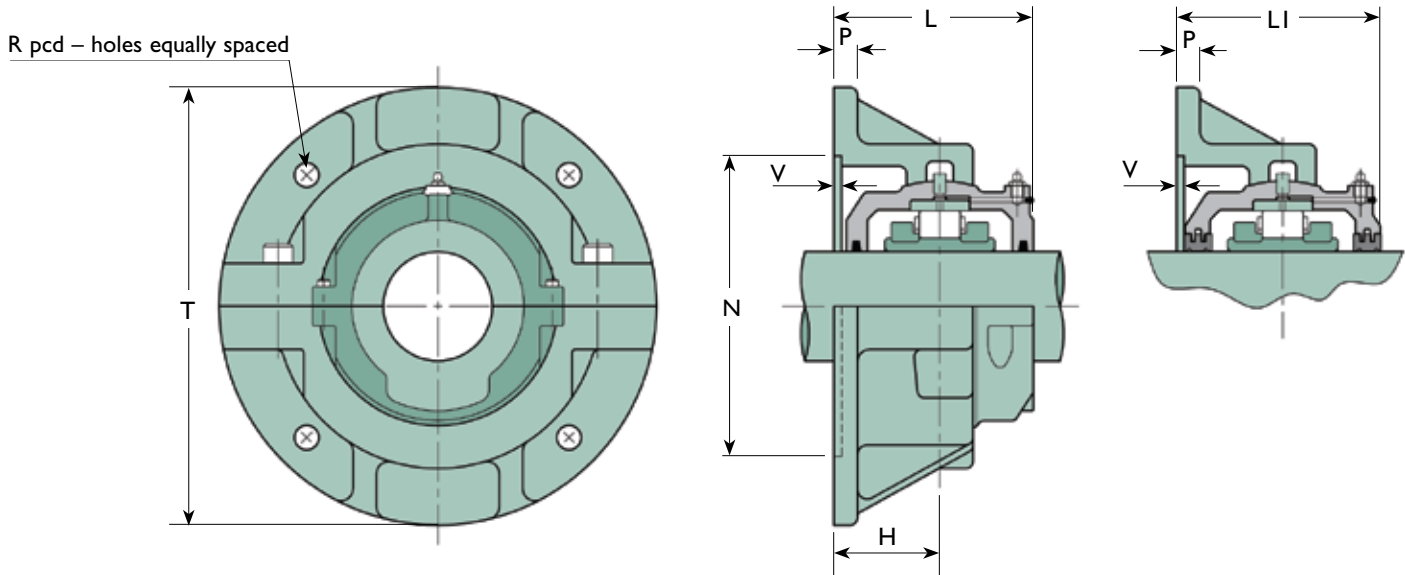

Shaft Diameter d (mm)	Bearing Reference(1)	Reference(1) (flange only)	T(2) (mm)	Bolts			R (mm)	P (mm)	H (mm)	N(3) (mm)	V(3) (mm)	L (mm)	LI (mm)	Mass (flange only) (kg)
				No.	Metric Size	Inch Size								
230	01 B 230M	F14	584	4	M30	1¼"	512	35	117	431.80	3	206	225	85
	02 B 230M	F35	712	4	M36	1½"	620	35	146	527.05	5	267	283	145
240	01 B 240M	F15	610	4	M30	1¼"	542	35	117	463.55	3	211	228	100
	02 B 240M	F36	736	4	M36	1½"	660	38	149	568.33	5	273	289	178
250	01 B 250M	F15	610	4	M30	1¼"	542	35	117	463.55	3	211	228	100
	02 B 250M	F36	736	4	M36	1½"	660	38	149	568.33	5	273	289	178
260	01 B 1000-260M	F15	610	4	M30	1¼"	542	35	117	463.55	3	211	228	100
	01 B 260M	F16	660	4	M30	1¼"	584	38	124	504.83	3	226	240	116
	02 B 260M	F36	736	4	M36	1½"	660	38	149	568.33	5	273	289	178
270	01 B 270M	F16	660	4	M30	1¼"	584	38	124	504.83	3	226	240	116
275	01 B 275M	F16	660	4	M30	1¼"	584	38	124	504.83	3	226	240	116
280	01 B 280M	F16	660	4	M30	1¼"	584	38	124	504.83	3	226	240	116
	02 B 280M	F37	762	8	M30	1¼"	682	38	159	603.25	5	291	309	195
290	01 B 290M	F17	712	4	M30	1¼"	626	38	133	539.75	3	241	257	119
300	01 B 300M	F17	712	4	M30	1¼"	626	38	133	539.75	3	241	257	119
	02 B 300M	F38	788	8	M30	1¼"	708	41	162	628.65	5	296	315	195

(3) Dimensions shown are for locating spigot for mounting flange on to. Diameter tolerance of locating spigot: f8

METRIC ROUND FLANGE-MOUNTED UNITS FROM 320mm TO 400mm BORE SIZE

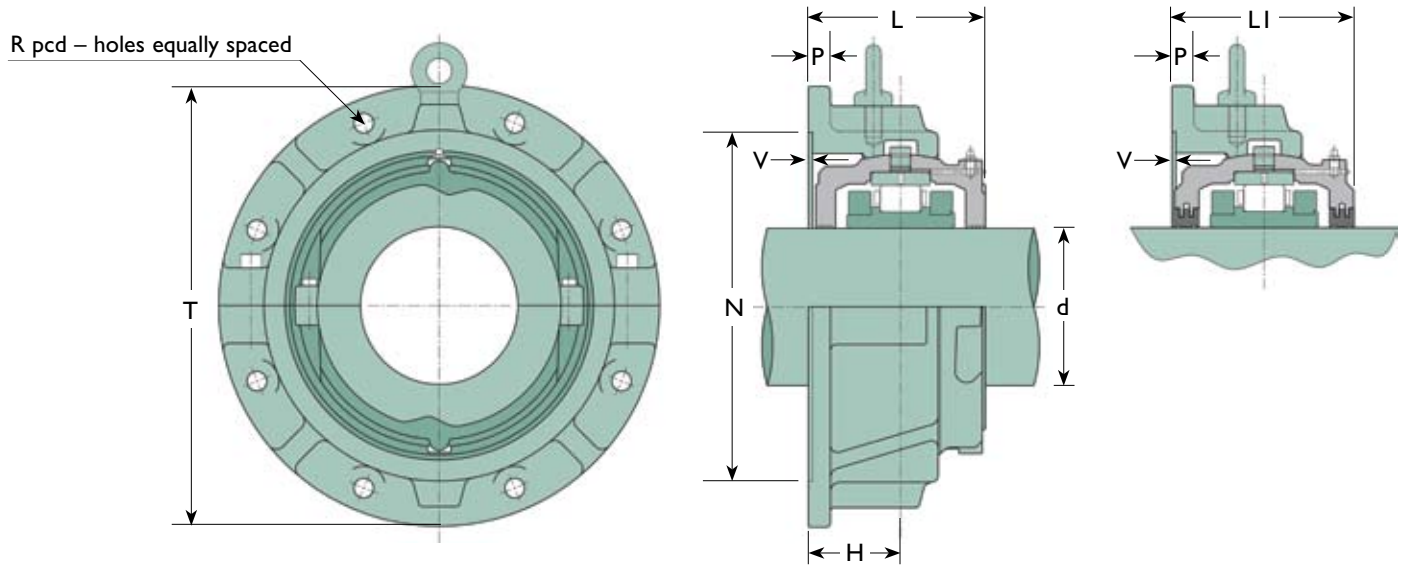

Shaft Diameter d (mm)	Bearing Reference(1)	Reference(1) (flange only)	T(2) (mm)	Bolts			R (mm)	P (mm)	H (mm)	N(3) (mm)	V(3) (mm)	L (mm)	LI (mm)	Mass (flange only) (kg)
				No.	Metric Size	Inch Size								
320	01 B 320M	F18	812	4	M36	1½"	698	38	152	584.20	5	282	288	184
	02 B 320M	F39	914	8	M30	1¼"	800	45	190	680.00	7	339	355	309
330	01 B 330M	F18	812	4	M36	1½"	698	38	152	584.20	5	282	288	184
	02 B 330M	F39	914	8	M30	1¼"	800	45	190	680.00	7	339	355	309
340	01 B 1300-340M	F18	812	4	M36	1½"	698	38	152	584.20	5	282	288	184
	01 B 340M	F19	850	4	M36	1½"	738	40	140	610.00	7	270	276	207
350	01 B 350M	F19	850	4	M36	1½"	738	40	140	610.00	7	270	276	207
360	01 B 1400-360M	F19	850	4	M36	1½"	738	40	140	610.00	7	270	276	207
	01 B 360M	F20	914	8	M30	1¼"	800	44	165	673.10	5	295	305	276
380	01 B 380M	F20	914	8	M30	1¼"	800	44	165	673.10	5	295	305	276
390	01 B 390M	F21	914	8	M30	1¼"	800	44	165	673.10	5	305	308	273
400	01 B 400M	F21	914	8	M30	1¼"	800	44	165	673.10	5	305	308	273

(1) For full references of bearings and cartridges see pages 44 and 46

(2) Dimension shown is as-cast dimension. Depending upon manufacturing method used, flanges supplied may be machined 5mm smaller

(3) Dimensions shown are for locating spigot for mounting flange on to. Diameter tolerance of locating spigot: f8

INCH-SIZE ROUND FLANGE-MOUNTED UNITS TO 2⁷/₁₆" BORE SIZE

R p.c.d. – holes equally spaced

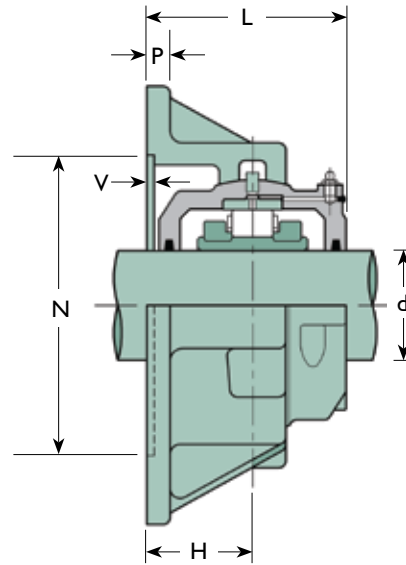
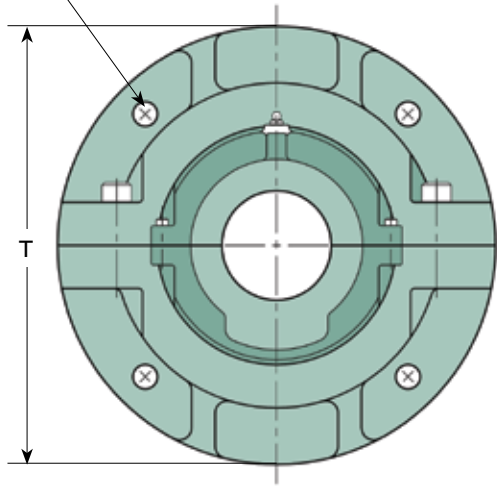

Shaft Diameter d (inches)	Bearing Reference(1)	Reference(1) (flange only)	T(2) (mm)	Bolts			R (mm)	P (mm)	H (mm)	N(3) (mm)	V(3) (mm)	L(4) (mm)	Mass (flange only) (kg)
				No.	Metric Size	Inch Size							
1 ³ / ₁₆	01 B 103	F01	204	4	M12	½"	164	13	51	119.06	3	94	4.2
1 ^¼	01 B 104	F01	204	4	M12	½"	164	13	51	119.06	3	94	4.2
1 ⁷ / ₁₆	01 B 107	F01	204	4	M12	½"	164	13	51	119.06	3	94	4.2
1 ^½	01 B 108	F01	204	4	M12	½"	164	13	51	119.06	3	94	4.2
1 ¹¹ / ₁₆	01E B 111	F02	216	4	M12	½"	180	13	57	136.53	3	106	5.1
1 ^¾	01E B 112	F02	216	4	M12	½"	180	13	57	136.53	3	106	5.1
1 ¹⁵ / ₁₆	01E B 115	F02	216	4	M12	½"	180	13	57	136.53	3	106	5.1
	02 B 115	F03	260	4	M12	½"	218	16	67	166.69	3	124	9.1
2	01E B 200	F02	216	4	M12	½"	180	13	57	136.53	3	106	5.1
	02 B 200	F03	260	4	M12	½"	218	16	67	166.69	3	124	9.1
2 ³ / ₁₆	01E B 203	F03	260	4	M12	½"	218	16	67	166.69	3	119	9.1
	02 B 203	F04	286	4	M12	½"	242	16	73	192.09	3	136	12.4
2 ^¼	01E B 204	F03	260	4	M12	½"	218	16	67	166.69	3	119	9.1
	02 B 204	F04	286	4	M12	½"	242	16	73	192.09	3	136	12.4
2 ⁷ / ₁₆	01E B 207	F03	260	4	M12	½"	218	16	67	166.69	3	119	9.1
	02 B 207	F04	286	4	M12	½"	242	16	73	192.09	3	136	12.4

(1) For full references of bearings and cartridges see page 50

(2) Dimension shown is as-cast dimension. Depending upon manufacturing method used, flanges supplied may be machined 5mm smaller

(3) Dimensions shown are for locating spigot for mounting flange on to. Diameter tolerance of locating spigot: f8

(4) Applies for cartridges with either single seal groove or TL seals

R p.c.d. – holes equally spaced

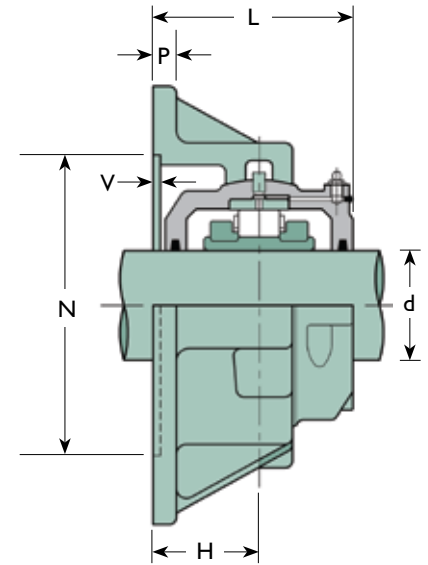
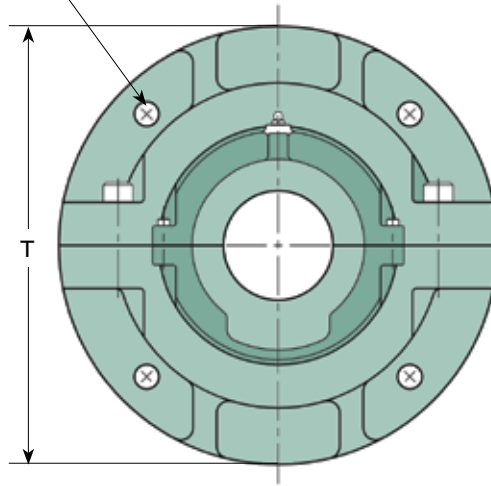

Shaft Diameter d (inches)	Bearing Reference(1)	Reference(1) (flange only)	T(2) (mm)	Bolts			R (mm)	P (mm)	H (mm)	N(3) (mm)	V(3) (mm)	L(4) (mm)	Mass (flange only) (kg)
				No.	Metric Size	Inch Size							
2½	01E B 208	F03	260	4	M12	½"	218	16	67	166.69	3	119	9.1
	02 B 208	F04	286	4	M12	½"	242	16	73	192.09	3	136	12.4
2⅛	01E B 211	F04	286	4	M12	½"	242	16	73	192.09	3	130	12.4
	02 B 211	F04	286	4	M12	½"	242	16	73	192.09	3	130	12.4
2¾	01E B 212	F04	286	4	M12	½"	242	16	73	192.09	3	130	12.4
	02 B 212	F04	286	4	M12	½"	242	16	73	192.09	3	130	12.4
2⅝	100 B 215	F03	260	4	M12	½"	218	16	67	166.69	3	119	9.1
	01E B 215	F04	286	4	M12	½"	242	16	73	192.09	3	130	12.4
	02 B 215	F05	330	4	M16	⅝"	274	19	79	215.90	3	149	19.4
3	100 B 300	F03	260	4	M12	½"	218	16	67	166.69	3	119	9.1
	01E B 300	F04	286	4	M12	½"	242	16	73	192.09	3	130	12.4
	02 B 300	F05	330	4	M16	⅝"	274	19	79	215.90	3	149	19.4
3⅜	01E B 303	F05	330	4	M16	⅝"	274	19	79	215.90	3	147	19.4
	02 B 303	F06	356	4	M16	⅝"	302	19	86	244.48	3	163	22.0
3¼	01E B 304	F05	330	4	M16	⅝"	274	19	79	215.90	3	147	19.4
	02 B 304	F06	356	4	M16	⅝"	302	19	86	244.48	3	163	22.0

(1) For full references of bearings and cartridges see pages 52 and 54

(2) Dimension shown is as-cast dimension. Depending upon manufacturing method used, flanges supplied may be machined 5mm smaller

INCH-SIZE ROUND FLANGE-MOUNTED UNITS FROM 2½" TO 4" BORE SIZE

R p.c.d. – holes equally spaced

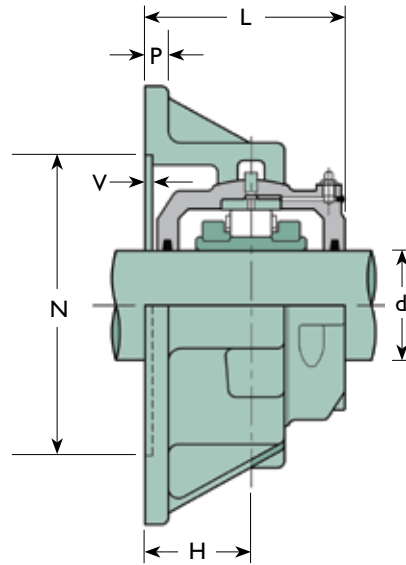
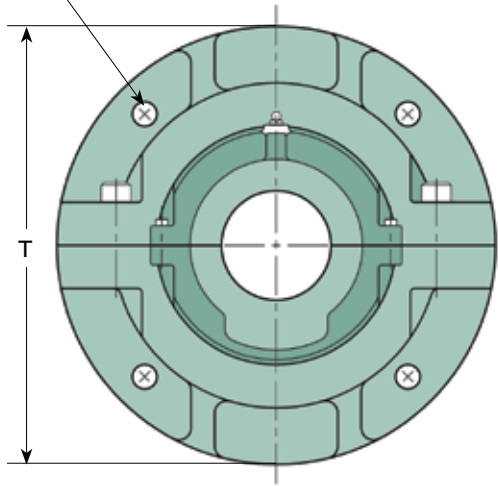

Shaft Diameter d (inches)	Bearing Reference(1)	Reference(1) (flange only)	T(2) (mm)	Bolts			R (mm)	P (mm)	H (mm)	N(3) (mm)	V(3) (mm)	L(4) (mm)	Mass (flange only) (kg)
				No.	Metric Size	Inch Size							
3¼	100 B 307	F04	286	4	M12	½"	242	16	73	192.09	3	130	12.4
	01E B 307	F05	330	4	M16	⅝"	274	19	79	215.90	3	147	19.4
	02 B 307	F06	356	4	M16	⅝"	302	19	86	244.48	3	163	22.0
3½	01E B 308	F05	330	4	M16	⅝"	274	19	79	215.90	3	147	19.4
	02 B 308	F06	356	4	M16	⅝"	302	19	86	244.48	3	163	22.0
3⅞	01E B 311	F06	356	4	M16	⅝"	302	19	86	244.48	3	153	22.0
	02 B 311	F07	382	4	M16	⅝"	334	22	92	276.23	3	165	26.6
3¾	01E B 312	F06	356	4	M16	⅝"	302	19	86	244.48	3	153	22.0
	02 B 312	F07	382	4	M16	⅝"	334	22	92	276.23	3	165	26.6
3⅝	100 B 315	F05	330	4	M16	⅝"	274	19	79	215.90	3	147	19.4
	01E B 315	F06	356	4	M16	⅝"	302	19	86	244.48	3	153	22.0
	02 B 315	F07	382	4	M16	⅝"	334	22	92	276.23	3	165	26.6
4	100 B 400	F05	330	4	M16	⅝"	274	19	79	215.90	3	147	19.4
	01E B 400	F06	356	4	M16	⅝"	302	19	86	244.48	3	153	22.0
	02 B 400	F07	382	4	M16	⅝"	334	22	92	276.23	3	165	26.6

(3) Dimensions shown are for locating spigot for mounting flange on to. Diameter tolerance of locating spigot: f8

(4) Applies for cartridges with either single seal groove or TL seals

R p.c.d. – holes equally spaced

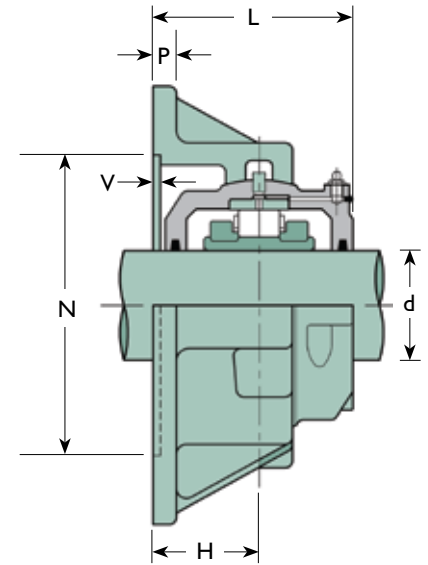
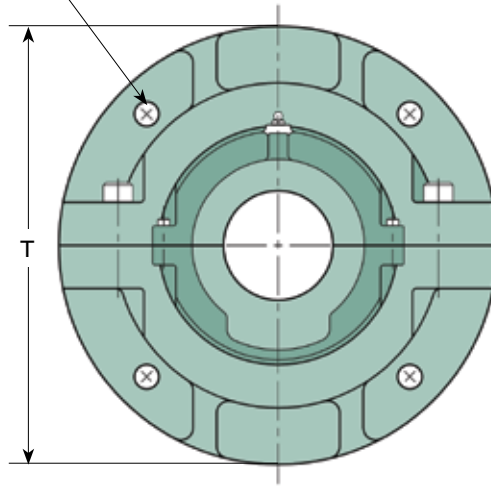

Shaft Diameter d (inches)	Bearing Reference(1)	Reference(1) (flange only)	T(2) (mm)	Bolts			R (mm)	P (mm)	H (mm)	N(3) (mm)	V(3) (mm)	L(4) (mm)	Mass (flange only) (kg)
				No.	Metric Size	Inch Size							
4 ³ / ₁₆	01 B 403	F07	382	4	M16	5/8"	334	22	92	276.23	3	163	26.6
	02 B 403	F08	432	4	M24	1"	374	22	98	314.33	3	179	34.9
4 ⁷ / ₁₆	100 B 407	F06	356	4	M16	5/8"	302	19	86	244.48	3	153	22.0
	01 B 407	F07	382	4	M16	5/8"	334	22	92	276.23	3	163	26.6
	02 B 407	F08	432	4	M24	1"	374	22	98	314.33	3	179	34.9
4 ¹ / ₂	100 B 408	F06	356	4	M16	5/8"	302	19	86	244.48	3	153	22.0
	01 B 408	F07	382	4	M16	5/8"	334	22	92	276.23	3	163	26.6
	02 B 408	F08	432	4	M24	1"	374	22	98	314.33	3	179	34.9
4 ¹⁵ / ₁₆	100 B 415	F07	382	4	M16	5/8"	334	22	92	276.23	3	163	26.6
	01 B 415	F08	432	4	M24	1"	374	22	98	314.33	3	176	34.9
	02 B 415	F10	470	4	M24	1"	412	25	114	346.07	3	206	50.2
5	100 B 500	F07	382	4	M16	5/8"	334	22	92	276.23	3	163	26.6
	01 B 500	F08	432	4	M24	1"	374	22	98	314.33	3	176	34.9
	02 B 500	F10	470	4	M24	1"	412	25	114	346.07	3	206	50.2
5 ³ / ₁₆	01 B 503	F09	444	4	M24	1"	384	25	98	317.50	3	182	40.8
	02 B 503	F30	508	4	M24	1"	444	25	114	377.82	3	208	67

(1) For full references of bearings and cartridges see pages 56 and 58

(2) Dimension shown is as-cast dimension. Depending upon manufacturing method used, flanges supplied may be machined 5mm smaller

INCH-SIZE ROUND FLANGE-MOUNTED UNITS FROM 4³/₁₆" TO 6" BORE SIZE

R p.c.d. – holes equally spaced

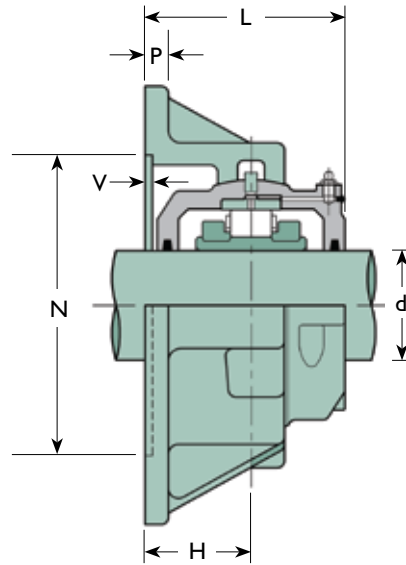
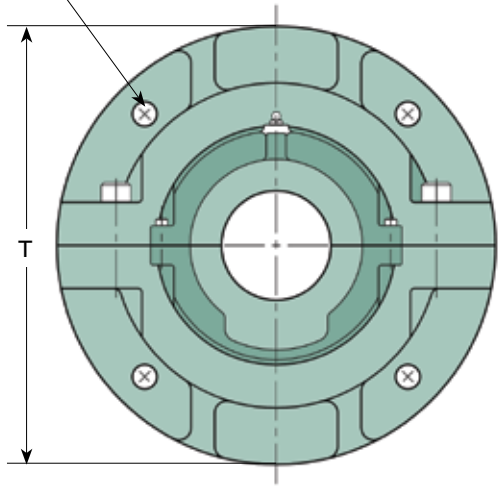

Shaft Diameter d (inches)	Bearing Reference(1)	Reference(1) (flange only)	T(2) (mm)	Bolts			R (mm)	P (mm)	H (mm)	N(3) (mm)	V(3) (mm)	L(4) (mm)	Mass (flange only) (kg)
				No.	Metric Size	Inch Size							
5 ¹ / ₁₆	100 B 507	F08	432	4	M24	1"	374	22	98	314.33	3	176	34.9
	01 B 507	F09	444	4	M24	1"	384	25	98	317.50	3	182	40.8
	02 B 507	F30	508	4	M24	1"	444	25	114	377.82	3	208	67
5 ¹ / ₂	100 B 508	F08	432	4	M24	1"	374	22	98	314.33	3	176	34.9
	01 B 508	F09	444	4	M24	1"	384	25	98	317.50	3	182	40.8
	02 B 508	F30	508	4	M24	1"	444	25	114	377.82	3	208	67
5 ¹⁵ / ₁₆	100 B 515	F09	444	4	M24	1"	384	25	98	317.50	3	182	40.8
	01 B 515	F10	470	4	M24	1"	412	25	114	346.07	3	201	50.2
	02 B 515	F31	534	4	M24	1"	466	25	124	393.70	3	226	81
6	100 B 600	F09	444	4	M24	1"	384	25	98	317.50	3	182	40.8
	01 B 600	F10	470	4	M24	1"	412	25	114	346.07	3	201	50.2
	02 B 600	F31	534	4	M24	1"	466	25	124	393.70	3	226	81

(3) Dimensions shown are for locating spigot for mounting flange on to. Diameter tolerance of locating spigot: f8

(4) Applies for cartridges with either single seal groove or TL seals

R pcd – holes equally spaced

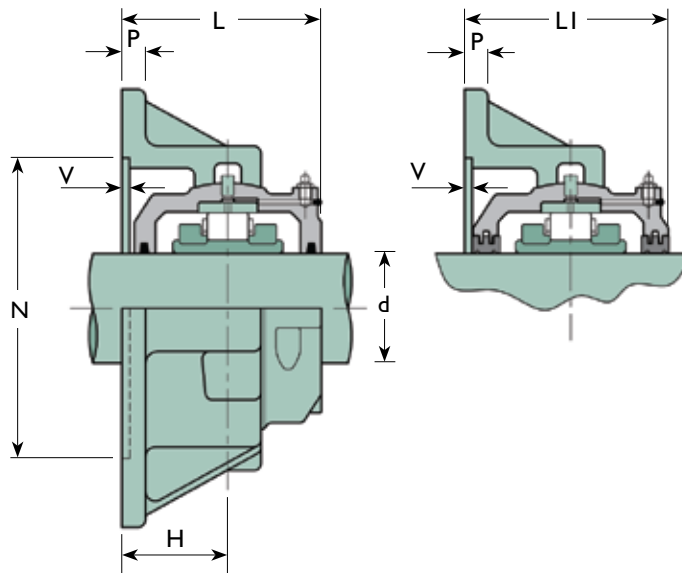
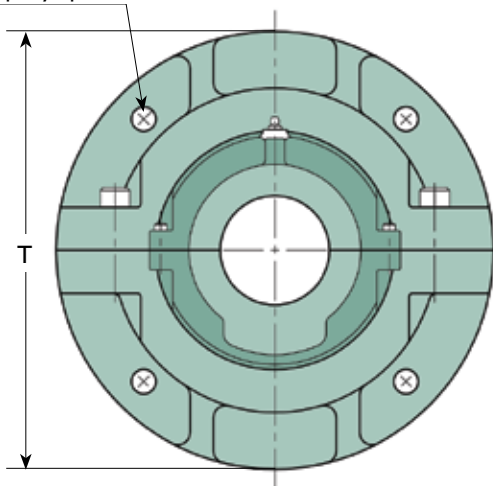

Shaft Diameter d (inches)	Bearing Reference(1)	Reference(1) (flange only)	T(2) (mm)	Bolts			R (mm)	P (mm)	H (mm)	N(3) (mm)	V(3) (mm)	L(4) (mm)	L1 (mm)	Mass (flange only) (kg)
				No.	Metric Size	Inch Size								
6 ⁷ / ₁₆	01 B 607	F11	496	4	M24	1"	426	25	105	352.43	3	191	201	58
	02 B 607	F32	584	4	M30	1 ¹ / ₄ "	508	29	124	428.63	5	227	240	95
6 ¹ / ₂	01 B 608	F11	496	4	M24	1"	426	25	105	352.43	3	191	201	58
	02 B 608	F32	584	4	M30	1 ¹ / ₄ "	508	29	124	428.63	5	227	240	95
6 ¹⁵ / ₁₆	01 B 615	F12	508	4	M24	1"	438	29	108	365.13	3	194	208	62
	02 B 615	F33	596	4	M30	1 ¹ / ₄ "	524	32	130	444.50	5	241	251	100
7	01 B 700	F12	508	4	M24	1"	438	29	108	365.13	3	194	208	62
	02 B 700	F33	596	4	M30	1 ¹ / ₄ "	524	32	130	444.50	5	241	251	100
7 ¹⁵ / ₁₆	01 B 715	F13	534	4	M24	1"	474	32	108	400.05	3	194	208	71
	02 B 715	F34	648	4	M30	1 ¹ / ₄ "	572	32	137	492.13	5	255	266	138
8	01 B 800	F13	534	4	M24	1"	474	32	108	400.05	3	194	208	71
	02 B 800	F34	648	4	M30	1 ¹ / ₄ "	572	32	137	492.13	5	255	266	138
9	01 B 900	F14	584	4	M30	1 ¹ / ₄ "	512	35	117	431.80	3	206	225	85
	02 B 900	F35	712	4	M36	1 ¹ / ₂ "	620	35	146	527.05	5	267	283	145

(1) For full references of bearings and cartridges see pages 60 to 64

(2) Dimension shown is as-cast dimension. Depending upon manufacturing method used, flanges supplied may be machined 5mm smaller

INCH-SIZE ROUND FLANGE-MOUNTED UNITS FROM 6⁷/₁₆" TO 16" BORE SIZE

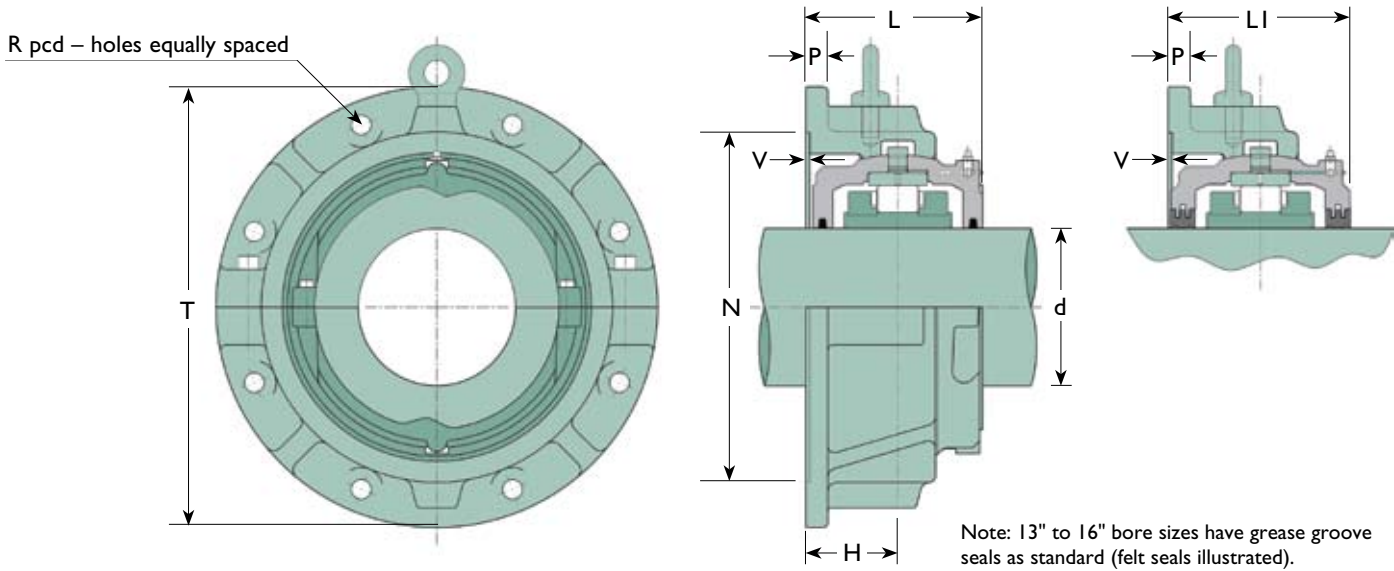

Shaft Diameter d (inches)	Bearing Reference(1)	Reference(1) (flange only)	T(2) (mm)	Bolts			R (mm)	P (mm)	H (mm)	N(3) (mm)	V(3) (mm)	L(4) (mm)	LI (mm)	Mass (flange only) (kg)
				No.	Metric Size	Inch Size								
10	01 B 1000	F15	610	4	M30	1¼"	542	35	117	463.55	3	211	228	100
	02 B 1000	F36	736	4	M36	1½"	660	38	149	568.33	5	273	289	178
11	01 B 1100	F16	660	4	M30	1¼"	584	38	124	504.83	3	226	240	116
	02 B 1100	F37	762	8	M30	1¼"	682	38	159	603.25	5	291	309	195
12	01 B 1200	F17	712	4	M30	1¼"	626	38	133	539.75	3	241	257	119
	02 B 1200	F38	788	8	M30	1¼"	708	41	162	628.65	5	296	315	195
13	01 B 1300	F18	812	4	M36	1½"	698	38	152	584.20	5	282	288	184
	02 B 1300	F39	914	8	M30	1¼"	800	45	190	680.00	7	339	355	309
14	01 B 1400	F19	850	4	M36	1½"	738	40	140	610.00	7	270	276	207
15	01 B 1500	F20	914	8	M30	1¼"	800	44	165	673.10	5	295	305	276
16	01 B 1600	F21	914	8	M30	1¼"	800	44	165	673.10	5	305	308	273

(3) Dimensions shown are for locating spigot for mounting flange on to. Diameter tolerance of locating spigot: f8

METRIC SQUARE FLANGE-MOUNTED UNITS

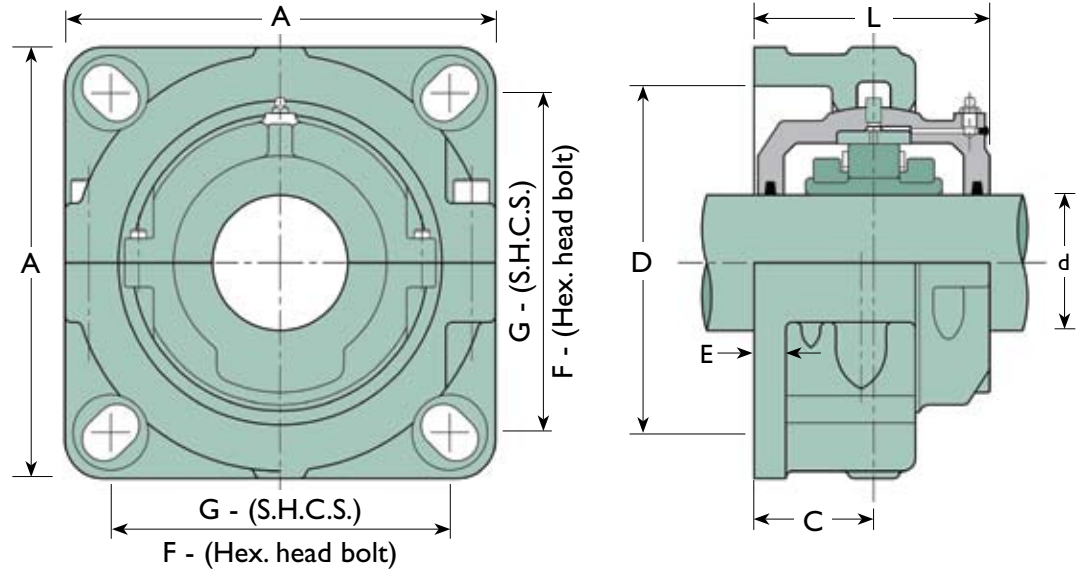

Shaft Diameter d (mm)	Bearing Reference(1)	Reference(1) (flange only)	A (mm)	SHCS		Hex. Head Bolt		C (mm)	D (mm)	E (mm)	L(2) (mm)	Mass (flange only) (kg)
				Size	G centres (mm)	Size	F centres (mm)					
45	01E B 45M	DF02	165	M12	114	½"	118	52	120	13	101	4.0
50	01E B 50M	DF02	165	M12	114	½"	118	52	120	13	101	4.0
55	01E B 55M	DF03	184	M16	136	⅝"	141	55	146	16	107	5.6
60	01E B 60M	DF03	184	M16	136	⅝"	141	55	146	16	107	5.6
65	01E B 65M	DF03	184	M16	136	⅝"	141	55	146	16	107	5.6
70	01E B 70M	DF04	217	M20	164	¾"	171	60	178	16	117	8.5
75	100 B 75M	DF03	184	M16	136	⅝"	141	55	146	16	107	5.6
	01E B 75M	DF04	217	M20	164	¾"	171	60	178	16	117	8.5
85	100 B 85M	DF04	217	M20	164	¾"	171	60	178	16	117	8.5

(1) For full references of bearings and cartridges see pages 30 and 32

(2) Applies for cartridges with either single seal groove or TL seals

INCH-SIZE SQUARE FLANGE-MOUNTED UNITS

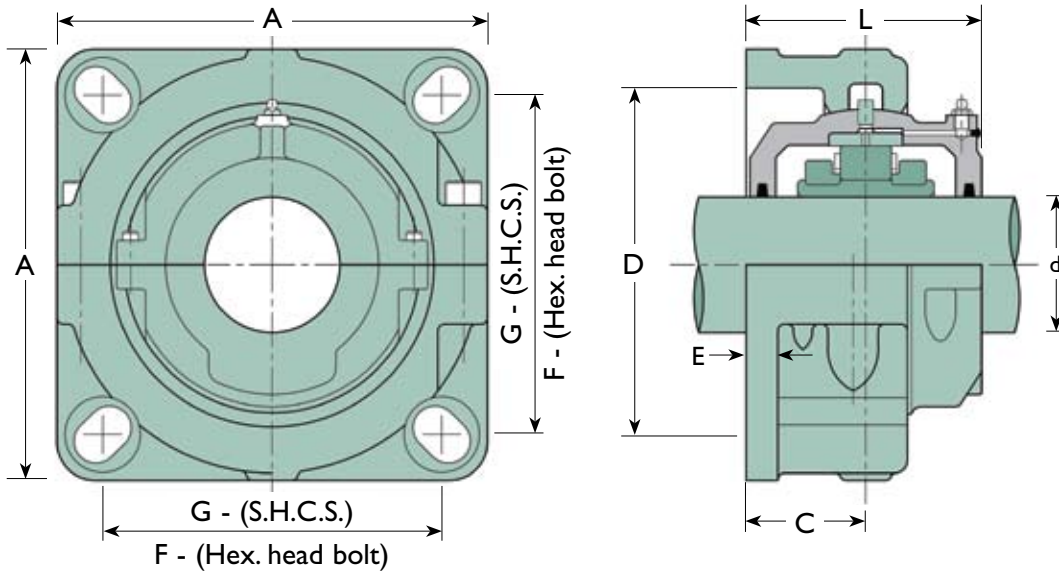

Shaft Diameter d (inches)	Bearing Reference(1)	Reference(1) (flange only)	A (mm)	SHCS		Hex. Head Bolt		C (mm)	D (mm)	E (mm)	L(2) (mm)	Mass (flange only) (kg)
				Size	G centres (mm)	Size	F centres (mm)					
1 ¹ / ₁₆	01E B 111	DF02	165	M12	114	½"	118	52	120	13	101	4.0
1 ³ / ₁₆	01E B 112	DF02	165	M12	114	½"	118	52	120	13	101	4.0
1 ⁵ / ₁₆	01E B 115	DF02	165	M12	114	½"	118	52	120	13	101	4.0
2	01E B 200	DF02	165	M12	114	½"	118	52	120	13	101	4.0
2 ³ / ₁₆	01E B 203	DF03	184	M16	136	5/8"	141	55	146	16	107	5.6
2 ¹ / ₄	01E B 204	DF03	184	M16	136	5/8"	141	55	146	16	107	5.6
2 ⁷ / ₁₆	01E B 207	DF03	184	M16	136	5/8"	141	55	146	16	107	5.6
2 ¹ / ₂	01E B 208	DF03	184	M16	136	5/8"	141	55	146	16	107	5.6
2 ¹¹ / ₁₆	01E B 211	DF04	217	M20	164	¾"	171	60	178	16	117	8.5
2 ³ / ₄	01E B 212	DF04	217	M20	164	¾"	171	60	178	16	117	8.5
2 ¹⁵ / ₁₆	100 B 215	DF03	184	M16	136	5/8"	141	55	146	16	107	5.6
	01E B 215	DF04	217	M20	164	¾"	171	60	178	16	117	8.5
3	100 B 300	DF03	184	M16	136	5/8"	141	55	146	16	107	5.6
	01E B 300	DF04	217	M20	164	¾"	171	60	178	16	117	8.5
3 ¹ / ₁₆	100 B 307	DF04	217	M20	164	¾"	171	60	178	16	117	8.5

(1) For full references of bearings and cartridges see pages 50 to 54

(2) Applies for cartridges with either single seal groove or TL seals

Hanger units are a compact means of supporting the shafts of screw conveyors and similar equipment.

The bearing is mounted directly into a split grey iron housing ('hanger') with a threaded boss, to allow suspension from the

STANDARD HANGER

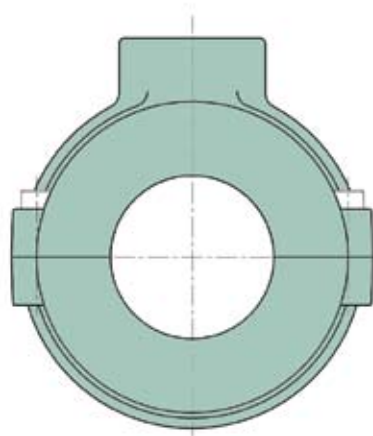

conveyor cross-bracing. A swivel fixing at the cross-bracing joint is recommended to provide for alignment of the bearing.

Hangers are only suitable for housing expansion ('EX') type bearings.

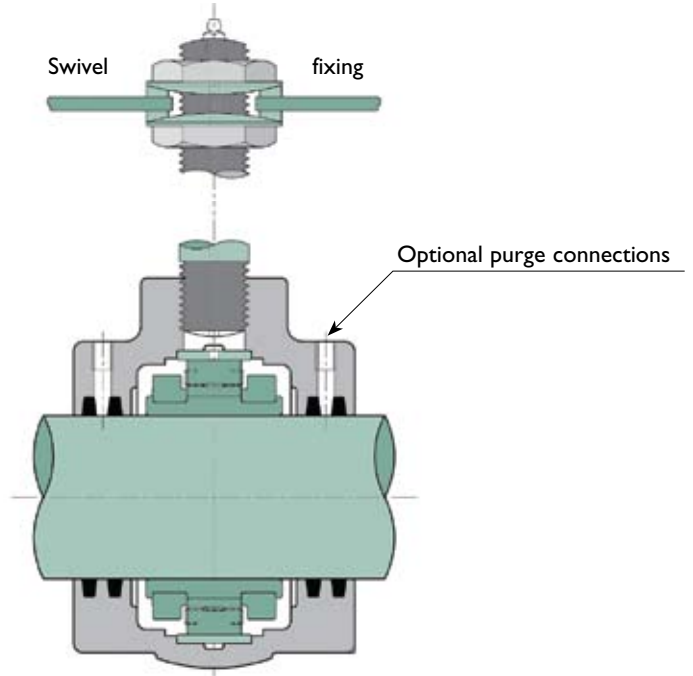

96

Double felt seals are supplied as standard. The standard seal grooves are also able to accommodate rubber lip seals or high temperature packing. A tapped hole in communication with the space between the seal grooves at each end of the housing is optionally provided. This is for connection to either a grease supply or an air supply for regular or continuous purging of the seals.

Another option is for the housing end bores to be machined, to take heavy duty lip seals as illustrated below. The length on shaft of these units may be slightly greater than standard; details will be supplied on request.

HANGER WITH HEAVY DUTY LIP SEALS

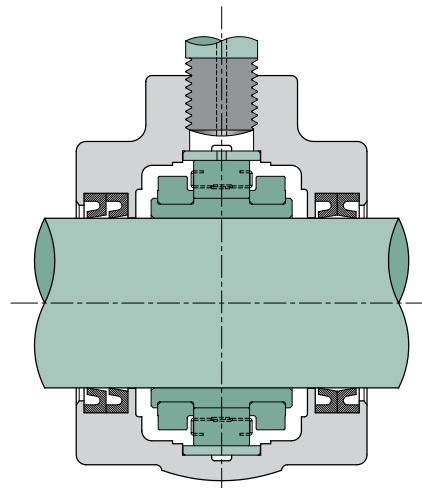

HANGER BEARING UNITS

It is recommended that our technical department is contacted in order to obtain a recommendation for the sealing of each hanger unit application.

Lubrication points are not fitted to hangers as standard, with provision for lubrication of the bearing usually made through the suspension rod. Continuous grease feed is sometimes desirable.

The standard type of hanger has a single threaded boss for suspension from above, by a single rod to minimise the obstruction to material flow in scroll conveyors. For applications where it is desired to locate the housing by rods from above and below, a double boss type is available.

DOUBLE BOSS HANGER

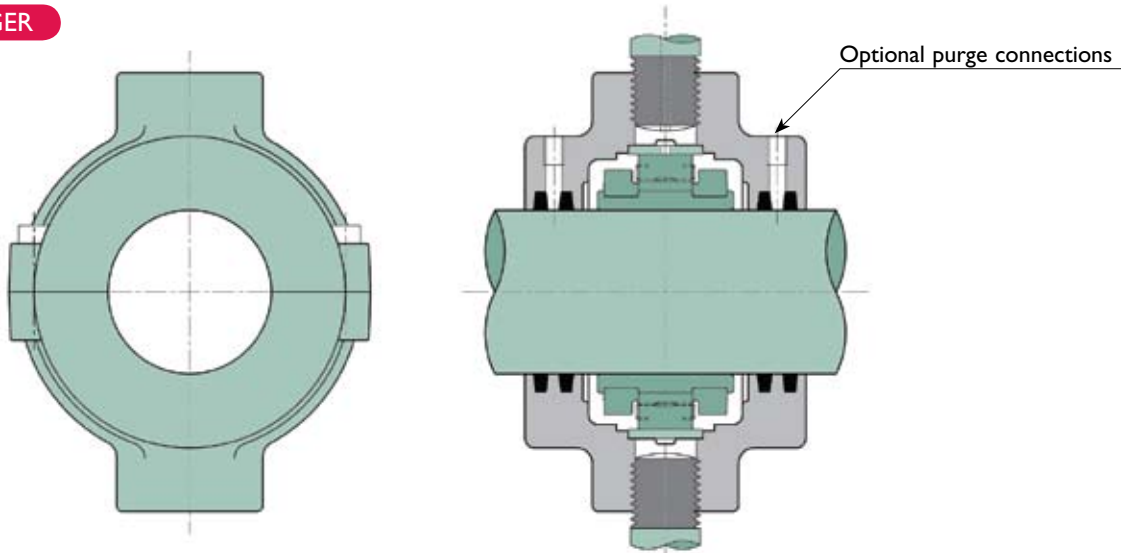

A further type of hanger has three threaded bosses disposed at 120 degree intervals for location by three rods.

TRIPLE BOSS HANGER

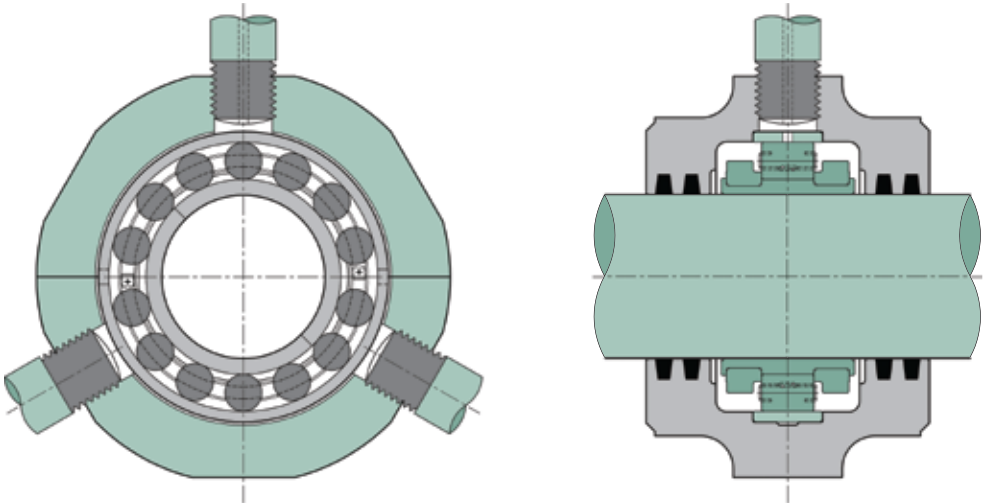

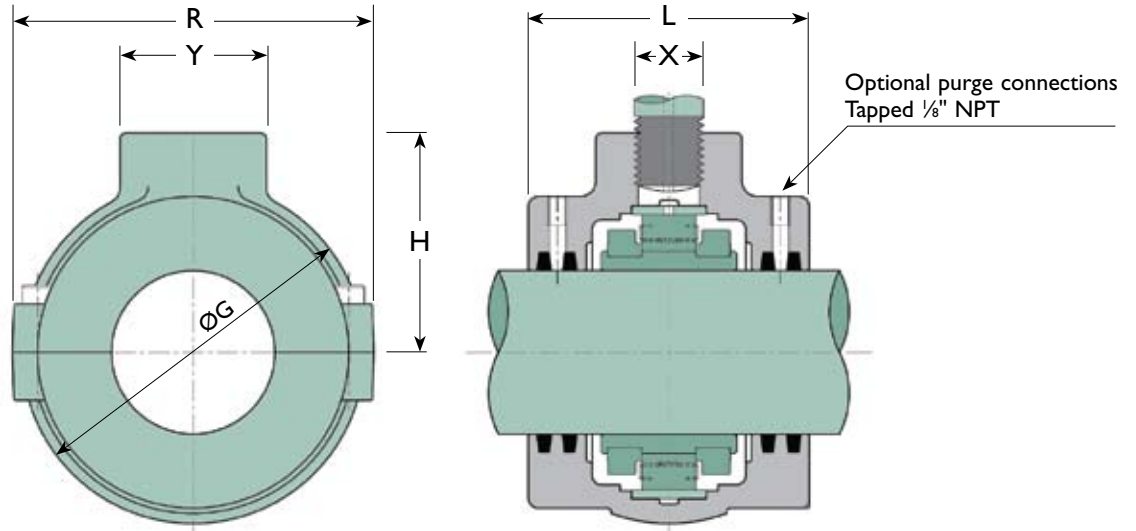

Shaft Diameter d (mm)	Bearing Reference	Hanger Only Reference(I)	G (mm)	L (mm)	H (mm)	X	Y (mm)	R (mm)	Hanger Mass (kg)
40	01 B 40M EX	01 H 40M	100	108	66	M30	50	106	2.6
50	01E B 50M EX	01 H 50M	118	108	76	M30	50	123	4.1
60	01E B 60M EX	01 H 60M	134	108	82	M30	50	139	4.7
65	01E B 65M EX	01 H 65M	134	108	82	M30	50	139	4.7
70	01E B 70M EX	01 H 70M	158	130	92	M30	50	162	8.0
75	100 B 75M EX	100 H 75M	134	108	82	M30	50	139	4.7
	01E B 75M EX	01 H 75M	158	130	92	M30	50	162	8.0
80	01E B 80M EX	01 H 80M	178	146	114	M36	76	188	12.0
85	100 B 85M EX	100 H 85M	158	130	92	M30	50	162	8.0
	01E B 85M EX	01 H 85M	178	146	114	M36	76	188	12.0
90	01E B 90M EX	01 H 90M	178	146	114	M36	76	188	12.0
100	100 B 100M EX	100 H 100M	178	146	114	M36	76	188	12.0
	01E B 100M EX	01 H 100M	203	152	127	M36	76	204	14.0

METRIC HANGER BEARING UNITS

Double Boss

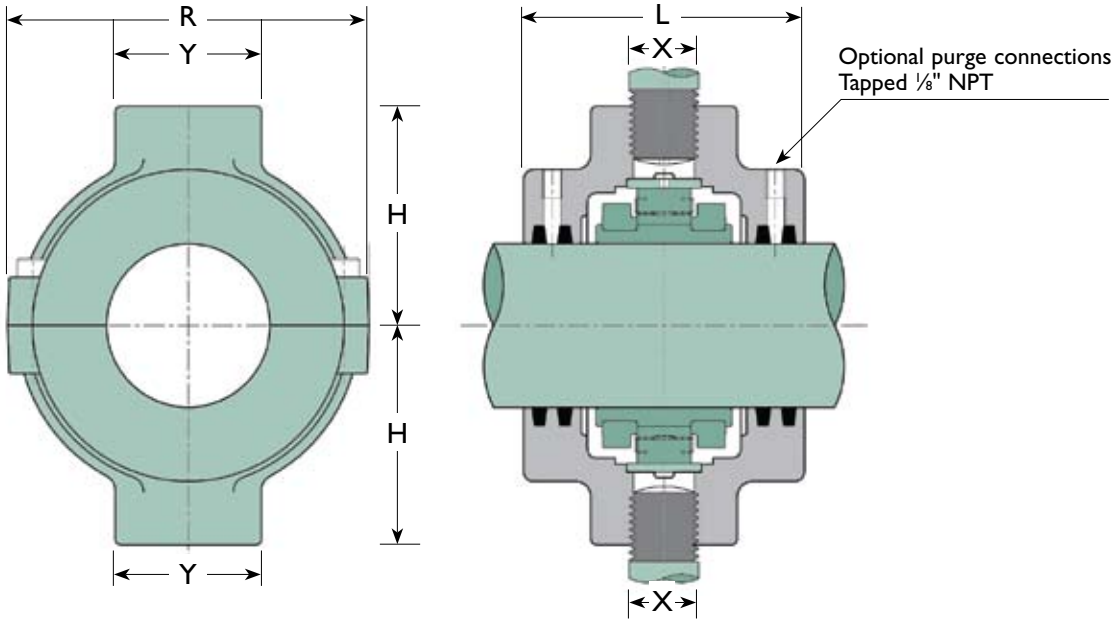

Shaft Diameter d (mm)	Bearing Reference	Hanger Only Reference(I)	G (mm)	L (mm)	H (mm)	X	Y (mm)	R (mm)	Hanger Mass (kg)
105	01E B 105M EX	01E H 105M	203	152	127	M36	76	204	14.0
110	100 B 110M EX	100 H 110M	203	152	127	M36	76	204	14.0
	01 B 110M EX	01 H 110M	232	156	140	M36	76	226	16.4
115	01 B 115M EX	01 H 115M	232	156	140	M36	76	226	16.4
120	100 B 120M EX	100 H 120M	232	156	140	M36	76	226	16.4
	01 B 120M EX	01 H 120M	276	162	156	M36	76	238	22.3
125	01 B 125M EX	01 H 125M	276	162	156	M36	76	238	22.3
130	100 B 130M EX	100 H 130M	232	156	140	M36	76	226	16.4
	01 B 130M EX	01 H 130M	276	162	156	M36	76	238	22.3
135	01 B 135M EX	01 H 135M	280	158	160	M36	76	264	20.9
140	100 B 140M EX	100 H 140M	276	162	156	M36	76	238	22.3
	01 B 140M EX	01 H 140M	280	158	160	M36	76	264	20.9
150	100 B 150M EX	100 H 150M	280	158	160	M36	76	264	20.9

(I) For grease / air purge points to seals add 'AP' to reference, e.g.: 01 H 125M AP

For double boss type add 'DOUBLE BOSS' to reference, e.g.: 01 H 125M DOUBLE BOSS

For double boss type with purge points to seals add 'DOUBLE BOSS AP' to reference, e.g.: 01 H 125M DOUBLE BOSS AP

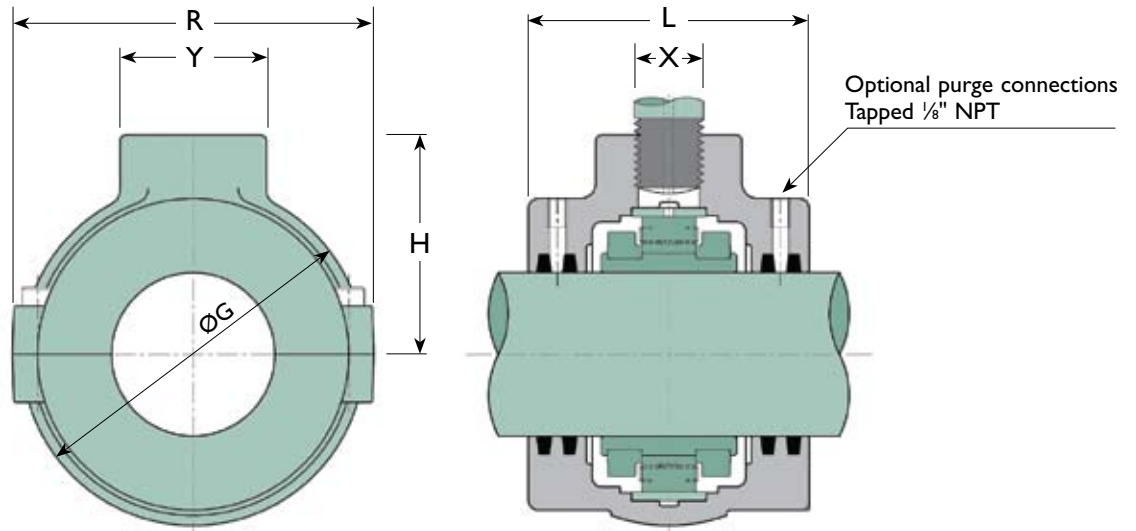

Shaft Diameter d (inches)	Bearing Reference	Hanger Only Reference(1)	G (mm)	L (mm)	H (mm)	X	Y (mm)	R (mm)	Hanger Mass (kg)
1¼"	01 B 104 EX	01 H 104	100	108	66	1" - 8 UNC	50	106	2.6
1½"	01 B 108 EX	01 H 108	100	108	66	1" - 8 UNC	50	106	2.6
1⅞"	01E B 111 EX	01 H 111	118	108	76	1" - 8 UNC	50	123	4.1
1¾"	01E B 112 EX	01 H 112	118	108	76	1" - 8 UNC	50	123	4.1
1⅝"	01E B 115 EX	01 H 115	118	108	76	1" - 8 UNC	50	123	4.1
2	01E B 200 EX	01 H 200	118	108	76	1" - 8 UNC	50	123	4.1
2⅜"	01E B 203 EX	01 H 203	134	108	82	1" - 8 UNC	50	139	4.7
2¼"	01E B 204 EX	01 H 204	134	108	82	1" - 8 UNC	50	139	4.7
2⅞"	01E B 207 EX	01 H 207	134	108	82	1" - 8 UNC	50	139	4.7
2½"	01E B 208 EX	01 H 208	134	108	82	1" - 8 UNC	50	139	4.7
2⅞"	01E B 211 EX	01 H 211	158	130	92	1" - 8 UNC	50	162	8.0
2¾"	01E B 212 EX	01 H 212	158	130	92	1" - 8 UNC	50	162	8.0
2⅝"	100 B 215 EX	100 H 215	134	108	82	1" - 8 UNC	50	139	4.7
	01E B 215 EX	01 H 215	158	130	92	1" - 8 UNC	50	162	8.0

INCH-SIZE HANGER BEARING UNITS TO 4³/₁₆" BORE SIZE

Double Boss

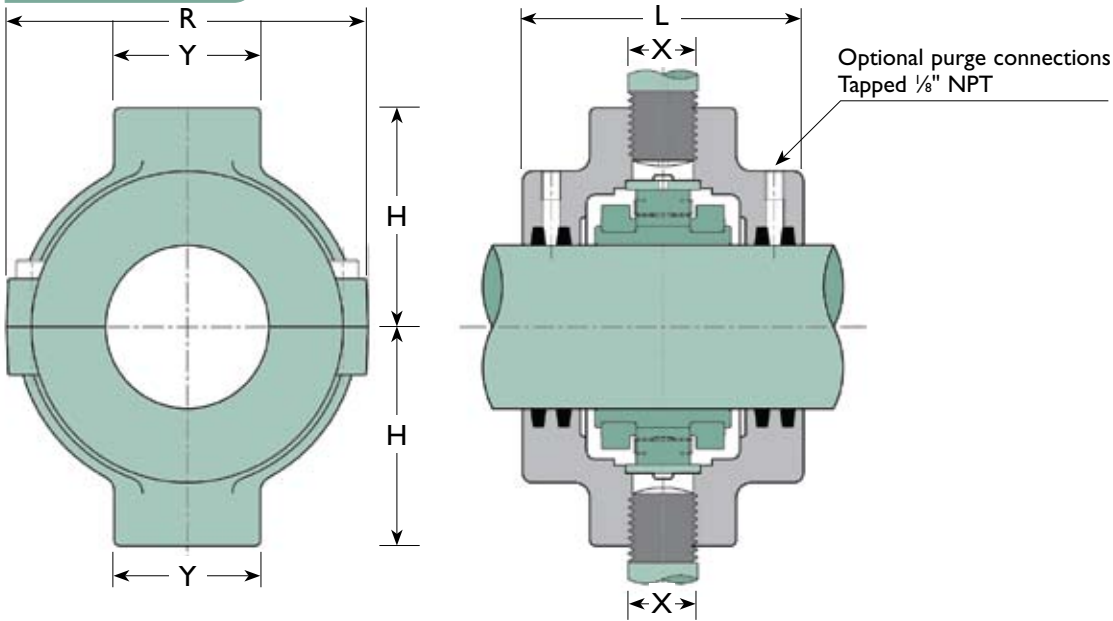

Shaft Diameter d (mm)	Bearing Reference	Hanger Only Reference(1)	G (mm)	L (mm)	H (mm)	X	Y (mm)	R (mm)	Hanger Mass (kg)
3	100 B 300 EX	100 H 300	134	108	82	1" - 8 UNC	50	139	4.7
	01E B 300 EX	01 H 300	158	130	92	1" - 8 UNC	50	162	8.0
3 ³ / ₁₆ "	01E B 303 EX	01 H 303	178	146	114	1 ¹ / ₂ " - 6 UNC	76	188	12.0
3 ¹ / ₄ "	01E B 304 EX	01 H 304	178	146	114	1 ¹ / ₂ " - 6 UNC	76	188	12.0
3 ⁷ / ₁₆ "	100 B 307 EX	100 H 307	158	130	92	1" - 8 UNC	50	162	8.0
	01E B 307 EX	01 H 307	178	146	114	1 ¹ / ₂ " - 6 UNC	76	188	12.0
3 ¹ / ₂ "	01E B 308 EX	01 H 308	178	146	114	1 ¹ / ₂ " - 6 UNC	76	188	12.0
3 ¹¹ / ₁₆ "	01E B 311 EX	01 H 311	203	152	127	1 ¹ / ₂ " - 6 UNC	76	204	14.0
3 ³ / ₄ "	01E B 312 EX	01 H 312	203	152	127	1 ¹ / ₂ " - 6 UNC	76	204	14.0
3 ¹⁵ / ₁₆ "	100 B 315 EX	100 H 315	178	146	114	1 ¹ / ₂ " - 6 UNC	76	188	12.0
	01E B 315 EX	01 H 315	203	152	127	1 ¹ / ₂ " - 6 UNC	76	204	14.0
4	100 B 400 EX	100 H 400	178	146	114	1 ¹ / ₂ " - 6 UNC	76	188	12.0
	01E B 400 EX	01 H 400	203	152	127	1 ¹ / ₂ " - 6 UNC	76	204	14.0
4 ³ / ₁₆ "	01 B 403 EX	01 H 403	232	156	140	1 ¹ / ₂ " - 6 UNC	76	226	16.4

(1) For grease / air purge points to seals add 'AP' to reference, e.g.: 01 H 307 AP

For double boss type add 'DOUBLE BOSS' to reference, e.g.: 01 H 307 DOUBLE BOSS

For double boss type with purge points to seals add 'DOUBLE BOSS AP' to reference, e.g.: 01 H 307 DOUBLE BOSS AP

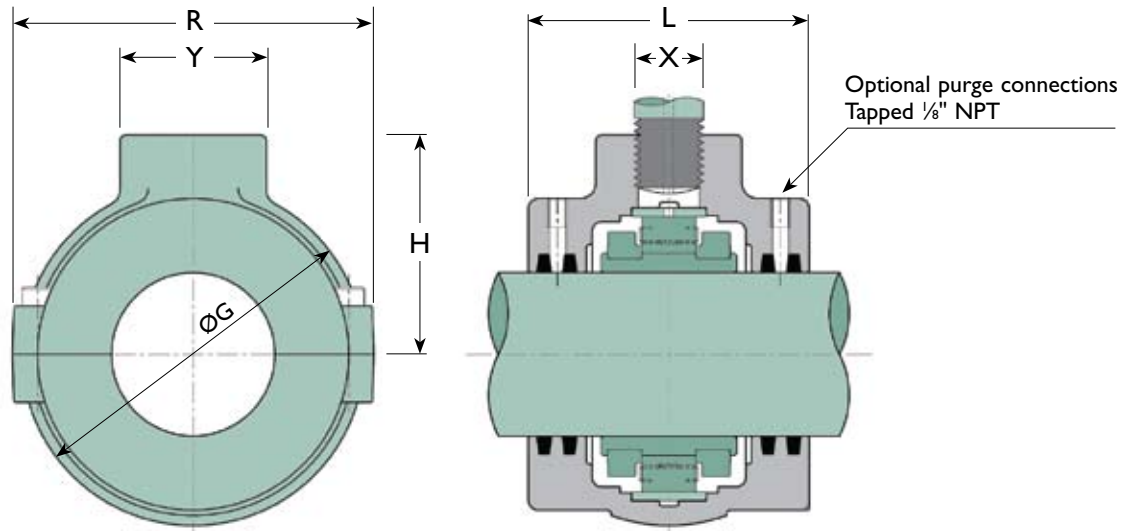

Shaft Diameter d (inches)	Bearing Reference	Hanger Only Reference(I)	G (mm)	L (mm)	H (mm)	X	Y (mm)	R (mm)	Hanger Mass (kg)
4 ¹ / ₁₆ "	100 B 407 EX	100 H 407	203	152	127	1 ¹ / ₂ " - 6 UNC	76	204	14.0
	01 B 407 EX	01 H 407	232	156	140	1 ¹ / ₂ " - 6 UNC	76	226	16.4
4 ¹ / ₂ "	100 B 408 EX	100 H 408	203	152	127	1 ¹ / ₂ " - 6 UNC	76	204	14.0
	01 B 408 EX	01 H 408	232	156	140	1 ¹ / ₂ " - 6 UNC	76	226	16.4
4 ¹⁵ / ₁₆ "	100 B 415 EX	100 H 415	232	156	140	1 ¹ / ₂ " - 6 UNC	76	226	16.4
	01 B 415 EX	01 H 415	276	162	156	1 ¹ / ₂ " - 6 UNC	76	238	22.3
5"	100 B 500 EX	100 H 500	232	156	140	1 ¹ / ₂ " - 6 UNC	76	226	16.4
	01 B 500 EX	01 H 500	276	162	156	1 ¹ / ₂ " - 6 UNC	76	238	22.3
5 ³ / ₁₆ "	01 B 503 EX	01 H 503	280	158	160	1 ¹ / ₂ " - 6 UNC	76	264	20.9
5 ⁷ / ₁₆ "	100 B 507 EX	100 H 507	276	162	156	1 ¹ / ₂ " - 6 UNC	76	238	22.3
	01 B 507 EX	01 H 507	280	158	160	1 ¹ / ₂ " - 6 UNC	76	264	20.9
5 ¹ / ₂ "	100 B 508 EX	100 H 508	276	162	156	1 ¹ / ₂ " - 6 UNC	76	238	22.3
	01 B 508 EX	01 H 508	280	158	160	1 ¹ / ₂ " - 6 UNC	76	264	20.9
5 ¹⁵ / ₁₆ "	100 B 515 EX	100 H 515	280	158	160	1 ¹ / ₂ " - 6 UNC	76	264	20.9
6"	100 B 600 EX	100 H 600	280	158	160	1 ¹ / ₂ " - 6 UNC	76	264	20.9

(I) For grease / air purge points to seals add 'AP' to reference, e.g.: 01 H 407 AP

For double boss type add 'DOUBLE BOSS' to reference, e.g.: 01 H 407 DOUBLE BOSS

For double boss type with purge points to seals add 'DOUBLE BOSS AP' to reference, e.g.: 01 H 407 DOUBLE BOSS AP

INCH-SIZE HANGER BEARING UNITS FROM 4⁷/₁₆" TO 6" BORE SIZE

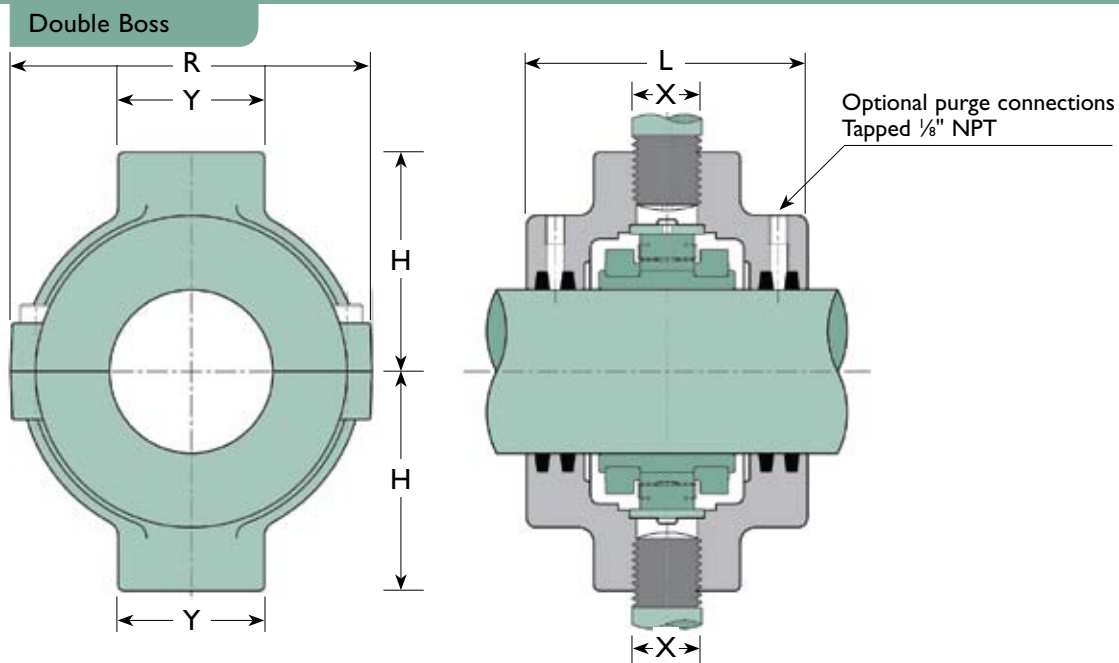

METRIC TRIPLE BOSS HANGER BEARING UNITS

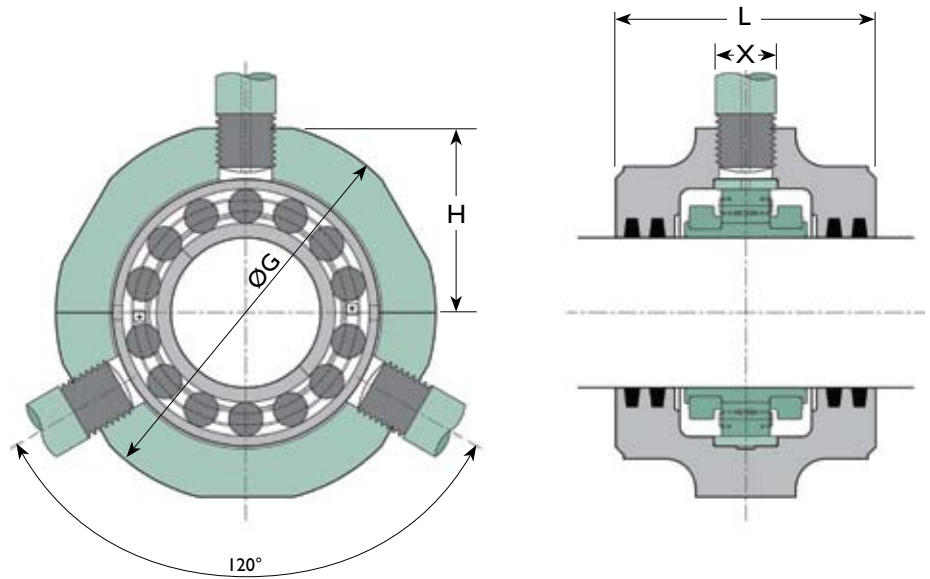

Shaft Diameter d (mm)	Bearing Reference	Hanger Only Reference	G (mm)	L (mm)	H (mm)	X	Hanger Mass (kg)
50mm	01 E B 50M EX	01 H 50M TRIPLE BOSS	160	109	76	M30	6.4
75mm	01E B 75M EX	01 H 75M TRIPLE BOSS	190	130	92	M30	10.0
85mm	100 B 85M EX	100 H 85M TRIPLE BOSS	190	130	92	M30	10.0
110mm	01 B 110M EX	01 H 110M TRIPLE BOSS	290	170	140	M36	30.0
120mm	100 B 120M EX	100 H 120M TRIPLE BOSS	290	170	140	M36	30.0
130mm	100 B 130M EX	100 H 130M TRIPLE BOSS	290	170	140	M36	30.0

INCH-SIZE TRIPLE BOSS HANGER BEARING UNITS

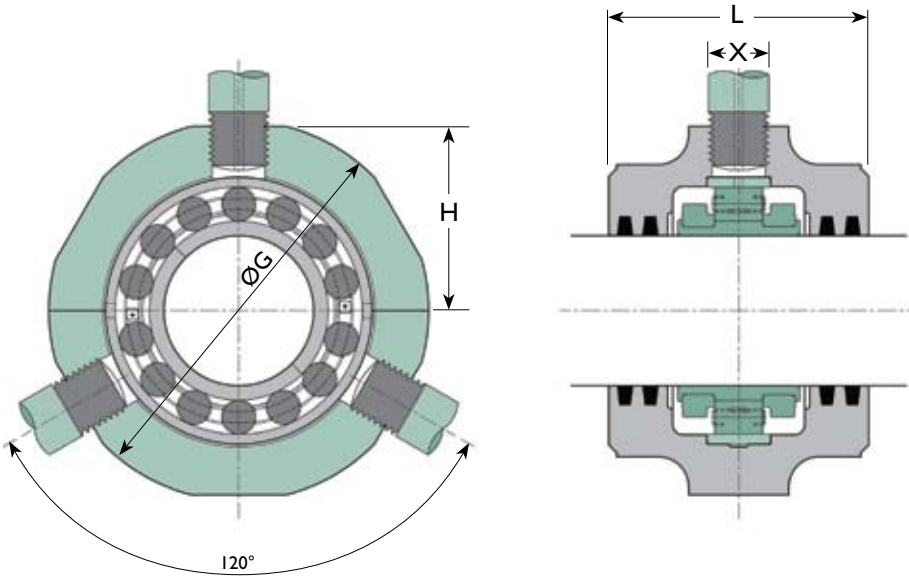

Shaft Diameter d (mm)	Bearing Reference	Hanger Only Reference	G (mm)	L (mm)	H (mm)	X	Hanger Mass (kg)
1 ⁵ / ₁₆ "	01 E B 115 EX	01 H 115 TRIPLE BOSS	160	109	76	1" - 8 UNC	6.4
2"	01 E B 200 EX	01 H 200 TRIPLE BOSS	160	109	76	1" - 8 UNC	6.4
2 ¹ / ₁₆ "	01 E B 215 EX	01 H 215 TRIPLE BOSS	190	130	92	1" - 8 UNC	10.0
3"	01 E B 300 EX	01 H 300 TRIPLE BOSS	190	130	92	1" - 8 UNC	10.0
3 ⁷ / ₁₆ "	100 B 307 EX	100 H 307 TRIPLE BOSS	190	130	92	1" - 8 UNC	10.0
4 ¹ / ₁₆ "	01 B 407 EX	01 H 407 TRIPLE BOSS	290	170	140	1 ¹ / ₂ " - 6 UNC	30.0
4 ¹ / ₂ "	01 B 408 EX	01 H 408 TRIPLE BOSS	290	170	140	1 ¹ / ₂ " - 6 UNC	30.0
4 ¹⁵ / ₁₆ "	100 B 415 EX	100 H 415 TRIPLE BOSS	290	170	140	1 ¹ / ₂ " - 6 UNC	30.0
5"	100 B 500 EX	100 H 500 TRIPLE BOSS	290	170	140	1 ¹ / ₂ " - 6 UNC	30.0

Cooper Take-up units are an efficient means of tensioning the pulleys of conveyors and elevators.

Each take-up unit consists of a Cooper split roller bearing in a swivel cartridge (see page 28) mounted in a cast iron sliding unit. Two basic configurations are available – the 'push' type and 'tension' type as illustrated.

PUSH TYPE TAKE-UP UNIT

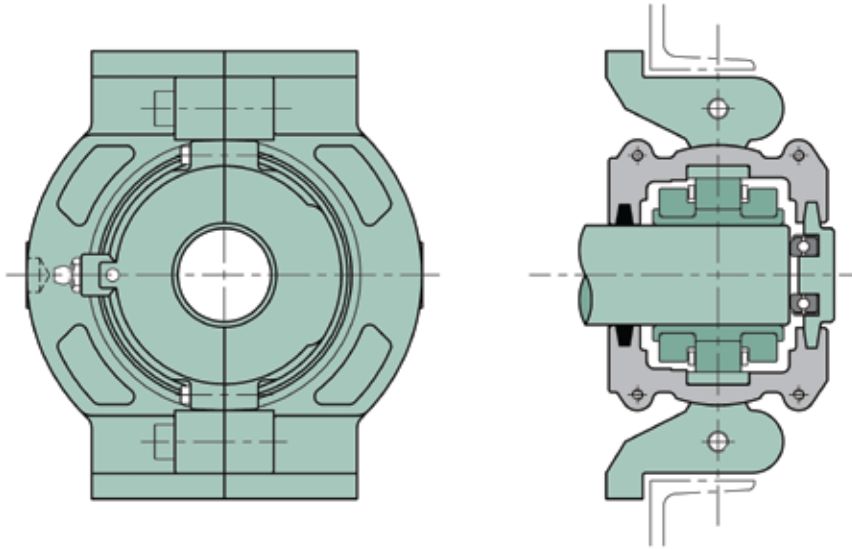

106

TENSIONTYPE TAKE-UP UNIT

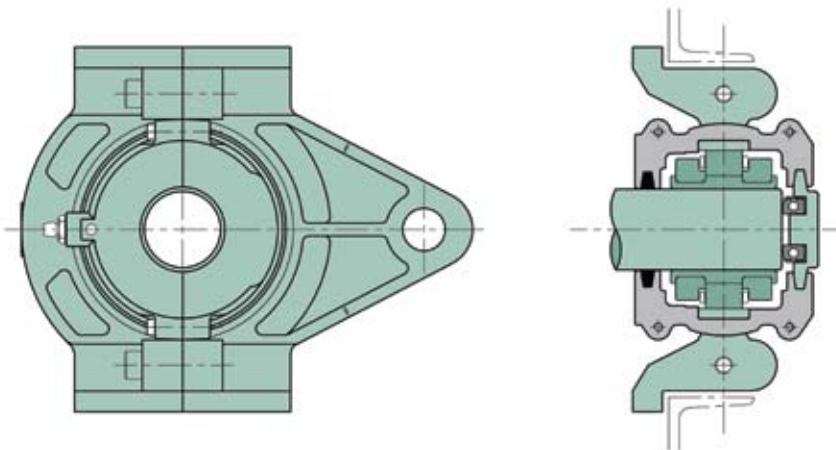

Usually a Cooper take-up will be mounted at each end of the shaft. Up to and including 90mm/3½" bore size the standard arrangement uses two expansion (EX) bearings, with axial location provided by blanking plates and ball thrust bearings.

Above 90mm/3½" bore size the standard arrangement uses two fixed (GR) bearings and plain blanking plates. If a through-shaft or different method of axial location is required, please consult our technical department.

PUSH TYPE UNDER 90mm ARRANGEMENT

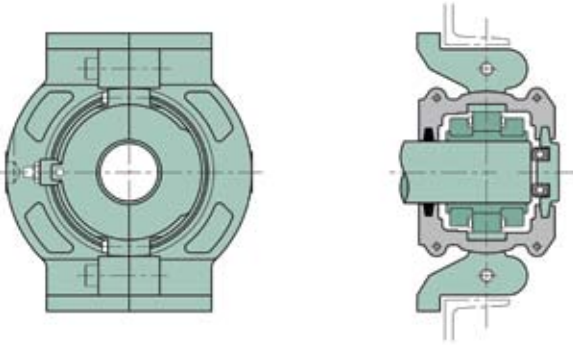

PUSH TYPE OVER 90mm ARRANGEMENT

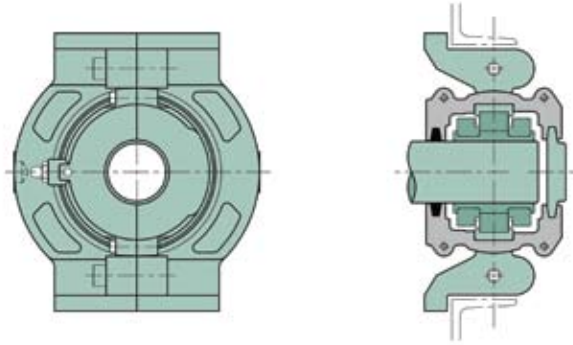

TENSION TYPE UNDER 90mm ARRANGEMENT

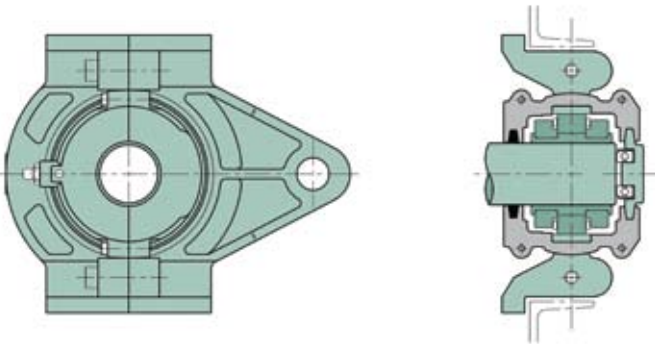

TENSION TYPE OVER 90mm ARRANGEMENT

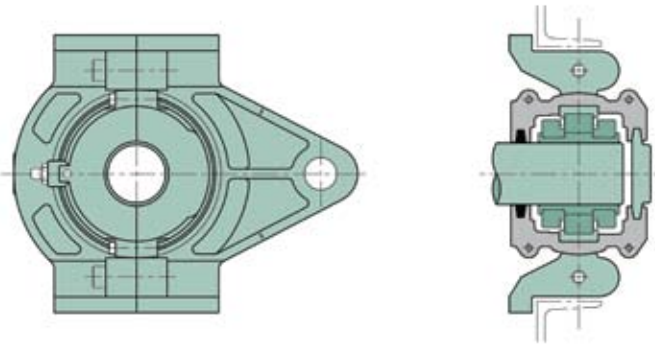

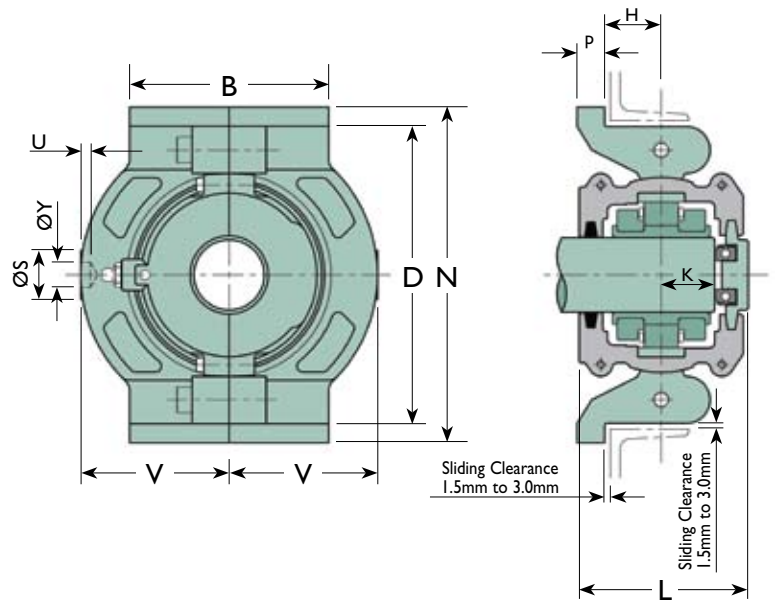

Shaft Diameter d (mm)	References		B (mm)	N (mm)	D (mm)	V (mm)	K (mm)	P (mm)	H (mm)	L (mm)	S (mm)	Y (mm)	U (mm)	Mass (Complete unit) (kg)
	Complete unit (1)	Take-up housing only												
40	01 BCTP 40M	TP01	102	172	153	76	27	14	29	86	25	13	5	6
45	01E BCTP 45M	TP02	114	204	178	88	29	16	29	98	29	13	5	9
50	01E BCTP 50M	TP02	114	204	178	88	29	16	29	98	29	13	5	9
	02 BCTP 50M	TP03	128	235	203	102	35	20	32	114	38	16	6	12
60	01E BCTP 60M	TP03	128	235	203	102	30	20	32	104	38	16	6	13
	02 BCTP 60M	TP04	152	266	229	114	38	22	40	126	41	16	6	17
65	01E BCTP 65M	TP03	128	235	203	102	30	20	32	104	38	16	6	13
	02 BCTP 65M	TP04	152	266	229	114	38	22	40	126	41	16	6	17
70	01E BCTP 70M	TP04	152	266	229	114	35	22	40	114	41	16	6	17
	02 BCTP 70M	TP05	190	318	280	140	41	22	40	140	51	16	6	27
75	100 BCTP 75M	TP03	128	235	203	102	30	20	32	104	38	16	6	13
	01E BCTP 75M	TP04	152	266	229	114	35	22	40	114	41	16	6	17
	02 BCTP 75M	TP05	190	318	280	140	41	22	40	140	51	16	6	27

(1) For radial bearing only reference (for standard arrangement) remove 'CTP' from complete unit reference and add 'EX', e.g. 01E B 60M EX

Ball thrust bearings are usually supplied complete with blanking plate. Refer to page 22

For cartridge reference refer to pages 30 and 32

METRIC TAKE-UP PUSH TYPE UNITS TO 90mm BORE SIZE

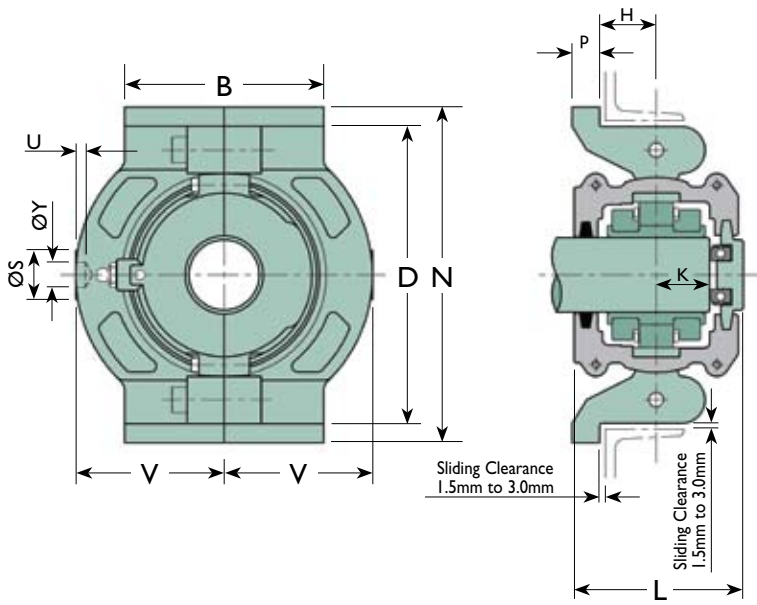

Shaft Diameter d (mm)	References		B (mm)	N (mm)	D (mm)	V (mm)	K (mm)	P (mm)	H (mm)	L (mm)	S (mm)	Y (mm)	U (mm)	Mass (Complete unit) (kg)
	Complete unit (I)	Take-up housing only												
80	01E BCTP 80M	TP05	190	318	280	140	40	22	40	136	51	16	6	27
	02 BCTP 80M	TP06	204	342	305	152	48	22	43	154	51	19	6	31
85	100 BCTP 85M	TP04	152	266	229	114	35	22	40	114	41	16	6	17
	01E BCTP 85M	TP05	190	318	280	140	40	22	40	136	51	16	6	27
	02 BCTP 85M	TP06	204	342	305	152	48	22	43	154	51	19	6	31
90	01E BCTP 90M	TP05	190	318	280	140	40	22	40	136	51	16	6	27
	02 BCTP 90M	TP06	204	342	305	152	48	22	43	154	51	19	6	31

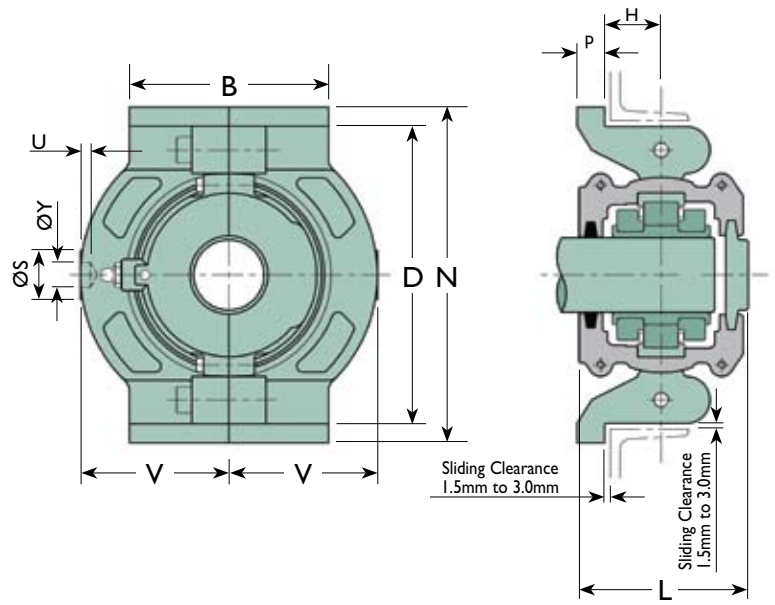

Shaft Diameter d (mm)	References		B (mm)	N (mm)	D (mm)	V (mm)	P (mm)	H (mm)	L (mm)	S (mm)	Y (mm)	U (mm)	Mass (Complete unit) (kg)
	Complete unit (I)	Take-up housing only											
100	100 BCTP 100M	TP05	190	318	280	140	22	40	136	51	16	6	26
	01E BCTP 100M	TP06	204	342	305	152	22	43	134	51	19	6	31
	02 BCTP 100M	TP07	216	382	343	162	22	48	146	70	19	6	46
105	01E BCTP 105M	TP06	204	342	305	152	22	43	134	51	19	6	31
	02 BCTP 105M	TP07	216	382	343	162	22	48	146	70	19	6	46
110	100 BCTP 110M	TP06	204	342	305	152	22	43	134	51	19	6	29
	01 BCTP 110M	TP07	216	382	343	162	22	48	142	70	19	6	46
	02 BCTP 110M	TP08	254	420	381	190	25	51	162	76	19	6	65
115	01 BCTP 115M	TP07	216	382	343	162	22	48	142	70	19	6	46
	02 BCTP 115M	TP08	254	420	381	190	25	51	162	76	19	6	65
120	100 BCTP 120M	TP07	216	382	343	162	22	48	142	70	19	6	42
	01 BCTP 120M	TP08	254	420	381	190	25	51	156	76	19	6	65
	02 BCTP 120M	TP10	266	464	426	204	25	57	184	86	23	8	91
125	01 BCTP 125M	TP08	254	420	381	190	25	51	156	76	19	6	65
	02 BCTP 125M	TP10	266	464	426	204	25	57	184	86	23	8	91

(I) For bearing only reference (for standard arrangement) remove 'CTP' from complete unit reference and add 'GR', e.g. 01 B 110M GR

For cartridge reference refer to pages 32 and 36

METRIC TAKE-UP PUSH TYPE UNITS OVER 90mm BORE SIZE

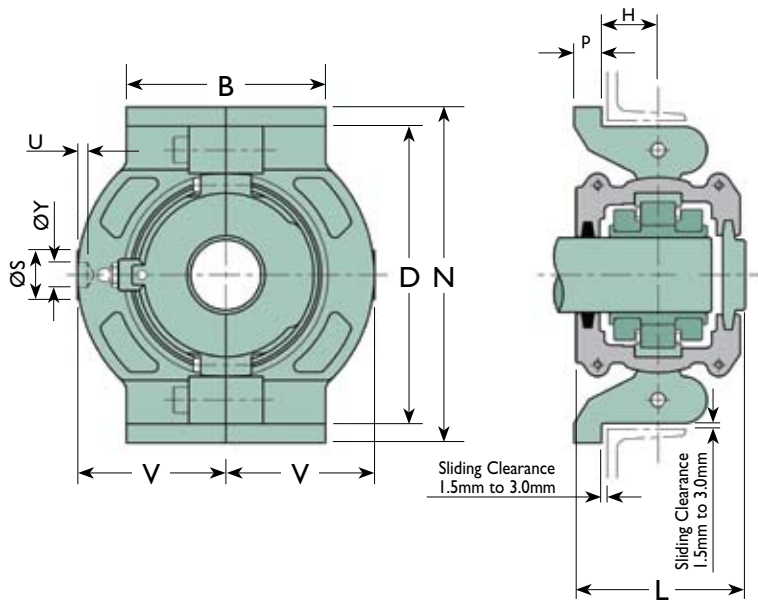

Shaft Diameter d (mm)	References		B (mm)	N (mm)	D (mm)	V (mm)	P (mm)	H (mm)	L (mm)	S (mm)	Y (mm)	U (mm)	Mass (Complete unit) (kg)
	Complete unit (I)	Take-up housing only											
130	100 BCTP 130M	TP07	216	382	343	162	22	48	142	70	19	6	42
	01 BCTP 130M	TP08	254	420	381	190	25	51	156	76	19	6	65
	02 BCTP 130M	TP10	266	464	426	204	25	57	184	86	23	8	91
135	01 BCTP 135M	TP09	266	438	400	196	25	54	168	76	23	8	80
	02 BCTP 135M	TP30	280	502	464	222	25	60	188	92	23	8	109
140	100 BCTP 140M	TP08	254	420	381	190	25	51	156	76	19	6	60
	01 BCTP 140M	TP09	266	438	400	196	25	54	168	76	23	8	80
	02 BCTP 140M	TP30	280	502	464	222	25	60	188	92	23	8	109
150	100 BCTP 150M	TP09	266	438	400	196	25	54	168	76	23	8	73
	01 BCTP 150M	TP10	266	464	426	204	25	57	174	86	23	8	91
	02 BCTP 150M	TP31	305	528	489	235	25	64	204	92	26	10	109
155	01 BCTP 155M	TP10	266	464	426	204	25	57	174	86	23	8	91
	02 BCTP 155M	TP31	305	528	489	235	25	64	204	92	26	10	109

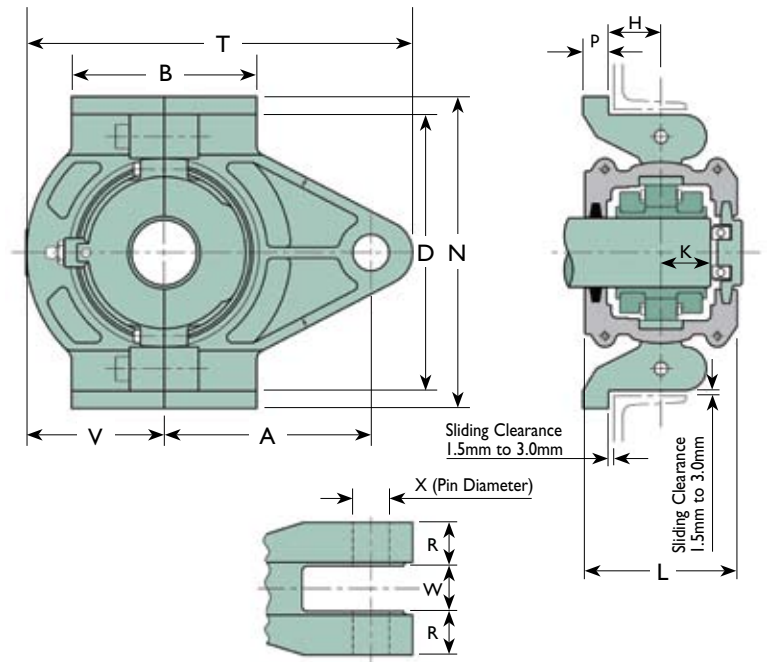

Shaft Diameter d (mm)	References		B (mm)	N (mm)	D (mm)	A (mm)	T (mm)	X (mm)	V (mm)	K (mm)	P (mm)	H (mm)	W (mm)	R (mm)	L (mm)	Mass (Complete unit) (kg)
	Complete unit (1)	Take-up housing only														
40	01 BCTT 40M	TT01	102	172	153	114	216	20	76	27	14	29	25	24	86	7
45	01E BCTT 45M	TT02	114	204	178	128	242	24	88	29	16	29	25	25	98	10
50	01E BCTT 50M	TT02	114	204	178	128	242	24	88	29	16	29	25	25	98	10
	02 BCTT 50M	TT03	128	235	203	146	280	24	102	35	20	32	30	29	114	13
60	01E BCTT 60M	TT03	128	235	203	146	280	24	102	30	20	32	30	29	104	13
	02 BCTT 60M	TT04	152	266	229	158	305	24	114	38	22	40	30	32	126	19
65	01E BCTT 65M	TT03	128	235	203	146	280	24	102	30	20	32	30	29	104	13
	02 BCTT 65M	TT04	152	266	229	158	305	24	114	38	22	40	30	32	126	19
70	01E BCTT 70M	TT04	152	266	229	158	305	24	114	35	22	40	30	32	114	19
	02 BCTT 70M	TT05	190	318	280	190	368	30	140	41	22	40	38	35	140	30

(1) For radial bearing only reference (for standard arrangement) remove 'CTT' from complete unit reference and add 'EX', e.g. 01E B 60M EX

Ball thrust bearings are usually supplied complete with blanking plate. Refer to page 22

For cartridge reference refer to pages 30 and 32

METRIC TAKE-UP TENSION TYPE UNITS TO 90mm BORE SIZE

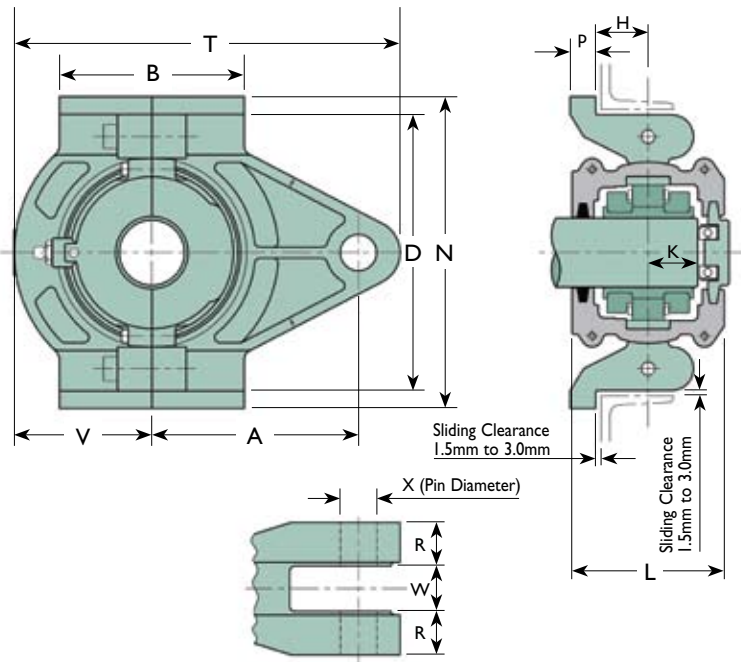

Shaft Diameter d (mm)	References		B (mm)	N (mm)	D (mm)	A (mm)	T (mm)	X (mm)	V (mm)	K (mm)	P (mm)	H (mm)	W (mm)	R (mm)	L (mm)	Mass (Complete unit) (kg)
	Complete unit (I)	Take-up housing only														
75	100 BCTT 75M	TT03	128	235	203	146	280	24	102	30	20	32	30	29	104	13
	01E BCTT 75M	TT04	152	266	229	158	305	24	114	35	22	40	30	32	114	19
	02 BCTT 75M	TT05	190	318	280	190	368	30	140	41	22	40	38	35	140	30
80	01E BCTT 80M	TT05	190	318	280	190	368	30	140	40	22	40	38	35	136	30
	02 BCTT 80M	TT06	204	342	305	210	414	36	152	48	22	43	44	35	154	34
85	100 BCTT 85M	TT04	152	266	229	158	305	24	114	35	22	40	30	32	114	19
	01E BCTT 85M	TT05	190	318	280	190	368	30	140	40	22	40	38	35	136	30
	02 BCTT 85M	TT06	204	342	305	210	414	36	152	48	22	43	44	35	154	34
90	01E BCTT 90M	TT05	190	318	280	190	368	30	140	40	22	40	38	35	136	30
	02 BCTT 90M	TT06	204	342	305	210	414	36	152	48	22	43	44	35	154	34

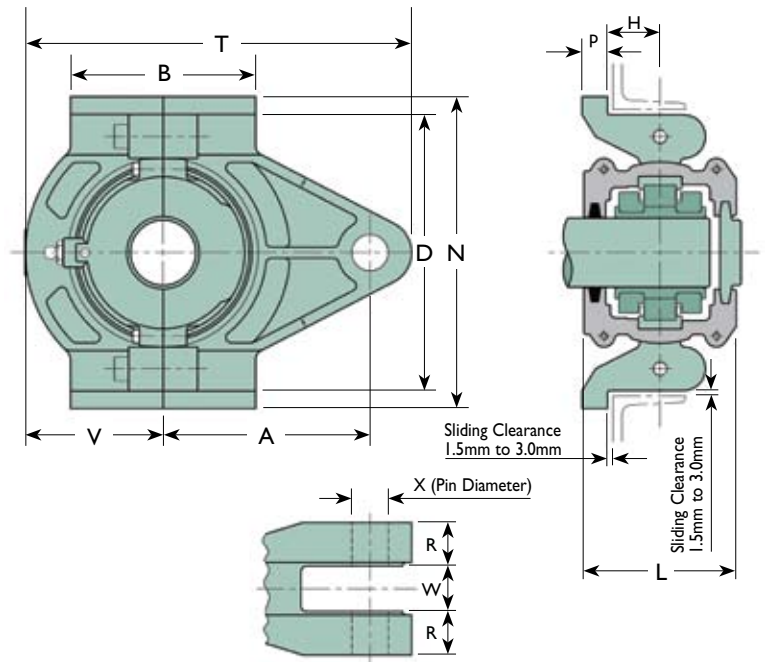

Shaft Diameter d (mm)	References		B (mm)	N (mm)	D (mm)	A (mm)	T (mm)	X (mm)	V (mm)	P (mm)	H (mm)	W (mm)	R (mm)	L (mm)	Mass (Complete unit) (kg)
	Complete unit (1)	Take-up housing only													
100	100 BCTT 100M	TT05	190	318	280	190	368	30	140	22	40	38	35	136	29
	01E BCTT 100M	TT06	204	342	305	210	414	36	152	22	43	44	35	134	34
	02 BCTT 100M	TT07	216	382	343	228	445	42	162	22	48	44	41	146	51
105	01E BCTT 105M	TT06	204	342	305	210	414	36	152	22	43	44	35	134	34
	02 BCTT 105M	TT07	216	382	343	228	445	42	162	22	48	44	41	146	51
110	100 BCTT 110M	TT06	204	342	305	210	414	36	152	22	43	44	35	134	33
	01 BCTT 110M	TT07	216	382	343	228	445	42	162	22	48	44	41	142	51
	02 BCTT 110M	TT08	254	420	381	260	508	42	190	25	51	44	44	162	71
115	01 BCTT 115M	TT07	216	382	343	228	445	42	162	22	48	44	41	142	51
	02 BCTT 115M	TT08	254	420	381	260	508	42	190	25	51	44	44	162	71
120	100 BCTT 120M	TT07	216	382	343	228	445	42	162	22	48	44	41	142	47
	01 BCTT 120M	TT08	254	420	381	260	508	42	190	25	51	44	44	156	71
	02 BCTT 120M	TT10	266	464	426	280	546	48	204	25	57	50	51	184	100
125	01 BCTT 125M	TT08	254	420	381	260	508	42	190	25	51	44	44	156	71
	02 BCTT 125M	TT10	266	464	426	280	546	48	204	25	57	50	51	184	100

(1) For bearing only reference (for standard arrangement) remove 'CTT' from complete unit reference and add 'GR', e.g. 01 B 110M GR

For cartridge reference refer to pages 32 and 36

METRIC TAKE-UP TENSION TYPE UNITS OVER 90mm BORE SIZE

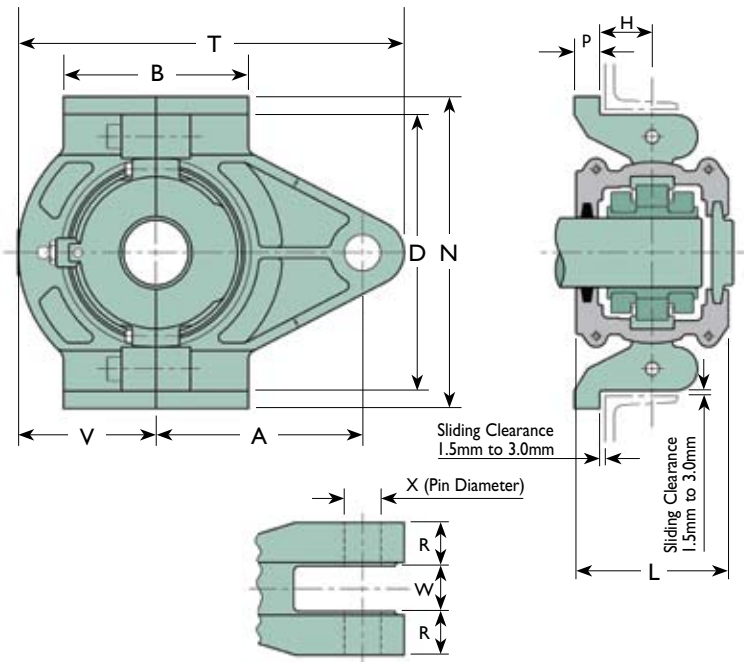

Shaft Diameter d (mm)	References		B (mm)	N (mm)	D (mm)	A (mm)	T (mm)	X (mm)	V (mm)	P (mm)	H (mm)	W (mm)	R (mm)	L (mm)	Mass (Complete unit) (kg)
	Complete unit (I)	Take-up housing only													
130	100 BCTT 130M	TT07	216	382	343	228	445	42	162	22	48	44	41	142	47
	01 BCTT 130M	TT08	254	420	381	260	508	42	190	25	51	44	44	156	71
	02 BCTT 130M	TT10	266	464	426	280	546	48	204	25	57	50	51	184	100
135	01 BCTT 135M	TT09	266	438	400	266	514	42	196	25	54	44	48	168	89
	02 BCTT 135M	TT30	280	502	464	298	584	48	222	25	60	50	54	188	119
140	100 BCTT 140M	TT08	254	420	381	260	508	42	190	25	51	44	44	156	67
	01 BCTT 140M	TT09	266	438	400	266	514	42	196	25	54	44	48	168	89
	02 BCTT 140M	TT30	280	502	464	298	584	48	222	25	60	50	54	188	119
150	100 BCTT 150M	TT09	266	438	400	266	514	42	196	25	54	44	48	168	82
	01 BCTT 150M	TT10	266	464	426	280	546	48	204	25	57	50	51	174	100
	02 BCTT 150M	TT31	305	528	489	312	616	48	235	25	64	50	57	204	141
155	01 BCTT 155M	TT10	266	464	426	280	546	48	204	25	57	50	51	174	100
	02 BCTT 155M	TT31	305	528	489	312	616	48	235	25	64	50	57	204	141

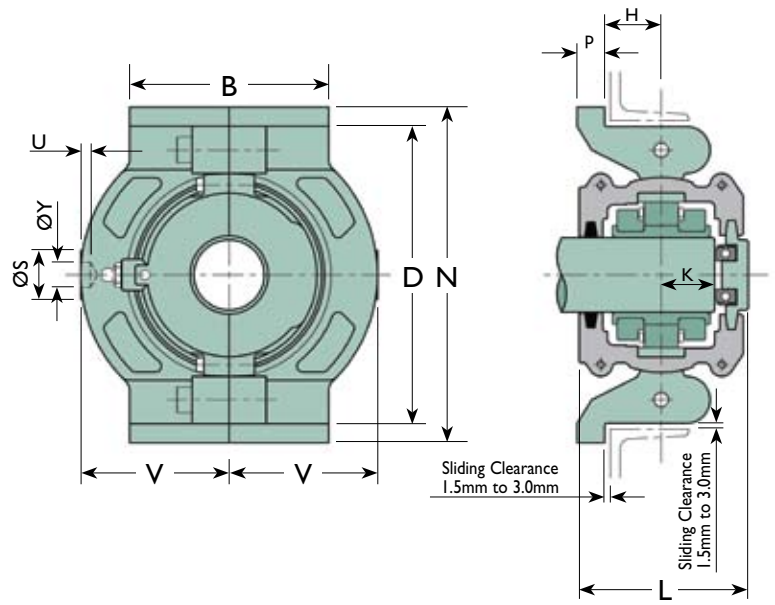

Shaft Diameter d (in)	References		B (mm)	N (mm)	D (mm)	V (mm)	K (mm)	P (mm)	H (mm)	L (mm)	S (mm)	Y (mm)	U (mm)	Mass (Complete unit) (kg)
	Complete unit (1)	Take-up housing only												
1 ³ / ₁₆	01 BCTP 103	TP01	102	172	153	76	27	14	29	86	25	13	5	6
1 ¹ / ₄	01 BCTP 104	TP01	102	172	153	76	27	14	29	86	25	13	5	6
1 ⁷ / ₁₆	01 BCTP 107	TP01	102	172	153	76	27	14	29	86	25	13	5	6
1 ¹ / ₂	01 BCTP 108	TP01	102	172	153	76	27	14	29	86	25	13	5	6
1 ¹¹ / ₁₆	01E BCTP 111	TP02	114	204	178	88	29	16	29	98	29	13	5	9
1 ³ / ₄	01E BCTP 112	TP02	114	204	178	88	29	16	29	98	29	13	5	9
1 ⁵ / ₁₆	01E BCTP 115	TP02	114	204	178	88	29	16	29	98	29	13	5	9
	02 BCTP 115	TP03	128	235	203	102	35	20	32	114	38	16	6	12
2	01E BCTP 200	TP02	114	204	178	88	29	16	29	98	29	13	5	9
	02 BCTP 200	TP03	128	235	203	102	35	20	32	114	38	16	6	12
2 ³ / ₁₆	01E BCTP 203	TP03	128	235	203	102	30	20	32	104	38	16	6	13
	02 BCTP 203	TP04	152	266	229	114	38	22	40	126	41	16	6	17

(1) For radial bearing only reference (for standard arrangement) remove 'CTP' from complete unit reference and add 'EX', e.g. 01E B 207 EX

Ball thrust bearings are usually supplied complete with blanking plate. Refer to page 22

For cartridge reference refer to pages 50 to 52

INCH-SIZE TAKE-UP PUSH TYPE UNITS TO 2¹⁵/₁₆" BORE SIZE

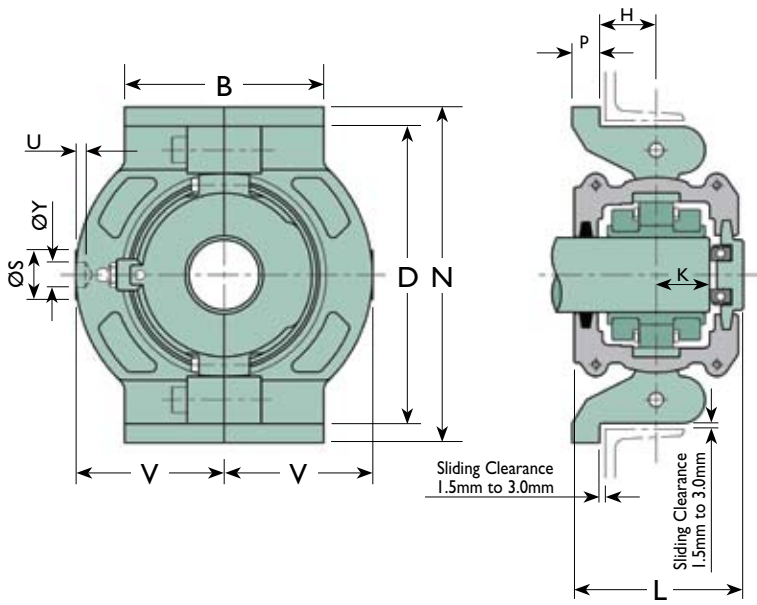

Shaft Diameter d (in)	References		B (mm)	N (mm)	D (mm)	V (mm)	K (mm)	P (mm)	H (mm)	L (mm)	S (mm)	Y (mm)	U (mm)	Mass (Complete unit) (kg)
	Complete unit (I)	Take-up housing only												
2 ¹ / ₄	01E BCTP 204	TP03	128	235	203	102	30	20	32	104	38	16	6	13
	02 BCTP 204	TP04	152	266	229	114	38	22	40	126	41	16	6	17
2 ⁷ / ₁₆	01E BCTP 207	TP03	128	235	203	102	30	20	32	104	38	16	6	13
	02 BCTP 207	TP04	152	266	229	114	38	22	40	126	41	16	6	17
2 ¹ / ₂	01E BCTP 208	TP03	128	235	203	102	30	20	32	104	38	16	6	13
	02 BCTP 208	TP04	152	266	229	114	38	22	40	126	41	16	6	17
2 ³ / ₄	01E BCTP 212	TP04	152	266	229	114	35	22	40	114	41	16	6	17
	02 BCTP 212	TP05	190	318	280	140	41	22	40	140	51	16	6	27
2 ¹⁵ / ₁₆	100 BCTP 215	TP03	128	235	203	102	30	20	32	104	38	16	6	13
	01E BCTP 215	TP04	152	266	229	114	35	22	40	114	41	16	6	17
	02 BCTP 215	TP05	190	318	280	140	41	22	40	140	51	16	6	27

INCH-SIZE TAKE-UP PUSH TYPE UNITS FROM 3" TO 3½" BORE SIZE

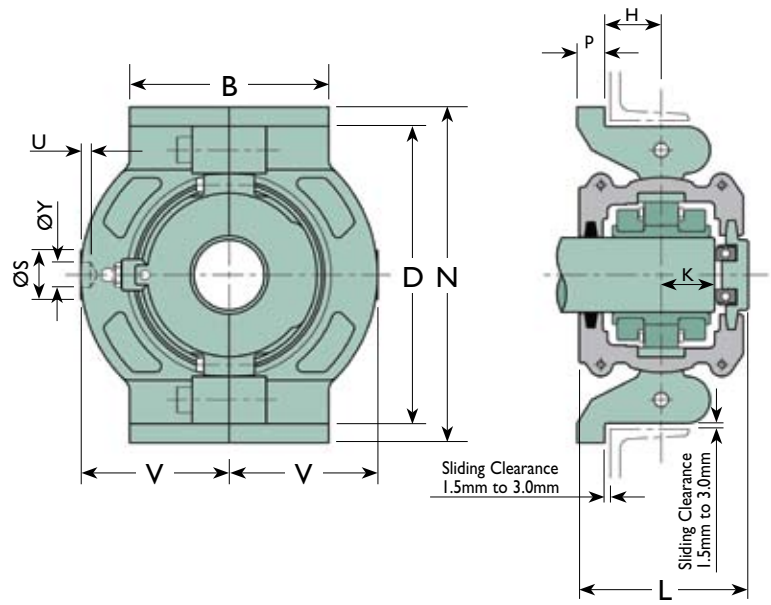

Shaft Diameter d (in)	References		B (mm)	N (mm)	D (mm)	V (mm)	K (mm)	P (mm)	H (mm)	L (mm)	S (mm)	Y (mm)	U (mm)	Mass (Complete unit) (kg)
	Complete unit (I)	Take-up housing only												
3	100 BCTP 300	TP03	128	235	203	102	30	20	32	104	38	16	6	13
	01E BCTP 300	TP04	152	266	229	114	35	22	40	114	41	16	6	17
	02 BCTP 300	TP05	190	318	280	140	41	22	40	140	51	16	6	27
3⅜	01E BCTP 303	TP05	190	318	280	140	40	22	40	136	51	16	6	27
	02 BCTP 303	TP06	204	342	305	152	48	22	43	154	51	19	6	31
3¼	01E BCTP 304	TP05	190	318	280	140	40	22	40	136	51	16	6	27
	02 BCTP 304	TP06	204	342	305	152	48	22	43	154	51	19	6	31
3⅞	100 BCTP 307	TP04	152	266	229	114	35	22	40	114	41	16	6	17
	01E BCTP 307	TP05	190	318	280	140	40	22	40	136	51	16	6	27
	02 BCTP 307	TP06	204	342	305	152	48	22	43	154	51	19	6	31
3½	01E BCTP 308	TP05	190	318	280	140	40	22	40	136	51	16	6	27
	02 BCTP 308	TP06	204	342	305	152	48	22	43	154	51	19	6	31

(I) For radial bearing only reference (for standard arrangement) remove 'CTP' from complete unit reference and add 'EX', e.g. 01E B 307 EX

Ball thrust bearings are usually supplied complete with blanking plate. Refer to page 22

For cartridge reference refer to pages 52 and 54

INCH-SIZE TAKE-UP PUSH TYPE UNITS FROM 3¹/₁₆" TO 4³/₁₆" BORE SIZE

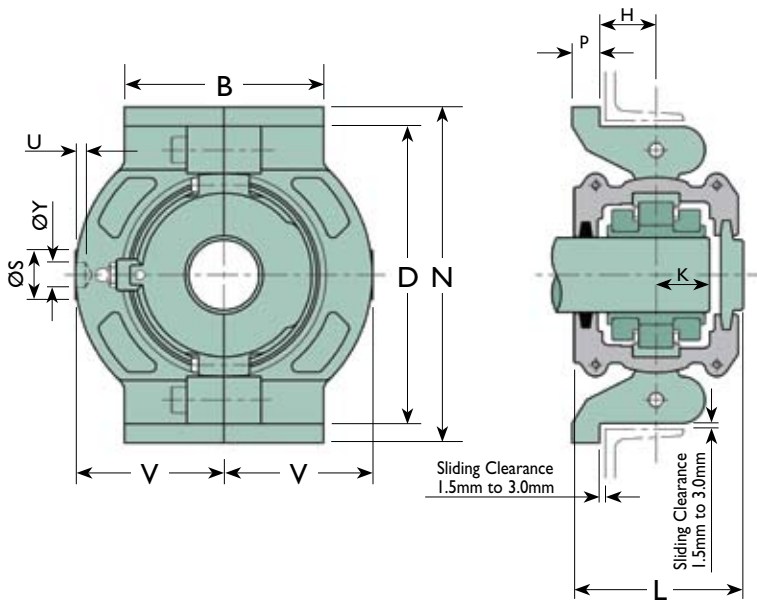

Shaft Diameter d (in)	References		B (mm)	N (mm)	D (mm)	V (mm)	P (mm)	H (mm)	L (mm)	S (mm)	Y (mm)	U (mm)	Mass (Complete unit) (kg)
	Complete unit (I)	Take-up housing only											
3 ¹ / ₁₆	01E BCTP 311	TP06	204	342	305	152	22	43	134	51	19	6	31
	02 BCTP 311	TP07	216	382	343	162	22	48	146	70	19	6	46
3 ³ / ₄	01E BCTP 312	TP06	204	342	305	152	22	43	134	51	19	6	31
	02 BCTP 312	TP07	216	382	343	162	22	48	146	70	19	6	46
3 ¹⁵ / ₁₆	100 BCTP 315	TP05	190	318	280	140	22	40	136	51	16	6	26
	01E BCTP 315	TP06	204	342	305	152	22	43	134	51	19	6	31
	02 BCTP 315	TP07	216	382	343	162	22	48	146	70	19	6	46
4	100 BCTP 400	TP05	190	318	280	140	22	40	136	51	16	6	26
	01E BCTP 400	TP06	204	342	305	152	22	43	134	51	19	6	31
	02 BCTP 400	TP07	216	382	343	162	22	48	146	70	19	6	46
4 ³ / ₁₆	01 BCTP 403	TP07	216	382	343	162	22	48	142	70	19	6	46
	02 BCTP 403	TP08	254	420	381	190	25	51	162	76	19	6	65

(I) For bearing only reference (for standard arrangement) remove 'CTP' from complete unit reference and add 'GR', e.g. 01 B 400 GR

For cartridge reference refer to pages 54 and 56

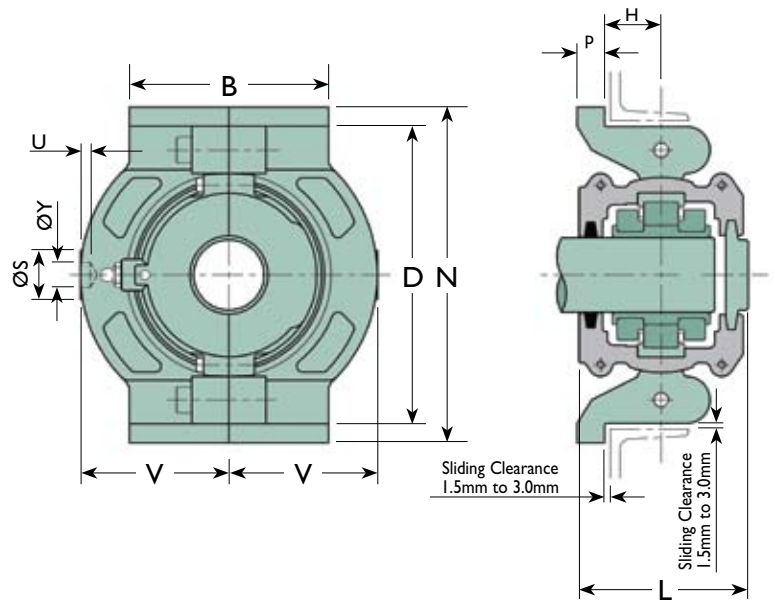

Shaft Diameter d (in)	References		B (mm)	N (mm)	D (mm)	V (mm)	P (mm)	H (mm)	L (mm)	S (mm)	Y (mm)	U (mm)	Mass (Complete unit) (kg)
	Complete unit (I)	Take-up housing only											
4 ⁷ / ₁₆	100 BCTP 407	TP06	204	342	305	152	22	43	134	51	19	6	29
	01 BCTP 407	TP07	216	382	343	162	22	48	142	70	19	6	46
	02 BCTP 407	TP08	254	420	381	190	25	51	162	76	19	6	65
4 ¹ / ₂	100 BCTP 408	TP06	204	342	305	152	22	43	134	51	19	6	29
	01 BCTP 408	TP07	216	382	343	162	22	48	142	70	19	6	46
	02 BCTP 408	TP08	254	420	381	190	25	51	162	76	19	6	65
4 ⁵ / ₁₆	100 BCTP 415	TP07	216	382	343	162	22	48	142	70	19	6	42
	01 BCTP 415	TP08	254	420	381	190	25	51	156	76	19	6	65
	02 BCTP 415	TP10	266	464	426	204	25	57	184	86	23	8	91
5	100 BCTP 500	TP07	216	382	343	162	22	48	142	70	19	6	42
	01 BCTP 500	TP08	254	420	381	190	25	51	156	76	19	6	65
	02 BCTP 500	TP10	266	464	426	204	25	57	184	86	23	8	91
5 ³ / ₁₆	01 BCTP 503	TP09	266	438	400	196	25	54	168	76	23	8	80
	02 BCTP 503	TP30	280	502	464	222	25	60	188	92	23	8	109

(I) For bearing only reference (for standard arrangement) remove 'CTP' from complete unit reference and add 'GR', e.g. 01 B 407 GR
 For cartridge reference refer to pages 56 and 58

INCH-SIZE TAKE-UP PUSH TYPE UNITS OVER 4³/₁₆" BORE SIZE

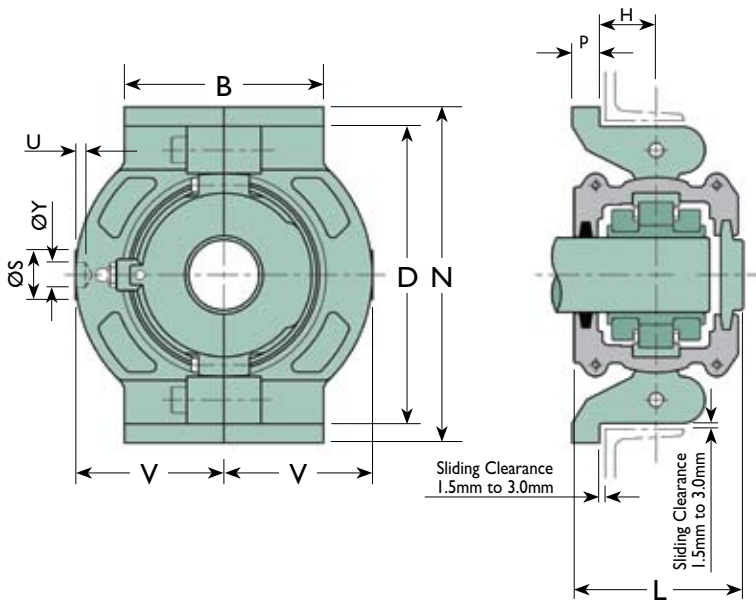

Shaft Diameter d (in)	References		B (mm)	N (mm)	D (mm)	V (mm)	P (mm)	H (mm)	L (mm)	S (mm)	Y (mm)	U (mm)	Mass (Complete unit) (kg)
	Complete unit (I)	Take-up housing only											
5 ⁷ / ₁₆	100 BCTP 507	TP08	254	420	381	190	25	51	156	76	19	6	60
	01 BCTP 507	TP09	266	438	400	196	25	54	168	76	23	8	80
	02 BCTP 507	TP30	280	502	464	222	25	60	188	92	23	8	109
5 ¹ / ₂	100 BCTP 508	TP08	254	420	381	190	25	51	156	76	19	6	60
	01 BCTP 508	TP09	266	438	400	196	25	54	168	76	23	8	80
	02 BCTP 508	TP30	280	502	464	222	25	60	188	92	23	8	109
5 ⁹ / ₁₆	100 BCTP 515	TP09	266	438	400	196	25	54	168	76	23	8	73
	01 BCTP 515	TP10	266	464	426	204	25	57	174	86	23	8	91
	02 BCTP 515	TP31	305	528	489	235	25	64	204	92	26	10	109
6	100 BCTP 600	TP09	266	438	400	196	25	54	168	76	23	8	73
	01 BCTP 600	TP10	266	464	426	204	25	57	174	86	23	8	91
	02 BCTP 600	TP31	305	528	489	235	25	64	204	92	26	10	109

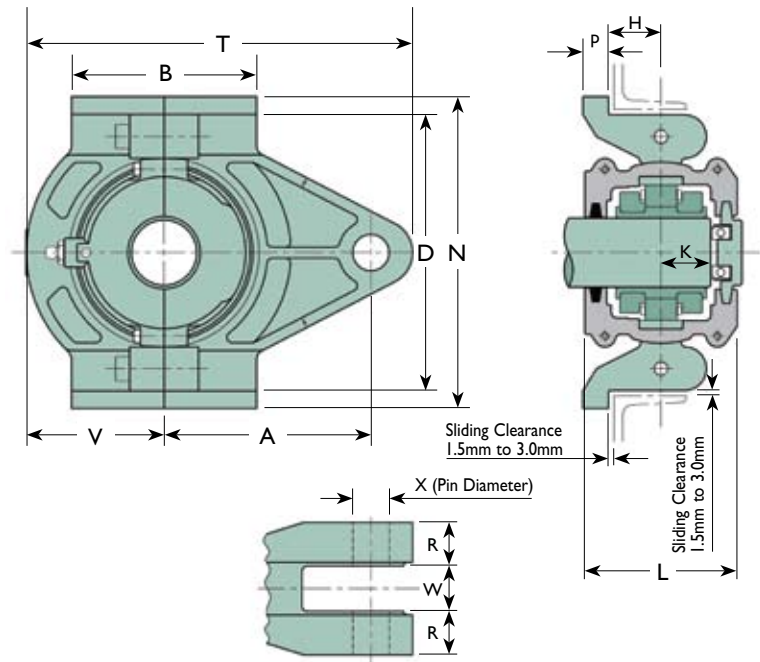

Shaft Diameter d (in)	References		B (mm)	N (mm)	D (mm)	A (mm)	T (mm)	X (mm)	V (mm)	K (mm)	P (mm)	H (mm)	W (mm)	R (mm)	L (mm)	Mass (Complete unit) (kg)
	Complete unit (1)	Take-up housing only														
1 3/16	01 BCTT 103	TT01	102	172	153	114	216	20	76	27	14	29	25	24	86	7
1 1/4	01 BCTT 104	TT01	102	172	153	114	216	20	76	27	14	29	25	24	86	7
1 7/16	01 BCTT 107	TT01	102	172	153	114	216	20	76	27	14	29	25	24	86	7
1 1/2	01 BCTT 108	TT01	102	172	153	114	216	20	76	27	14	29	25	24	86	7
1 11/16	01E BCTT 111	TT02	114	204	178	128	242	24	88	29	16	29	25	25	98	10
1 3/4	01E BCTT 112	TT02	114	204	178	128	242	24	88	29	16	29	25	25	98	10
1 5/8	01E BCTT 115	TT02	114	204	178	128	242	24	88	29	16	29	25	25	98	10
	02 BCTT 115	TT03	128	235	203	146	280	24	102	35	20	32	30	29	114	13
2	01E BCTT 200	TT02	114	204	178	128	242	24	88	29	16	29	25	25	98	10
	02 BCTT 200	TT03	128	235	203	146	280	24	102	35	20	32	30	29	114	13
2 3/16	01E BCTT 203	TT03	128	235	203	146	280	24	102	30	20	32	30	29	104	13
	02 BCTT 203	TT04	152	266	229	158	305	24	114	38	22	40	30	32	126	19

- (1) For radial bearing only reference (for standard arrangement) remove 'CTT' from complete unit reference and add 'EX', e.g. 01E B 207 EX
- Ball thrust bearings are usually supplied complete with blanking plate. Refer to page 22
- For cartridge reference refer to pages 50 and 52

INCH-SIZE TAKE-UP TENSION TYPE UNITS TO 2¹⁵/₁₆" BORE SIZE

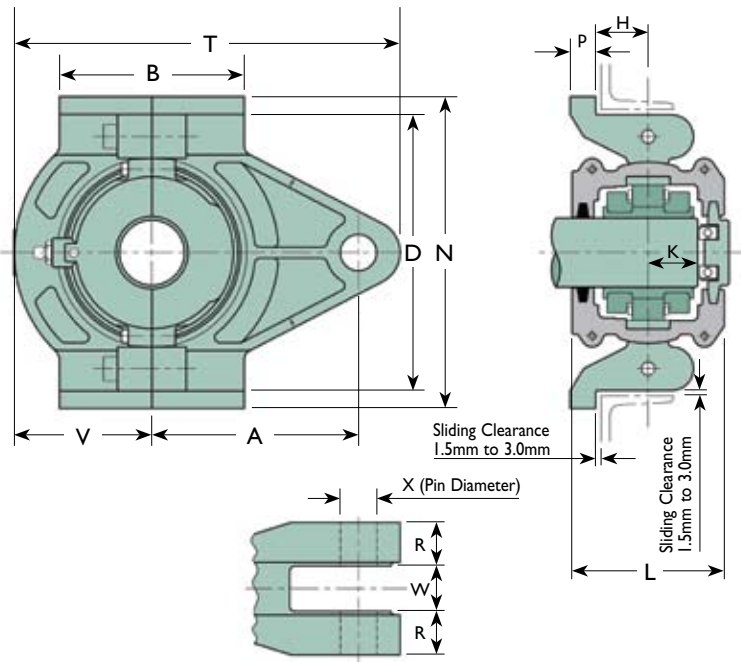

Shaft Diameter d (in)	References		B (mm)	N (mm)	D (mm)	A (mm)	T (mm)	X (mm)	V (mm)	K (mm)	P (mm)	H (mm)	W (mm)	R (mm)	L (mm)	Mass (Complete unit) (kg)
	Complete unit (1)	Take-up housing only														
2 ¹ / ₄	01E BCTT 204	TT03	128	235	203	146	280	24	102	30	20	32	30	29	104	13
	02 BCTT 204	TT04	152	266	229	158	305	24	114	38	22	40	30	32	126	19
2 ⁷ / ₁₆	01E BCTT 207	TT03	128	235	203	146	280	24	102	30	20	32	30	29	104	13
	02 BCTT 207	TT04	152	266	229	158	305	24	114	38	22	40	30	32	126	19
2 ¹ / ₂	01E BCTT 208	TT03	128	235	203	146	280	24	102	30	20	32	30	29	104	13
	02 BCTT 208	TT04	152	266	229	158	305	24	114	38	22	40	30	32	126	19
2 ¹¹ / ₁₆	01E BCTT 211	TT04	152	266	229	158	305	24	114	35	22	40	30	32	114	19
	02 BCTT 211	TT05	190	318	280	190	368	30	140	41	22	40	38	35	140	30
2 ³ / ₄	01E BCTT 212	TT04	152	266	229	158	305	24	114	35	22	40	30	32	114	19
	02 BCTT 212	TT05	190	318	280	190	368	30	140	41	22	40	38	35	140	30
2 ¹⁵ / ₁₆	100 BCTT 215	TT03	128	235	203	146	280	24	102	30	20	32	30	29	104	13
	01E BCTT 215	TT04	152	266	229	158	305	24	114	35	22	40	30	32	114	19
	02 BCTT 215	TT05	190	318	280	190	368	30	140	41	22	40	38	35	140	30

INCH-SIZE TAKE-UP TENSION TYPE UNITS FROM 3" TO 3½" BORE SIZE

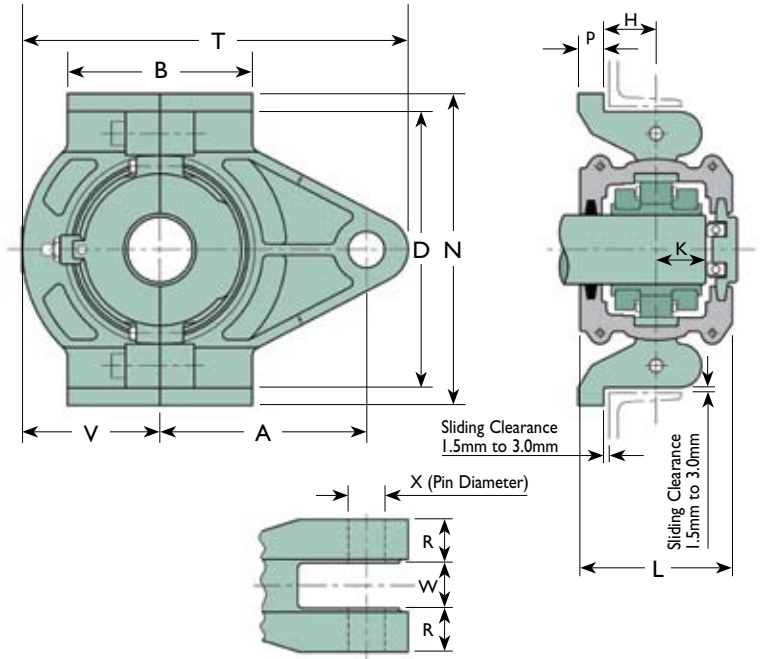

Shaft Diameter d (in)	References		B (mm)	N (mm)	D (mm)	A (mm)	T (mm)	X (mm)	V (mm)	K (mm)	P (mm)	H (mm)	W (mm)	R (mm)	L (mm)	Mass (Complete unit) (kg)
	Complete unit (1)	Take-up housing only														
3	100 BCTT 300	TT03	128	235	203	146	280	24	102	30	20	32	30	29	104	13
	01E BCTT 300	TT04	152	266	229	158	305	24	114	35	22	40	30	32	114	19
	02 BCTT 300	TT05	190	318	280	190	368	30	140	41	22	40	38	35	140	30
3¾	01E BCTT 303	TT05	190	318	280	190	368	30	140	40	22	40	38	35	136	30
	02 BCTT 303	TT06	204	342	305	210	414	36	152	48	22	43	44	35	154	34
3¼	01E BCTT 304	TT05	190	318	280	190	368	30	140	40	22	40	38	35	136	30
	02 BCTT 304	TT06	204	342	305	210	414	36	152	48	22	43	44	35	154	34
3⅞	100 BCTT 307	TT04	152	266	229	158	305	24	114	35	22	40	30	32	114	19
	01E BCTT 307	TT05	190	318	280	190	368	30	140	40	22	40	38	35	136	30
	02 BCTT 307	TT06	204	342	305	210	414	36	152	48	22	43	44	35	154	34
3½	01E BCTT 308	TT05	190	318	280	190	368	30	140	40	22	40	38	35	136	30
	02 BCTT 308	TT06	204	342	305	210	414	36	152	48	22	43	44	35	154	34

(1) For radial bearing only reference (for standard arrangement) remove 'CTT' from complete unit reference and add 'EX', e.g. 01E B 307 EX

Ball thrust bearings are usually supplied complete with blanking plate. Refer to page 22

For cartridge reference refer to pages 52 and 54

INCH-SIZE TAKE-UP TENSION TYPE UNITS FROM 3¹/₁₆" TO 4³/₁₆" BORE SIZE

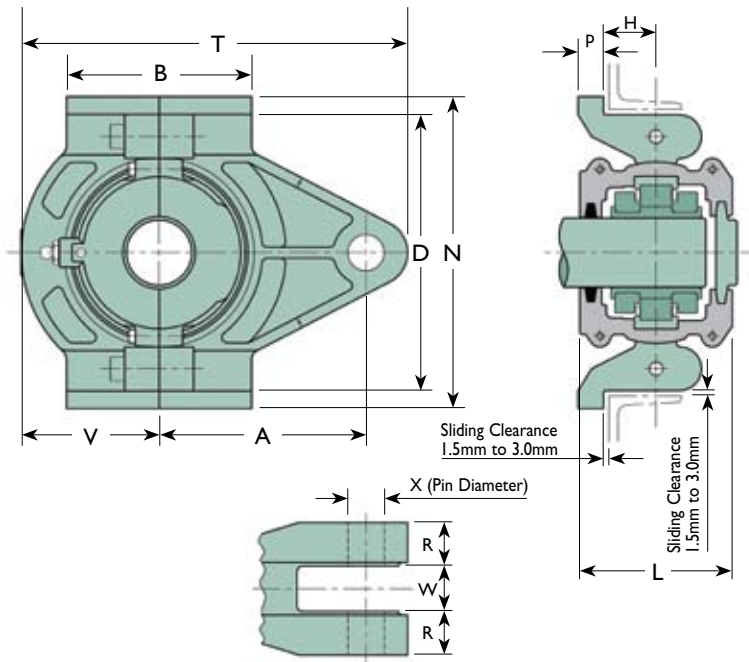

Shaft Diameter d (in)	References		B (mm)	N (mm)	D (mm)	A (mm)	T (mm)	X (mm)	V (mm)	P (mm)	H (mm)	W (mm)	R (mm)	L (mm)	Mass (Complete unit) (kg)
	Complete unit (I)	Take-up housing only													
3 ¹ / ₁₆	01E BCTT 311	TT06	204	342	305	210	414	36	152	22	43	44	35	134	34
	02 BCTT 311	TT07	216	382	343	228	445	42	162	22	48	44	41	146	51
3 ³ / ₁₆	01E BCTT 312	TT06	204	342	305	210	414	36	152	22	43	44	35	134	34
	02 BCTT 312	TT07	216	382	343	228	445	42	162	22	48	44	41	146	51
3 ¹⁵ / ₁₆	100 BCTT 315	TT05	190	318	280	190	368	30	140	22	40	38	35	136	29
	01E BCTT 315	TT06	204	342	305	210	414	36	152	22	43	44	35	134	34
	02 BCTT 315	TT07	216	382	343	228	445	42	162	22	48	44	41	146	51
4	100 BCTT 400	TT05	190	318	280	190	368	30	140	22	40	38	35	136	29
	01E BCTT 400	TT06	204	342	305	210	414	36	152	22	43	44	35	134	34
	02 BCTT 400	TT07	216	382	343	228	445	42	162	22	48	44	41	146	51
4 ³ / ₁₆	01 BCTT 403	TT07	216	382	343	228	445	42	162	22	48	44	41	142	51
	02 BCTT 403	TT08	254	420	381	260	508	42	190	25	51	44	44	162	71

(I) For bearing only reference (for standard arrangement) remove 'CTT' from complete unit reference and add 'GR', e.g. 01 B 407 GR

For cartridge reference refer to pages 54 and 56

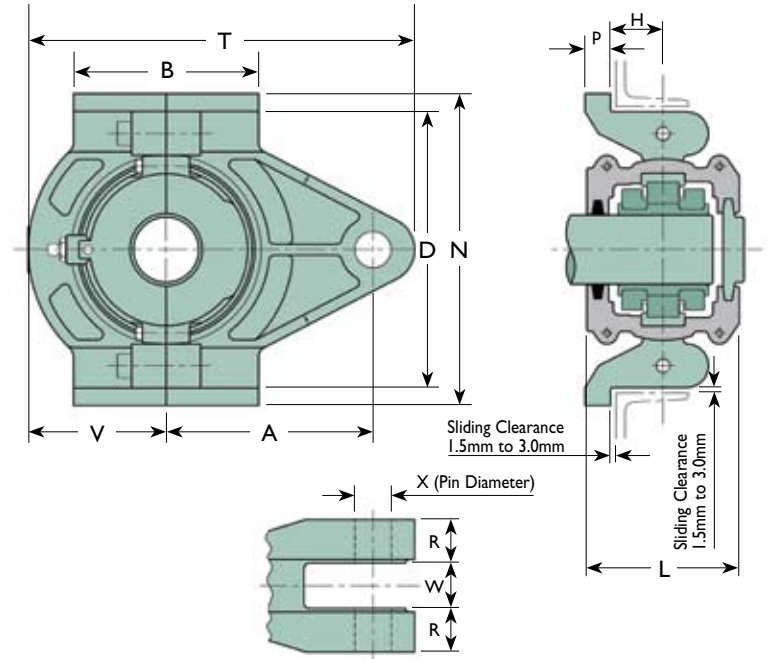

Shaft Diameter d (in)	References		B (mm)	N (mm)	D (mm)	A (mm)	T (mm)	X (mm)	V (mm)	P (mm)	H (mm)	W (mm)	R (mm)	L (mm)	Mass (Complete unit) (kg)
	Complete unit (1)	Take-up housing only													
4 ⁷ / ₁₆	100 BCTT 407	TT06	204	342	305	210	414	36	152	22	43	44	35	134	33
	01 BCTT 407	TT07	216	382	343	228	445	42	162	22	48	44	41	142	51
	02 BCTT 407	TT08	254	420	381	260	508	42	190	25	51	44	44	162	71
4 ¹ / ₂	100 BCTT 408	TT06	204	342	305	210	414	36	152	22	43	44	35	134	33
	01 BCTT 408	TT07	216	382	343	228	445	42	162	22	48	44	41	142	51
	02 BCTT 408	TT08	254	420	381	260	508	42	190	25	51	44	44	162	71
4 ¹⁵ / ₁₆	100 BCTT 415	TT07	216	382	343	228	445	42	162	22	48	44	41	142	47
	01 BCTT 415	TT08	254	420	381	260	508	42	190	25	51	44	44	156	71
	02 BCTT 415	TT10	266	464	426	280	546	48	204	25	57	50	51	184	100
5	100 BCTT 500	TT07	216	382	343	228	445	42	162	22	48	44	41	142	47
	01 BCTT 500	TT08	254	420	381	260	508	42	190	25	51	44	44	156	71
	02 BCTT 500	TT10	266	464	426	280	546	48	204	25	57	50	51	184	100
5 ³ / ₁₆	01 BCTT 503	TT09	266	438	400	266	514	42	196	25	54	44	48	168	89
	02 BCTT 503	TT30	280	502	464	298	584	48	222	25	60	50	54	188	119

(1) For bearing only reference (for standard arrangement) remove 'CTT' from complete unit reference and add 'GR', e.g. 01 B 407 GR
 For cartridge reference refer to pages 56 and 58

INCH-SIZE TAKE-UP TENSION TYPE UNITS OVER 4³/₁₆" BORE SIZE

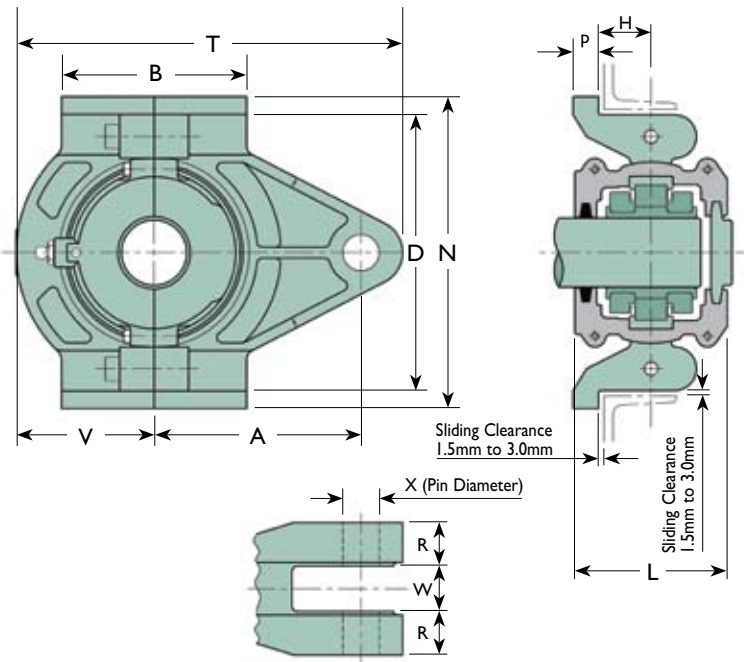

Shaft Diameter d (in)	References		B (mm)	N (mm)	D (mm)	A (mm)	T (mm)	X (mm)	V (mm)	P (mm)	H (mm)	W (mm)	R (mm)	L (mm)	Mass (Complete unit) (kg)
	Complete unit (I)	Take-up housing only													
5 ⁷ / ₁₆	100 BCTT 507	TT08	254	420	381	260	508	42	190	25	51	44	44	156	67
	01 BCTT 507	TT09	266	438	400	266	514	42	196	25	54	44	48	168	89
	02 BCTT 507	TT30	280	502	464	298	584	48	222	25	60	50	54	188	119
5 ¹ / ₂	100 BCTT 508	TT08	254	420	381	260	508	42	190	25	51	44	44	156	67
	01 BCTT 508	TT09	266	438	400	266	514	42	196	25	54	44	48	168	89
	02 BCTT 508	TT30	280	502	464	298	584	48	222	25	60	50	54	188	119
5 ¹⁵ / ₁₆	100 BCTT 515	TT09	266	438	400	266	514	42	196	25	54	44	48	168	82
	01 BCTT 515	TT10	266	464	426	280	546	48	204	25	57	50	51	174	100
	02 BCTT 515	TT31	305	528	489	312	616	48	235	25	64	50	57	204	141
6	100 BCTT 600	TT09	266	438	400	266	514	42	196	25	54	44	48	168	82
	01 BCTT 600	TT10	266	464	426	280	546	48	204	25	57	50	51	174	100
	02 BCTT 600	TT31	305	528	489	312	616	48	235	25	64	50	57	204	141

ROD END BEARING UNITS

Cooper split roller bearings in rod end housings provide a simple way of mounting roller bearings on cranks. As the complete bearing and housing unit is split radially, cranks can be made solid rather than being built-up or overhung. Typical applications include shaker screens and classifiers.

Rod ends are available to suit 100, 01/01E and 02 Series bearings as shown on pages 30 to 36 and 50 to 58.

Each rod end consists of a split outer casing, which encloses a fixed (GR) bearing in a swivel cartridge (refer to page 28). Two basic configurations are available – the 'T' type and the 'shoe' type. These can be modified to suit various rods and attachments.

Standard rod ends are of grey iron. Spheroidal graphite iron or steel versions are available.

Rod ends are supplied with matched cartridge to reduce the clearance between the cartridge and rod-end (S1 fit).

Except for very slow speed applications, bearings with C2 clearance should be specified.

Dimensions and load capacities of housings should be confirmed before finalising designs.

Shaft Dimensions

Journals should be machined to h6 tolerance. Close tolerance machining to the sides of the journal is not required. These are clearance only (i.e. not locating) as the bearing is positioned by the inner race being clamped onto the shaft.

The journal widths and fillet radii listed in the tables are suggested dimensions to clear standard Cooper cartridges. Special cartridges may be supplied if narrower journals are required.

'T' TYPE

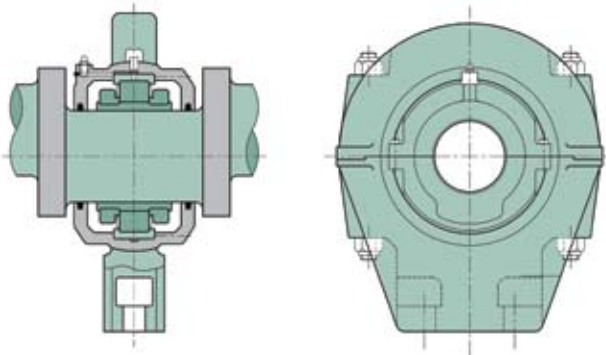

SHOE TYPE

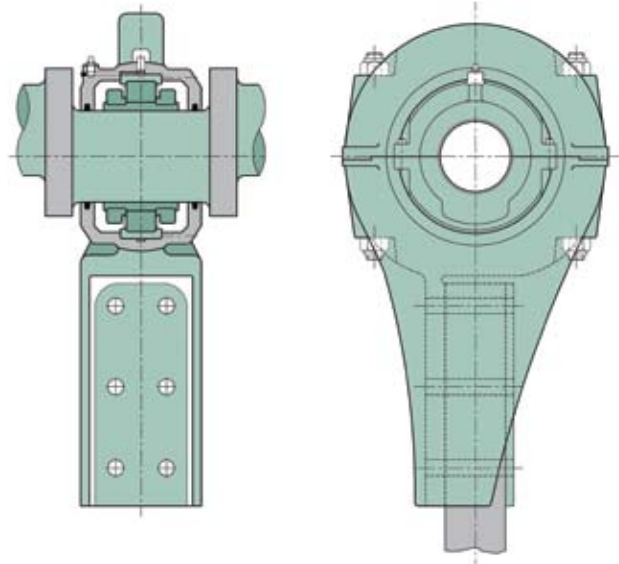

METRIC ROD-END BEARING UNITS T TYPE TO 80mm BORE SIZE

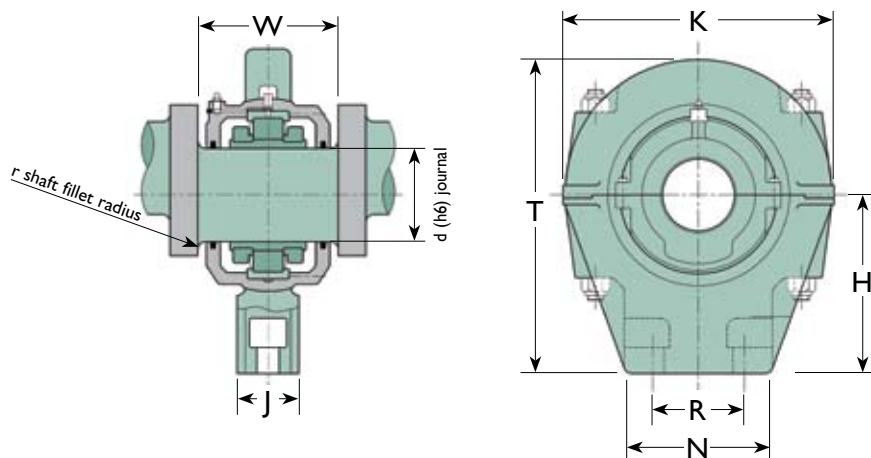

Shaft Diameter d (mm)	Reference (1) (Complete unit)	W (mm)	r (max) (mm)	N (mm)	J (mm)	H (mm)	K (mm)	T (mm)	R (mm)	Bolts	Mass (Complete unit) (kg)
40	01 BCRET 40M	92	3	86	30	76	140	152	57(2)	M12	6
45	01E BCRET 45M	104	3	102	32	102	166	190	70	M10	8
50	01E BCRET 50M	104	3	102	32	102	166	190	70	M10	8
	02 BCRET 50M	123	4.5	115	38	95	197	194	76(2)	M16	9
60	01E BCRET 60M	113	4.5	115	38	95	197	194	76(2)	M16	9
	02 BCRET 60M	138	6	128	44	108	216	220	89(2)	M16	13
65	01E BCRET 65M	113	4.5	115	38	95	197	194	76(2)	M16	9
	02 BCRET 65M	138	6	128	44	108	216	220	89(2)	M16	13
70	01E BCRET 70M	126	6	128	44	108	216	220	89(2)	M16	13
	02 BCRET 70M	152	6	146	48	127	248	256	102(2)	M20	20
75	100 BCRET 75M	113	4.5	115	38	95	197	194	76(2)	M16	9
	01E BCRET 75M	126	6	128	44	108	216	220	89(2)	M16	13
	02 BCRET 75M	152	6	146	48	127	248	256	102(2)	M20	20
80	01E BCRET 80M	148	6	146	48	127	248	256	102(2)	M20	20
	02 BCRET 80M	173	9.5	170	76	200	308	356	124	M24	36

(1) For (matched) rod-end and cartridge only without roller bearing remove 'B' from reference, e.g. 01E CRET 65M
For (standard rod-end specification) bearing only remove 'CRET' from reference and add 'GR C2', e.g. 01E B 65M GR C2

(2) Holes tapped in end face

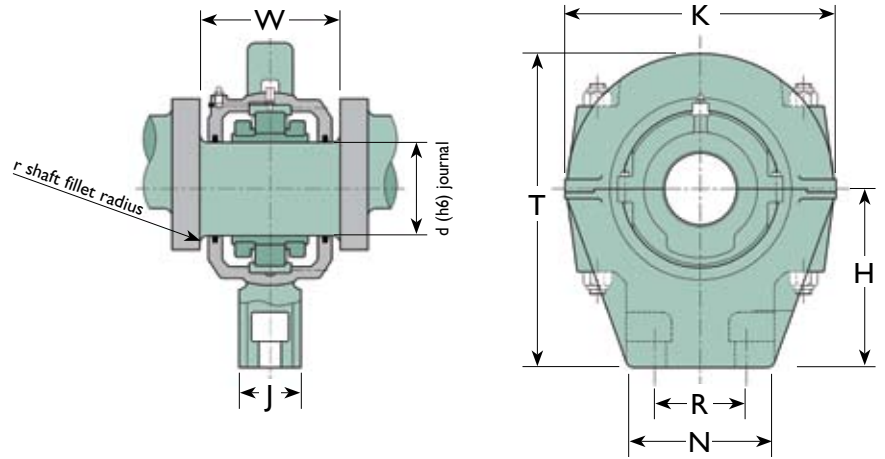

Shaft Diameter d (mm)	Reference (1) (Complete unit)	W (mm)	r (max) (mm)	N (mm)	J (mm)	H (mm)	K (mm)	T (mm)	R (mm)	Bolts	Mass (Complete unit) (kg)
85	100 BCRET 85M	126	6	128	44	108	216	220	89(2)	M16	13
	01E BCRET 85M	148	6	146	48	127	248	256	102(2)	M20	20
	02 BCRET 85M	173	9.5	170	76	200	308	356	124	M24	36
90	01E BCRET 90M	148	6	146	48	127	248	256	102(2)	M20	20
	02 BCRET 90M	173	9.5	170	76	200	308	356	124	M24	36
100	100 BCRET 100M	148	6	146	48	127	248	256	102(2)	M20	19
	01E BCRET 100M	146	6	170	76	200	308	356	124	M24	36
	02 BCRET 100M	171	12.5	190	86	222	334	390	136	M30	52
105	01E BCRET 105M	146	6	170	76	200	308	356	124	M24	36
	02 BCRET 105M	171	12.5	190	86	222	334	390	136	M30	52
110	100 BCRET 110M	146	6	170	76	200	308	356	124	M24	35
	01 BCRET 110M	154	6	190	86	222	334	390	136	M30	52
	02 BCRET 110M	187	12.5	190	86	222	375	425	136	M30	65
115	01 BCRET 115M	154	6	190	86	222	334	390	136	M30	52
	02 BCRET 115M	187	12.5	190	86	222	375	425	136	M30	65

- (1) For (matched) rod-end and cartridge only without roller bearing remove 'B' from reference, e.g. 01 CRET 110M
For (standard rod-end specification) bearing only remove 'CRET' from reference and add 'GR C2', e.g. 01 B 110M GR C2

- (2) Holes tapped in end face

METRIC ROD-END BEARING UNITS T TYPE FROM 85mm TO 155mm BORE SIZE

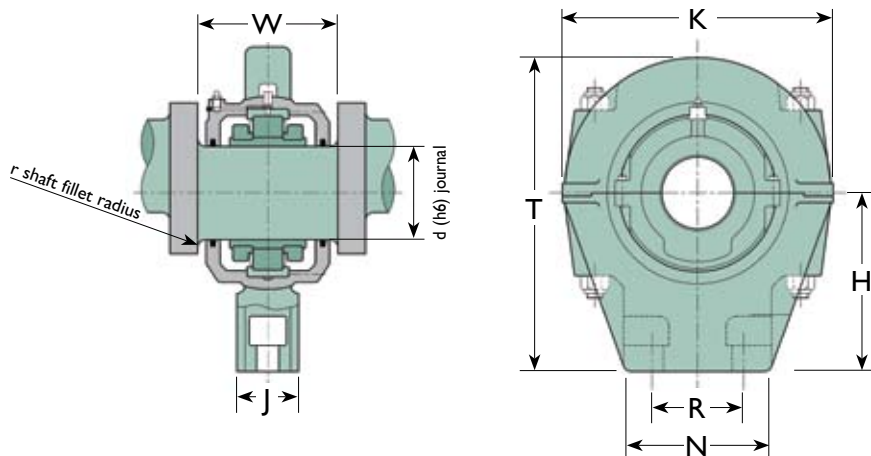

Shaft Diameter d (mm)	Reference (1) (Complete unit)	W (mm)	r (max) (mm)	N (mm)	J (mm)	H (mm)	K (mm)	T (mm)	R (mm)	Bolts	Mass (Complete unit) (kg)
120	100 BCRET 120M	154	6	190	86	222	334	390	136	M30	48
	01 BCRET 120M	168	6	190	86	222	375	425	136	M30	65
	02 BCRET 120M	209	12.5	204	102	279	442	502	140	M30	99
125	01 BCRET 125M	168	6	190	86	222	375	425	136	M30	65
	02 BCRET 125M	209	12.5	204	102	279	442	502	140	M30	99
130	100 BCRET 130M	154	6	190	86	222	334	390	136	M30	48
	01 BCRET 130M	168	6	190	86	222	375	425	136	M30	65
	02 BCRET 130M	209	12.5	204	102	279	442	502	140	M30	99
135	01 BCRET 135M	187	9.5	204	102	279	442	502	140	M30	89
140	100 BCRET 140M	168	6	190	86	222	375	425	136	M30	60
	01 BCRET 140M	187	9.5	204	102	279	442	502	140	M30	89
	02 BCRET 140M	213	12.5	204	102	279	445	558	140	M30	119
150	100 BCRET 150M	187	9.5	204	102	279	442	502	140	M30	82
	01 BCRET 150M	193	9.5	204	102	279	442	502	140	M30	99
	02 BCRET 150M	229	12.5	204	102	279	445	558	140	M30	131
155	01 BCRET 155M	193	9.5	204	102	279	442	502	140	M30	99
	02 BCRET 155M	229	12.5	204	102	279	445	558	140	M30	131

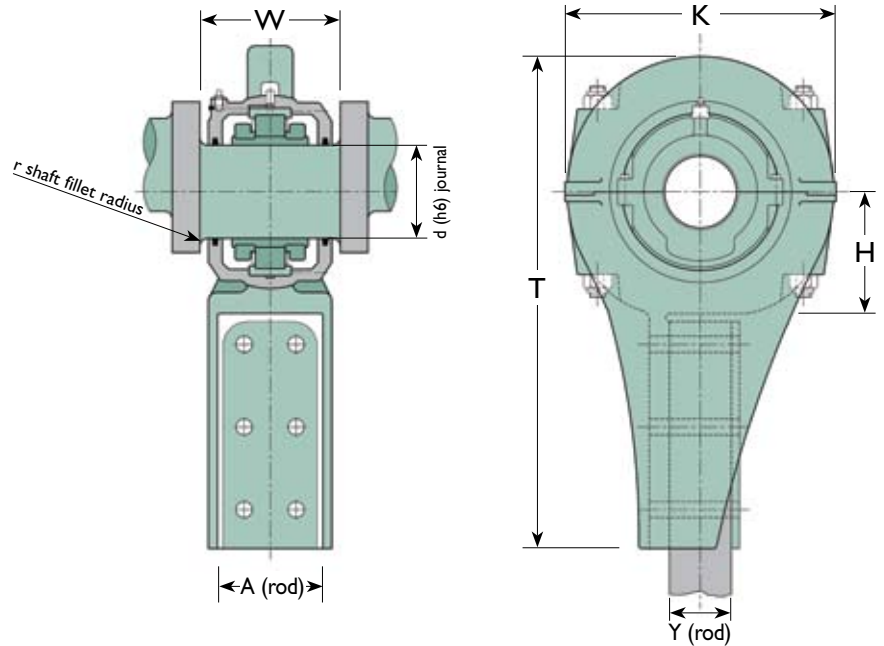

Shaft Diameter d (mm)	Reference (1) (Complete unit)	W (mm)	r (max) (mm)	A(2) (rod) (mm)	Y(2) (rod) (mm)	H (mm)	K (mm)	T (mm)	Mass (Complete unit) (kg)
40	01 BCRES 40M	92	3	62	10	65	160	258	5
45	01E BCRES 45M	104	3	62	10	70	166	308	7
50	01E BCRES 50M	104	3	62	10	70	166	308	7
	02 BCRES 50M	123	4.5	62	32	76	190	330	10
60	01E BCRES 60M	113	4.5	62	10	79	190	330	13
	02 BCRES 60M	138	6	88	50	108	248	432	20
65	01E BCRES 65M	113	4.5	62	10	79	190	330	13
	02 BCRES 65M	138	6	88	50	108	248	432	20
70	01E BCRES 70M	126	6	88	50	108	248	432	22
	02 BCRES 70M	152	6	114	38	130	248	540	40
75	100 BCRES 75M	113	4.5	62	10	79	190	330	13
	01E BCRES 75M	126	6	88	50	108	248	432	22
	02 BCRES 75M	152	6	114	38	130	248	540	40
80	01E BCRES 80M	148	6	100	50	133	264	602	43
	02 BCRES 80M	173	9.5	126	76	149	334	610	62

(1) For (matched) rod-end and cartridge only without roller bearing remove 'B' from reference, e.g. 01E CRES 75M
For (standard rod-end specification) bearing only remove 'CRES' from reference and add 'GR C2', e.g. 01E B 75M GR C2

(2) Rod fixing varies from 2 to 6 bolts according to size, and can be adapted to requirements

METRIC ROD-END BEARING UNITS SHOE TYPE TO 115mm BORE SIZE

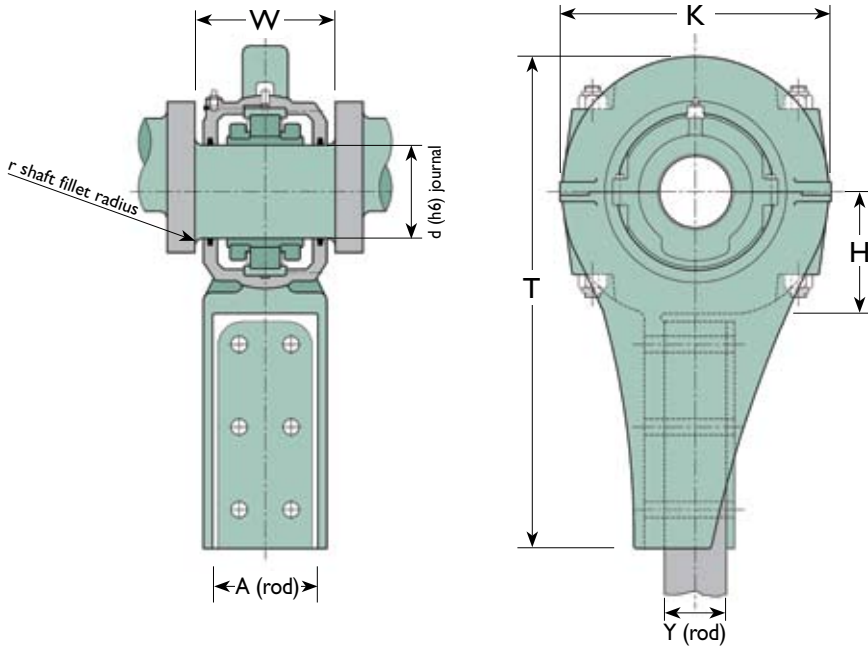

Shaft Diameter d (mm)	Reference (1) (Complete unit)	W (mm)	r (max) (mm)	A(2) (rod) (mm)	Y(2) (rod) (mm)	H (mm)	K (mm)	T (mm)	Mass (Complete unit) (kg)
85	100 BCRES 85M	126	6	88	50	108	248	432	23
	01E BCRES 85M	148	6	100	50	133	264	602	43
	02 BCRES 85M	173	9.5	126	76	149	334	610	62
90	01E BCRES 90M	148	6	100	50	133	264	602	43
	02 BCRES 90M	173	9.5	126	76	149	334	610	62
100	100 BCRES 100M	148	6	114	38	130	248	540	36
	01E BCRES 100M	146	6	100	58	125	308	572	44
	02 BCRES 100M	171	12.5	126	76	149	354	618	71
105	01E BCRES 105M	146	6	100	58	125	308	572	44
	02 BCRES 105M	171	12.5	126	76	149	354	618	71
110	100 BCRES 110M	146	6	100	58	125	308	572	43
	01 BCRES 110M	154	6	126	58	149	354	618	63
	02 BCRES 110M	187	12.5	126	76	162	400	654	91
115	01 BCRES 115M	154	6	126	58	149	354	618	63
	02 BCRES 115M	187	12.5	126	76	162	400	654	91

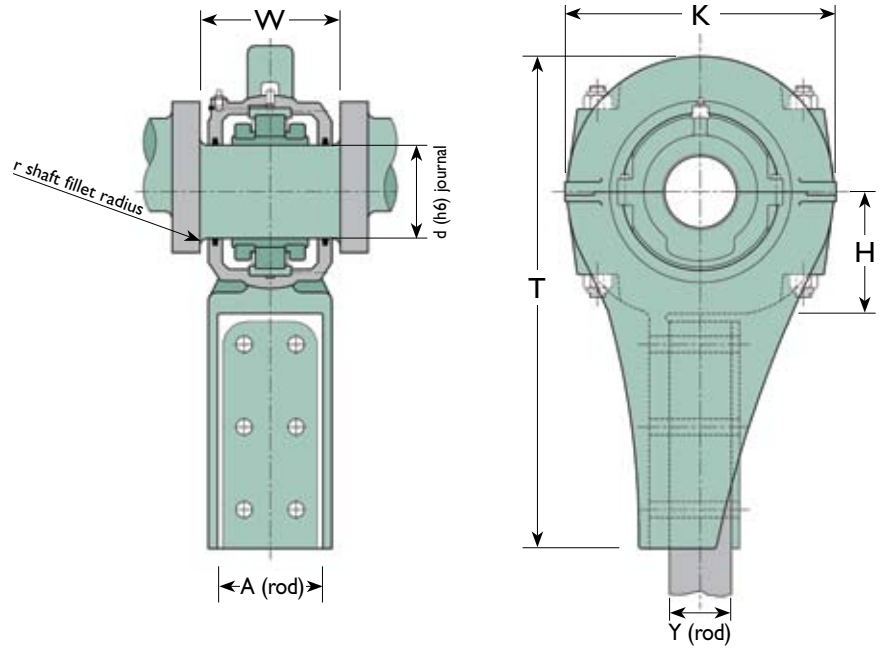

Reference (1) (Complete unit)	Shaft Diameter d (mm)	W (mm)	r (max) (mm)	A(2) (rod) (mm)	Y(2) (rod) (mm)	H (mm)	K (mm)	T (mm)	Mass (Complete unit) (kg)
100 BCRES 120M	120	154	6	126	58	149	354	618	59
01 BCRES 120M		168	6	126	64	158	400	654	83
02 BCRES 120M		209	12.5	152	76	177	442	696	124
01 BCRES 125M	125	168	6	126	64	158	400	654	83
02 BCRES 125M		209	12.5	152	76	177	442	696	124
100 BCRES 130M	130	154	6	126	58	149	354	610	59
01 BCRES 130M		168	6	126	64	158	400	654	83
02 BCRES 130M		209	12.5	152	76	177	442	696	124
01 BCRES 135M	135	187	9.5	152	76	177	442	696	98

(1) For (matched) rod-end and cartridge only without roller bearing remove 'B' from reference, e.g. 01 CRES 120M
For (standard rod-end specification) bearing only remove 'CRES' from reference and add 'GR C2', e.g. 01 B 120M GR C2

(2) Rod fixing varies from 2 to 6 bolts according to size, and can be adapted to requirements

METRIC ROD-END BEARING UNITS SHOE TYPE OVER 115mm BORE SIZE

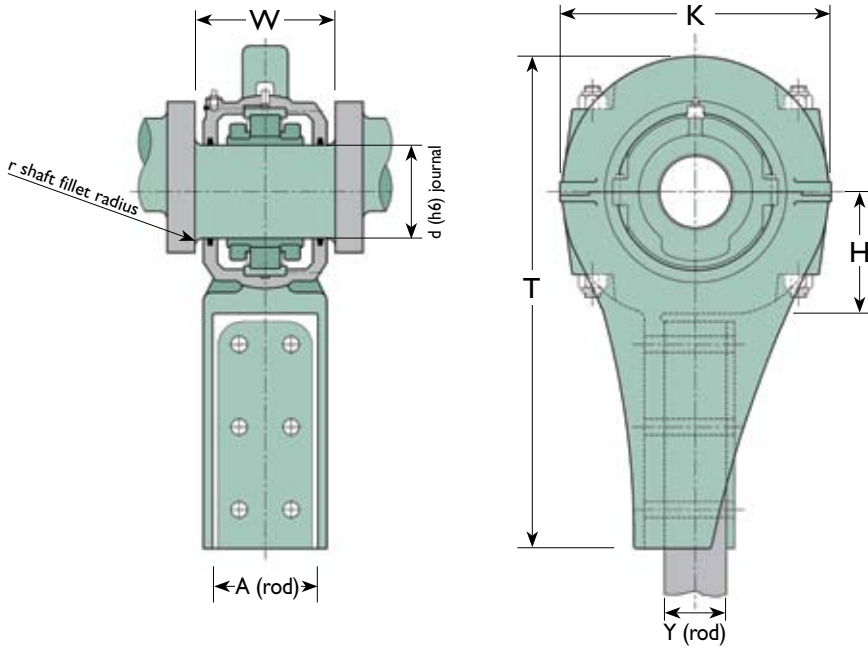

Reference (1) (Complete unit)	Shaft Diameter d (mm)	W (mm)	r (max) (mm)	A(2) (rod) (mm)	Y(2) (rod) (mm)	H (mm)	K (mm)	T (mm)	Mass (Complete unit) (kg)
100 BCRES 140M		168	6	126	64	158	400	654	78
01 BCRES 140M	140	187	9.5	152	76	177	442	696	98
02 BCRES 140M		213	12.5	152	76	177	442	696	145
100 BCRES 150M		187	9.5	152	76	177	442	696	91
01 BCRES 150M	150	193	9.5	152	76	177	442	696	107
02 BCRES 150M		229	12.5	152	64	203	444	736	166
01 BCRES 155M	155	193	9.5	152	76	177	442	696	107
02 BCRES 155M		229	12.5	152	64	203	444	736	166

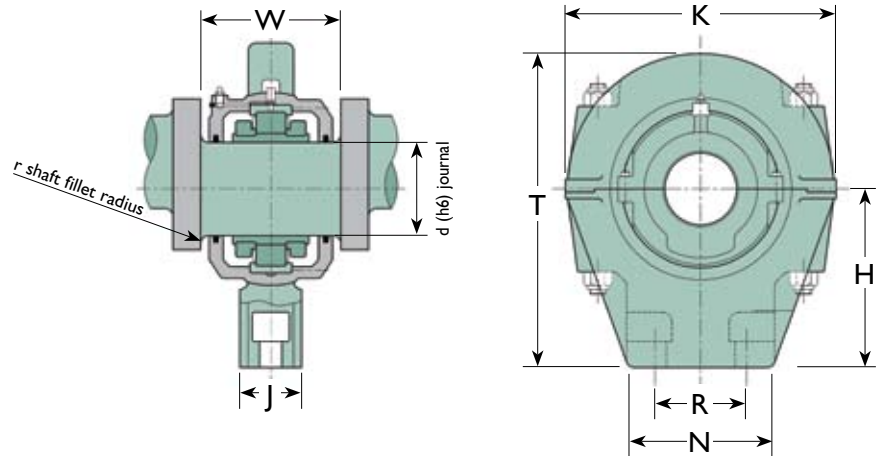

Shaft Diameter d (in)	Reference (1) (Complete unit)	W (mm)	r (max) (mm)	N (mm)	J (mm)	H (mm)	K (mm)	T (mm)	R (mm)	Bolts	Mass (Complete unit) (kg)
1 ³ / ₁₆	01 BCRET 103	92	3	86	30	76	140	152	57(2)	M12	6
1 ⁴ / ₁₆	01 BCRET 104	92	3	86	30	76	140	152	57(2)	M12	6
1 ⁷ / ₁₆	01 BCRET 107	92	3	86	30	76	140	152	57(2)	M12	6
1 ¹ / ₂	01 BCRET 108	92	3	86	30	76	140	152	57(2)	M12	6
1 ¹¹ / ₁₆	01E BCRET 111	104	3	102	32	102	166	190	70	M10	8
1 ³ / ₄	01E BCRET 112	104	3	102	32	102	166	190	70	M10	8
1 ¹⁵ / ₁₆	01E BCRET 115	104	3	102	32	102	166	190	70	M10	8
	02 BCRET 115	123	4.5	115	38	95	197	194	76(2)	M16	9
2	01E BCRET 200	104	3	102	32	102	166	190	70	M10	8
	02 BCRET 200	123	4.5	115	38	95	197	194	76(2)	M16	9
2 ³ / ₁₆	01E BCRET 203	113	4.5	115	38	95	197	194	76(2)	M16	9
	02 BCRET 203	138	6	128	44	108	216	220	89(2)	M16	13
2 ¹ / ₄	01E BCRET 204	113	4.5	115	38	95	197	194	76(2)	M16	9
	02 BCRET 204	138	6	128	44	108	216	220	89(2)	M16	13

(1) For (matched) rod end and cartridge only without roller bearing remove 'B' from reference, e.g. 01 CRET 107

For (standard rod-end specification) bearing only remove 'CRET' from reference and add 'GR C2', e.g. 01 B 107 GR C2

(2) Holes tapped in end face

INCH-SIZE ROD-END BEARING UNITS T TYPE TO 3³/₁₆" BORE SIZE

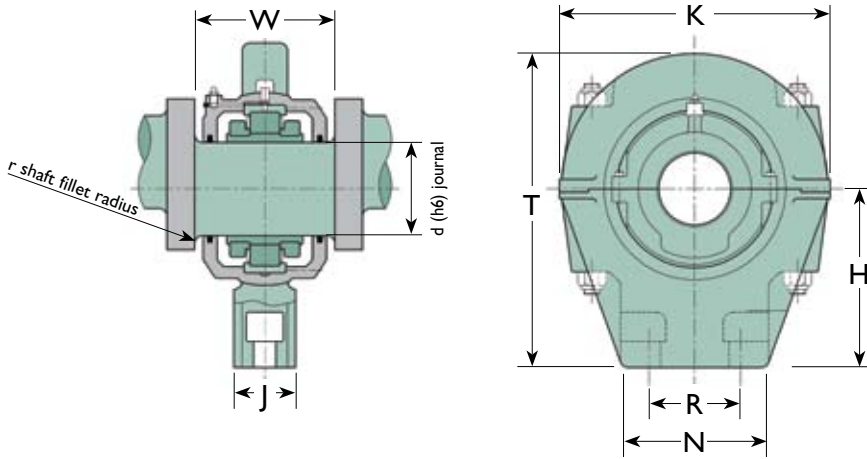

Shaft Diameter d (in)	Reference (1) (Complete unit)	W (mm)	r (max) (mm)	N (mm)	J (mm)	H (mm)	K (mm)	T (mm)	R (mm)	Bolts	Mass (Complete unit) (kg)
2 ¹ / ₁₆	01E BCRET 207	113	4.5	115	38	95	197	194	76(2)	M16	9
	02 BCRET 207	138	6	128	44	108	216	220	89(2)	M16	13
2 ¹ / ₂	01E BCRET 208	113	4.5	115	38	95	197	194	76(2)	M16	9
	02 BCRET 208	138	6	128	44	108	216	220	89(2)	M16	13
2 ¹¹ / ₁₆	01E BCRET 211	126	6	128	44	108	216	220	89(2)	M16	13
	02 BCRET 211	152	6	146	48	127	248	256	102(2)	M20	20
2 ³ / ₄	01E BCRET 212	126	6	128	44	108	216	220	89(2)	M16	13
	02 BCRET 212	152	6	146	48	127	248	256	102(2)	M20	20
2 ¹⁵ / ₁₆	100 BCRET 215	113	4.5	115	38	95	197	194	76(2)	M16	9
	01E BCRET 215	126	6	128	44	108	216	220	89(2)	M16	13
	02 BCRET 215	152	6	146	48	127	248	256	102(2)	M20	20
3	100 BCRET 300	113	4.5	115	38	95	197	194	76(2)	M16	9
	01E BCRET 300	126	6	128	44	108	216	220	89(2)	M16	13
	02 BCRET 300	152	6	146	48	127	248	256	102(2)	M20	20
3 ³ / ₁₆	01E BCRET 303	148	6	146	48	127	248	256	102(2)	M20	20
	02 BCRET 303	173	9.5	170	76	200	308	356	124	M24	36

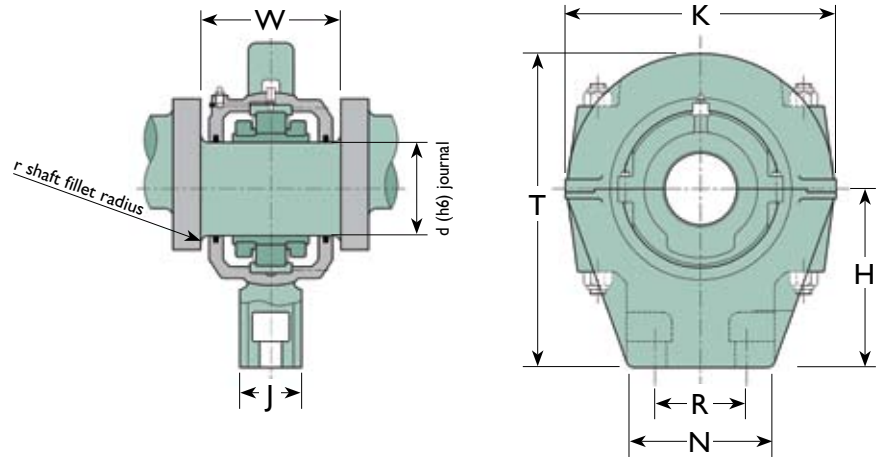

Shaft Diameter d (in)	Reference (1) (Complete unit)	W (mm)	r (max) (mm)	N (mm)	J (mm)	H (mm)	K (mm)	T (mm)	R (mm)	Bolts	Mass (Complete unit) (kg)
3/4	01E BCRET 304	148	6	146	48	127	248	256	102(2)	M20	20
	02 BCRET 304	173	9.5	170	76	200	308	356	124	M24	36
3/16	100 BCRET 307	126	6	128	44	108	216	220	89(2)	M16	13
	01E BCRET 307	148	6	146	48	127	248	256	102(2)	M20	20
	02 BCRET 307	173	9.5	170	76	200	308	356	124	M24	36
3/2	01E BCRET 308	148	6	146	48	127	248	256	102(2)	M20	20
	02 BCRET 308	173	9.5	170	76	200	308	356	124	M24	36
3 11/16	01E BCRET 311	146	6	170	76	200	308	356	124	M24	36
	02 BCRET 311	171	12.5	190	86	222	334	390	136	M30	52
3 3/4	01E BCRET 312	146	6	170	76	200	308	356	124	M24	36
	02 BCRET 312	171	12.5	190	86	222	334	390	136	M30	52
3 15/16	100 BCRET 315	148	6	146	48	127	248	256	102(2)	M20	19
	01E BCRET 315	146	6	170	76	200	308	356	124	M24	36
	02 BCRET 315	171	12.5	190	86	222	334	390	136	M30	52
4	100 BCRET 400	148	6	146	48	127	248	256	102(2)	M20	19
	01E BCRET 400	146	6	170	76	200	308	356	124	M24	36
	02 BCRET 400	171	12.5	190	86	222	334	390	136	M30	52

(1) For (matched) rod end and cartridge only without roller bearing remove 'B' from reference, e.g. 01 CRET 407

For (standard rod-end specification) bearing only remove 'CRET' from reference and add 'GR C2', e.g. 01 B 407 GR C2

(2) Holes tapped in end face

INCH-SIZE ROD-END BEARING UNITS T TYPE FROM 3¼" TO 5¾" BORE SIZE

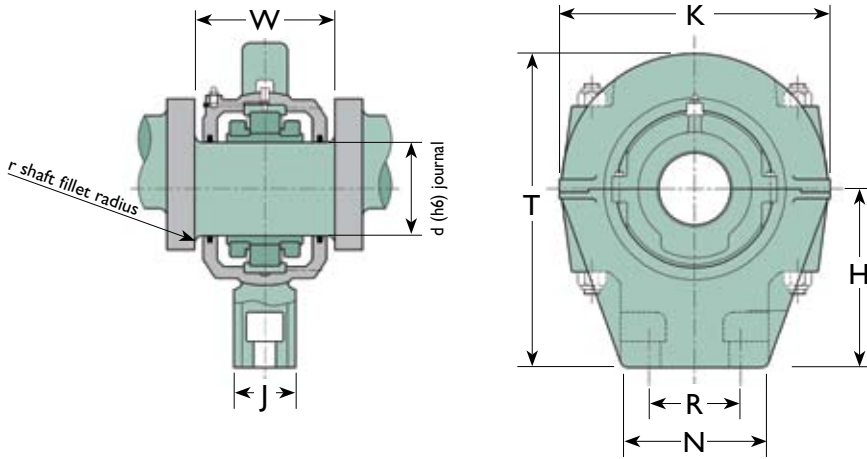

Shaft Diameter d (in)	Reference (1) (Complete unit)	W (mm)	r (max) (mm)	N (mm)	J (mm)	H (mm)	K (mm)	T (mm)	R (mm)	Bolts	Mass (Complete unit) (kg)
4¾	01 BCRET 403	154	6	190	86	222	334	390	136	M30	52
	02 BCRET 403	187	12.5	190	86	222	375	425	136	M30	65
4½	100 BCRET 407	146	6	170	76	200	308	356	124	M24	35
	01 BCRET 407	154	6	190	86	222	334	390	136	M30	52
	02 BCRET 407	187	12.5	190	86	222	375	425	136	M30	65
4½	100 BCRET 408	146	6	170	76	200	308	356	124	M24	35
	01 BCRET 408	154	6	190	86	222	334	390	136	M30	52
	02 BCRET 408	187	12.5	190	86	222	375	425	136	M30	65
4¼	100 BCRET 415	154	6	190	86	222	334	390	136	M30	48
	01 BCRET 415	168	6	190	86	222	375	425	136	M30	65
	02 BCRET 415	209	12.5	204	102	279	442	502	140	M30	99
5	100 BCRET 500	154	6	190	86	222	334	390	136	M30	48
	01 BCRET 500	168	6	190	86	222	375	425	136	M30	65
	02 BCRET 500	209	12.5	204	102	279	442	502	140	M30	99
5¾	01 BCRET 503	187	9.5	204	102	279	442	502	140	M30	89
	02 BCRET 503	213	12.5	204	102	279	445	558	140	M30	119

INCH-SIZE ROD-END BEARING UNITS T TYPE OVER 5³/₁₆" BORE SIZE

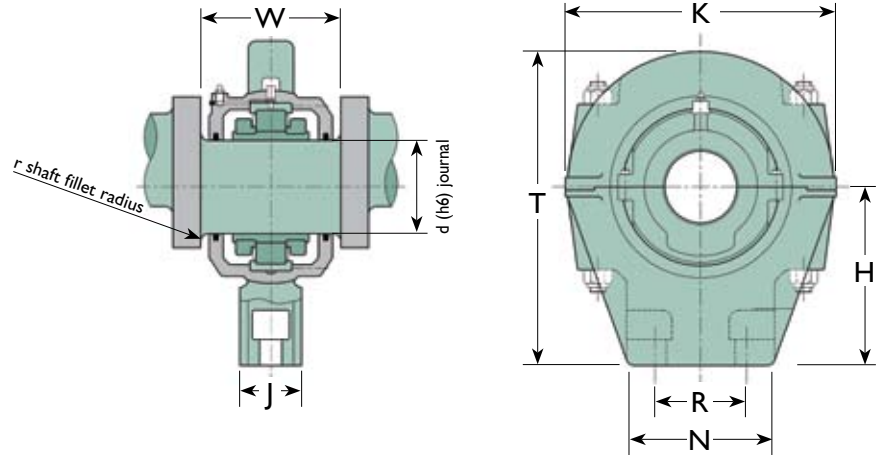

Shaft Diameter d (in)	Reference (1) (Complete unit)	W (mm)	r (max) (mm)	N (mm)	J (mm)	H (mm)	K (mm)	T (mm)	R (mm)	Bolts	Mass (Complete unit) (kg)
5 ⁷ / ₁₆	100 BCRET 507	168	6	190	86	222	375	425	136	M30	60
	01 BCRET 507	187	9.5	204	102	279	442	502	140	M30	89
	02 BCRET 507	213	12.5	204	102	279	445	558	140	M30	119
5 ¹ / ₂	100 BCRET 508	168	6	190	86	222	375	425	136	M30	60
	01 BCRET 508	187	9.5	204	102	279	442	502	140	M30	89
	02 BCRET 508	213	12.5	204	102	279	445	558	140	M30	119
5 ¹⁵ / ₁₆	100 BCRET 515	187	9.5	204	102	279	442	502	140	M30	82
	01 BCRET 515	193	9.5	204	102	279	442	502	140	M30	99
	02 BCRET 515	229	12.5	204	102	279	445	558	140	M30	131
6	100 BCRET 600	187	9.5	204	102	279	442	502	140	M30	82
	01 BCRET 600	193	9.5	204	102	279	442	502	140	M30	99
	02 BCRET 600	229	12.5	204	102	279	445	558	140	M30	131

- (1) For (matched) rod end and cartridge only without roller bearing remove 'B' from reference, e.g. 01 CRET 507
For (standard rod-end specification) bearing only remove 'CRET' from reference and add 'GR C2', e.g. 01 B 507 GR C2

INCH-SIZE ROD-END BEARING UNITS SHOE TYPE TO 2¼" BORE SIZE

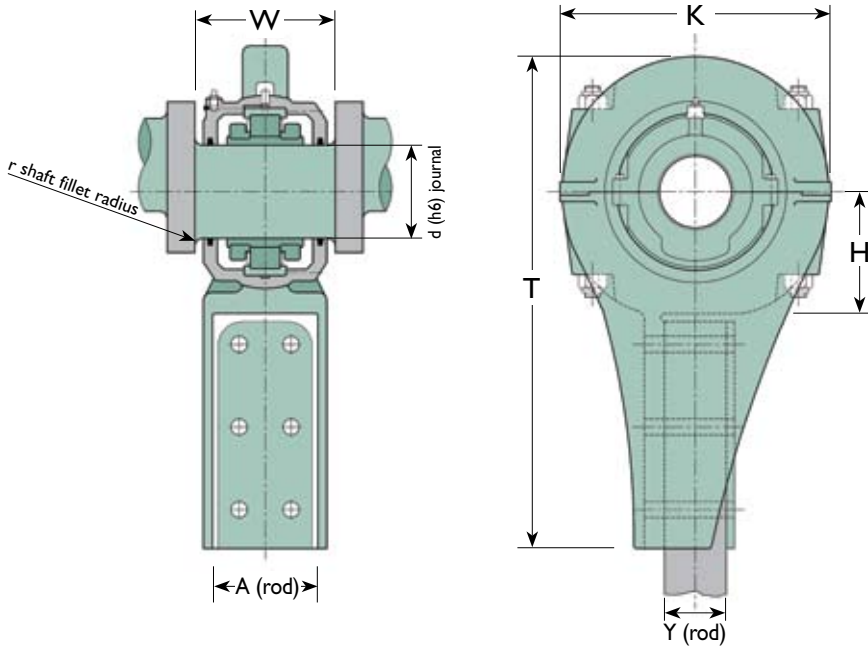

Shaft Diameter d (in)	Reference (1) (Complete unit)	W (mm)	r (max) (mm)	A(2) (rod) (mm)	Y(2) (rod) (mm)	H (mm)	K (mm)	T (mm)	Mass (Complete unit) (kg)
1⅜	01 BCRES 103	92	3	62	10	65	160	258	5
1¼	01 BCRES 104	92	3	62	10	65	160	258	5
1⅞	01 BCRES 107	92	3	62	10	65	160	258	5
1½	01 BCRES 108	92	3	62	10	65	160	258	5
1⅞	01E BCRES 111	104	3	62	10	70	166	308	7
1¾	01E BCRES 112	104	3	62	10	70	166	308	7
1⅝	01E BCRES 115	104	3	62	10	70	166	308	7
	02 BCRES 115	123	4.5	62	32	76	190	330	10
2	01E BCRES 200	104	3	62	10	70	166	308	7
	02 BCRES 200	123	4.5	62	32	76	190	330	10
2⅜	01E BCRES 203	113	4.5	62	10	79	190	330	13
	02 BCRES 203	138	6	88	50	108	248	432	20
2¼	01E BCRES 204	113	4.5	62	10	79	190	330	13
	02 BCRES 204	138	6	88	50	108	248	432	20

(1) For (matched) rod end and cartridge only without roller bearing remove 'B' from reference, e.g. 01 CRES 107
For (standard rod-end specification) bearing only remove 'CRES' from reference and add 'GR C2', e.g. 01 B 107 GR C2

(2) Rod fixing varies from 2 to 6 bolts according to size, and can be adapted to requirements

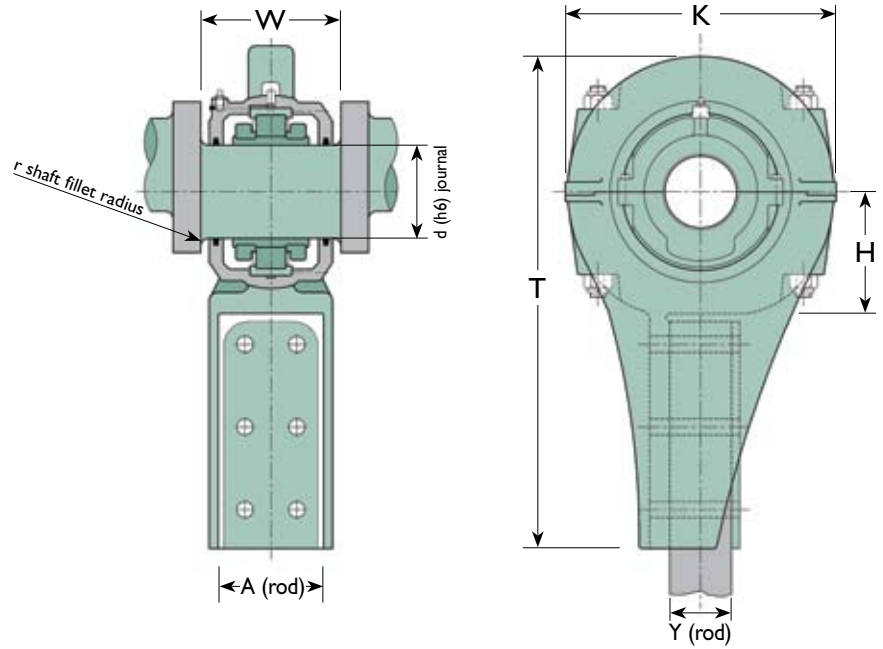

Shaft Diameter d (in)	Reference (1) (Complete unit)	W (mm)	r (max) (mm)	A(2) (rod) (mm)	Y(2) (rod) (mm)	H (mm)	K (mm)	T (mm)	Mass (Complete unit) (kg)
2 ¹ / ₁₆	01E BCRES 207	113	4.5	62	10	79	190	330	13
	02 BCRES 207	138	6	88	50	108	248	432	20
2 ¹ / ₂	01E BCRES 208	113	4.5	62	10	79	190	330	13
	02 BCRES 208	138	6	88	50	108	248	432	20
2 ¹¹ / ₁₆	01E BCRES 211	126	6	88	50	108	248	432	22
	02 BCRES 211	152	6	114	38	130	248	540	40
2 ³ / ₄	01E BCRES 212	126	6	88	50	108	248	432	22
	02 BCRES 212	152	6	114	38	130	248	540	40
2 ⁵ / ₁₆	100 BCRES 215	113	4.5	62	10	79	190	330	13
	01E BCRES 215	126	6	88	50	108	248	432	22
	02 BCRES 215	152	6	114	38	130	248	540	40
3	100 BCRES 300	113	4.5	62	10	79	190	330	13
	01E BCRES 300	126	6	88	50	108	248	432	22
	02 BCRES 300	152	6	114	38	130	248	540	40

(1) For (matched) rod end and cartridge only without roller bearing remove 'B' from reference, e.g. 01E CRES 207
For (standard rod-end specification) bearing only remove 'CRES' from reference and add 'GR C2', e.g. 01E B 207 GR C2

(2) Rod fixing varies from 2 to 6 bolts according to size, and can be adapted to requirements

INCH-SIZE ROD-END BEARING UNITS SHOE TYPE FROM 2⁷/₁₆ UP TO 3¹⁵/₁₆" BORE SIZE

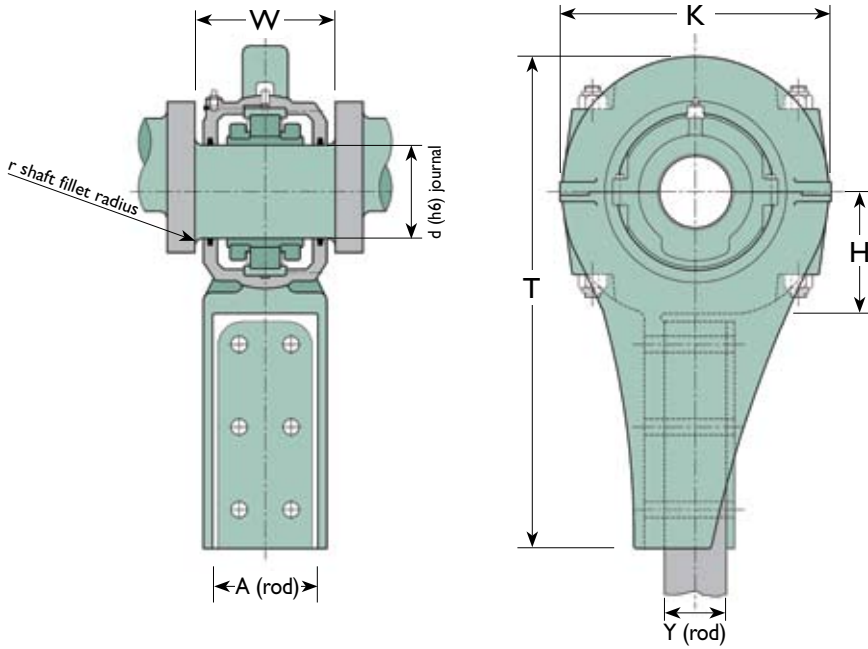

Shaft Diameter d (in)	Reference (1) (Complete unit)	W (mm)	r (max) (mm)	A(2) (rod) (mm)	Y(2) (rod) (mm)	H (mm)	K (mm)	T (mm)	Mass (Complete unit) (kg)
3 ³ / ₁₆	01E BCRES 303	148	6	100	50	133	264	602	43
	02 BCRES 303	173	9.5	126	76	149	334	610	62
3 ¹ / ₄	01E BCRES 304	148	6	100	50	133	264	602	43
	02 BCRES 304	173	9.5	126	76	149	334	610	62
3 ⁷ / ₁₆	100 BCRES 307	126	6	88	50	108	248	432	23
	01E BCRES 307	148	6	100	50	133	264	602	43
	02 BCRES 307	173	9.5	126	76	149	334	610	62
3 ¹ / ₂	01E BCRES 308	148	6	100	50	133	264	602	43
	02 BCRES 308	173	9.5	126	76	149	334	610	62
3 ¹¹ / ₁₆	01E BCRES 311	146	6	100	58	125	308	572	44
	02 BCRES 311	171	12.5	126	76	149	354	618	71
3 ³ / ₄	01E BCRES 312	146	6	100	58	125	308	572	44
	02 BCRES 312	171	12.5	126	76	149	354	618	71
3 ¹⁵ / ₁₆	100 BCRES 315	148	6	114	38	130	248	540	36
	01E BCRES 315	146	6	100	58	125	308	572	44
	02 BCRES 315	171	12.5	126	76	149	354	618	71

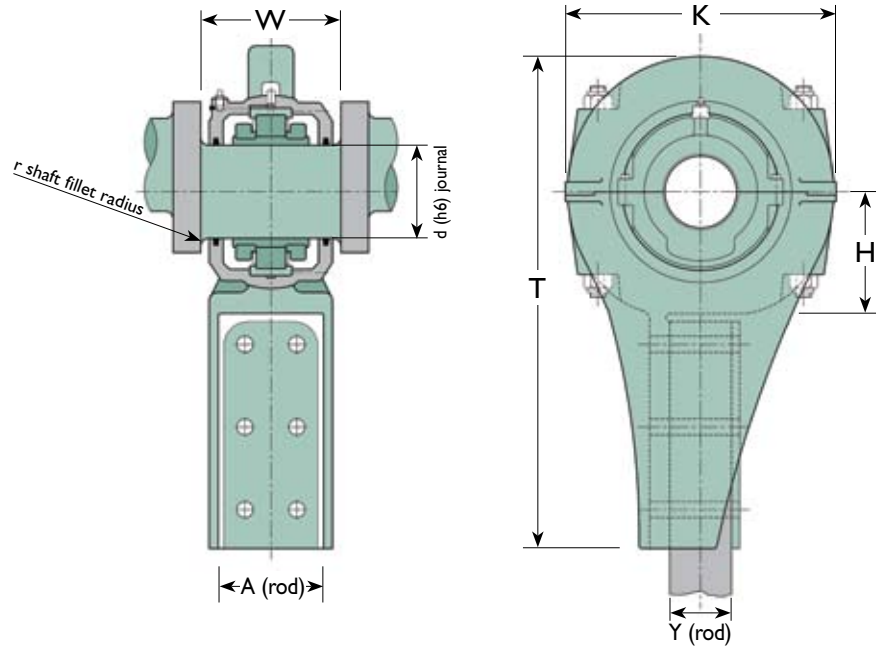

Shaft Diameter d (in)	Reference (1) (Complete unit)	W (mm)	r (max) (mm)	A(2) (rod) (mm)	Y(2) (rod) (mm)	H (mm)	K (mm)	T (mm)	Mass (Complete unit) (kg)
4	100 BCRES 400	148	6	114	38	130	248	540	36
	01E BCRES 400	146	6	100	58	125	308	572	44
	02 BCRES 400	171	12.5	126	76	149	354	618	71
4 ³ / ₁₆	01 BCRES 403	154	6	126	58	149	354	618	63
	02 BCRES 403	187	12.5	126	76	162	400	654	91
4 ⁷ / ₁₆	100 BCRES 407	146	6	100	58	125	308	572	43
	01 BCRES 407	154	6	126	58	149	354	618	63
	02 BCRES 407	187	12.5	126	76	162	400	654	91
4 ¹ / ₂	100 BCRES 408	146	6	100	58	125	308	572	43
	01 BCRES 408	154	6	126	58	149	354	618	63
	02 BCRES 408	187	12.5	126	76	162	400	654	91
4 ¹⁵ / ₁₆	100 BCRES 415	154	6	126	58	149	354	618	59
	01 BCRES 415	168	6	126	64	158	400	654	83
	02 BCRES 415	209	12.5	152	76	177	442	696	124

(1) For (matched) rod end and cartridge only without roller bearing remove 'B' from reference, e.g. 01 CRES 407

For (standard rod-end specification) bearing only remove 'CRES' from reference and add 'GR C2', e.g. 01 B 407 GR C2

(2) Rod fixing varies from 2 to 6 bolts according to size, and can be adapted to requirements

INCH-SIZE ROD-END BEARING UNITS SHOE TYPE OVER 3¹⁵/₁₆" BORE SIZE

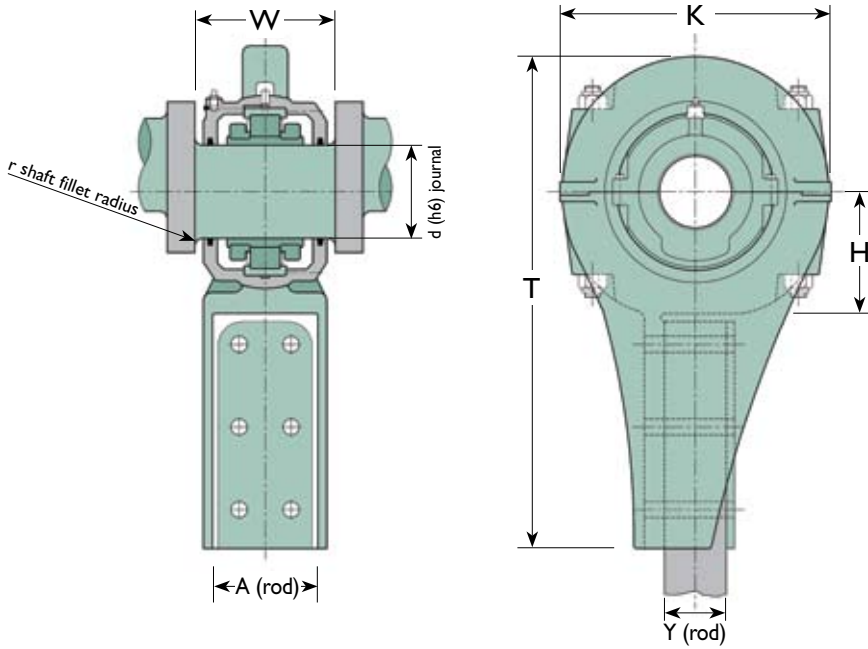

Shaft Diameter d (in)	Reference (1) (Complete unit)	W (mm)	r (max) (mm)	A(2) (rod) (mm)	Y(2) (rod) (mm)	H (mm)	K (mm)	T (mm)	Mass (Complete unit) (kg)
5	100 BCRES 500	154	6	126	58	149	354	618	59
	01 BCRES 500	168	6	126	64	158	400	654	83
	02 BCRES 500	209	12.5	152	76	177	442	696	124
5 ³ / ₁₆	01 BCRES 503	187	9.5	152	76	177	442	696	98
	02 BCRES 503	213	12.5	152	76	177	442	696	145
5 ⁷ / ₁₆	100 BCRES 507	168	6	126	64	158	400	654	78
	01 BCRES 507	187	9.5	152	76	177	442	696	98
	02 BCRES 507	213	12.5	152	76	177	442	696	145
5 ¹ / ₂	100 BCRES 508	168	6	126	64	158	400	654	78
	01 BCRES 508	187	9.5	152	76	177	442	696	98
	02 BCRES 508	213	12.5	152	76	177	442	696	145
5 ¹⁵ / ₁₆	100 BCRES 515	187	9.5	152	76	177	442	696	91
	01 BCRES 515	193	9.5	152	76	177	442	696	107
	02 BCRES 515	229	12.5	152	64	203	444	736	166
6	100 BCRES 600	187	9.5	152	76	177	442	696	91
	01 BCRES 600	193	9.5	152	76	177	442	696	107
	02 BCRES 600	229	12.5	152	64	203	444	736	166

Bearings of large bore size

The following table lists some of the bearings over 600mm/24" bore size manufactured by Cooper recently.

This table may be used as a guide for selecting or designing-in large bore bearings, but it should be borne in mind that these larger sizes of bearing are frequently adapted to meet application requirements. They may be modified to match existing or required envelopes and capacities. Many of the bearings may be supplied with slightly different bore sizes to those under which they are listed, while alternative versions may already be available at some bore sizes without modification.

Generally, these bearing are available in expansion 'EX' or fixed 'GR' types (see page 4). Extra-expansion 'EXILOG' types (see page 6) are also made regularly, but often have different envelope dimensions (in particular, the inner race is usually wider).

Lighter duty 04 Series bearings are shown separately on page 148.

It is always advisable to contact Cooper when specifying large bearings.

Housings

If the bearing is to be mounted in a housing made by the equipment manufacturer, Cooper will supply details of the required mounting tolerances upon request.

If the bearing is to be fitted into an existing housing, accurate details of the mounting dimensions should be supplied to Cooper to ensure compatibility.

Cooper can supply suitable housings, including cartridges, pedestals, flanges, and custom housings for large bearings. (See other sections for explanations of these housing types). Please contact Cooper with application details so that we can supply details of the most suitable housing, or design or adapt a housing to suit if required.

Double Bearings

Large bearings are often paired to form a 'double bearing' of increased capacity.

To calculate the dynamic capacity of a double bearing, multiply the dynamic capacity (C_r) of the single bearing by 1.714.

To calculate the static capacity of the double bearing, multiply the static capacity (C_{or}) of the single bearing by 2.

Mountings for double bearings should be designed to equalise the loading on the two rows of rollers.

Bearings should only be mounted together to form a two-row bearing if they are supplied by Cooper specifically for this purpose, and the bearings should be maintained in their allocated pairings.

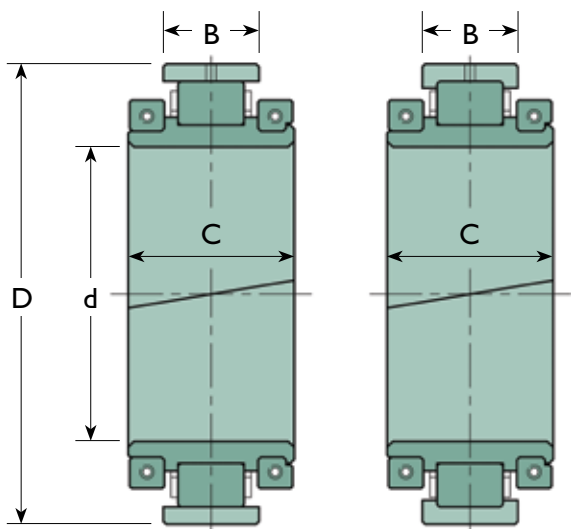

Shaft Diameter d		References	D (mm)	C (mm)	B (mm)	Cr (kN)	Cor (kN)
(mm)	(in)						
610		01 B 610M	780	172	84.1	1431	3311
613.2		03E B 613.2M	980	370(1)	200(1)	5593	9863
630		01 B 630M	794	190	88	1780	4181
	25	02 B 2500	866.78	219.08	117.48	2724	5833
650		02 B 650M	860	220	120	2724	5833
		03E B 650M	980	320	200	5738	11253
660		02 B 660M	866.78	219.08	117.48	2724	5833
	26	03E B 2600	980	320	200	5738	11253
	27	01 B 2700	864	170	94	1761	4014
690		01 B 690M	864	170	94	1761	4014
710		01 B 710M	890	185	95	1817	4234
		02 B 710M	980	290	155	3530	7019
	28	01 B 2800	892.18	184.15	87.31	1682	4038

Shaft Diameter d		References	D (mm)	C (mm)	B (mm)	Cr (kN)	Cor (kN)
(mm)	(in)						
750		01 B 750M	971.55	206	101.6	2321	5685
		02 B 750M	990	240	140	3554	7582
		03 B 750M	1060	310	185	5173	10544
775		01 B 775M	945	165	80	1762	3974
850		01 B 850M	1046	200	106	2555	6401
950		01 B 950M	1172	220	120	3238	8209
	40	01 B 4000	1270	260	139.7	3958	10084
1150		4DS B 1150M	1490	305	175	5737	13445

(1) Dimensions of 03E B 613.2M refer to EXILOG type (refer to page 6)

04 Series Bearings

Cooper 04 Series bearings are specialised bearings for lighter duties at large bore sizes.

04 Series bearings are capable of high speeds, but are also used on lower speed applications. Use of these bearings at high speeds requires special attention to lubrication.

If the bearing is to be used at slow speeds only it may be possible to omit some of the 'high speed' features of the bearing, allowing a more economical bearing specification.

Shaft Diameter d		Reference	D (mm)	C (mm)	B (mm)	Cr (kN)	Cor (kN)	Max. Speed (rpm)	Mass (kg)
(mm)	(inches)								
6		04 B 600	257.18	79	38.1	198	246	3000	14
10 $\frac{3}{8}$		04 B 1010	365.13	103	48.4	336	367	2470	27
340		04 B 340M	438.15	103	48.4	261	282	1950	35
13 $\frac{1}{2}$		04 B 1308	438.15	103	48.4	261	282	1950	34
400		04 B 400M	505	100	36	214	235	1650	34
17 $\frac{1}{2}$		04 B 1708	546.1	108	48.4	302	367	1460	45
18 $\frac{1}{2}$		04 B 1808	571.5	108	48.4	316	395	1370	50
20 $\frac{3}{4}$		04 B 2012	635	114	48.4	326	423	1210	54
550		04 B 550M	655	98	36	266	289	1150	54
22		04 B 2200	666.75	101	38.1	361	452	1130	54
23		04 B 2300	692.15	101	38.1	368	470	1080	59
24		04 B 2400	717.55	101	38.1	413	543	1020	61
26 $\frac{1}{2}$		04 B 2608	781.05	114	48.4	509	818	910	77
30		04 B 3000	882.65	114	44.5	372	509	780	95
32		04 B 3200	939.8	114	44.5	394	579	730	104
33		04 B 3300	965.2	114	44.5	403	602	705	104
36		04 B 3600	1041.4	114	44.5	418	556	620	118
1060		04 B 1060M	1220	127	60	954	1472	560	180
44		04 B 4400	1295.4	168	76.2	1339	1822	140	200
48		04 B 4800	1371.6	140	69.9	1094	1693	350	146
1295		04 B 1295AM	1435.1	127	63.5	988	1606	340	193
1295		04 B 12965BM	1473.2	168	76.2	1831	2877	120	313
1550		04 B 1550M	1720	140	75	1364	2418	300	336

Generally, these bearing are available in expansion 'EX' or fixed 'GR' types (see page 4). Alternative configurations are possible where appropriate.

These bearings may be subjected to a degree of adaption to suit application requirements. They may also be supplied with slightly different bore sizes to those under which they are listed.

It is advisable to contact Cooper when specifying 04 Series bearings.

Housing

Most commonly, 04 Series bearings are mounted in customer's own housings or into housings integrated into the structure of the machine. Details of appropriate mounting tolerances can be supplied on request.

If it is wished for Cooper to supply bearings complete with housings, please contact us with application details.

In general, if operating conditions and envelope restrictions allow, it is more economical to supply 01 Series bearings complete with housings, as a greater range of standardised housings is available for the 01 Series.

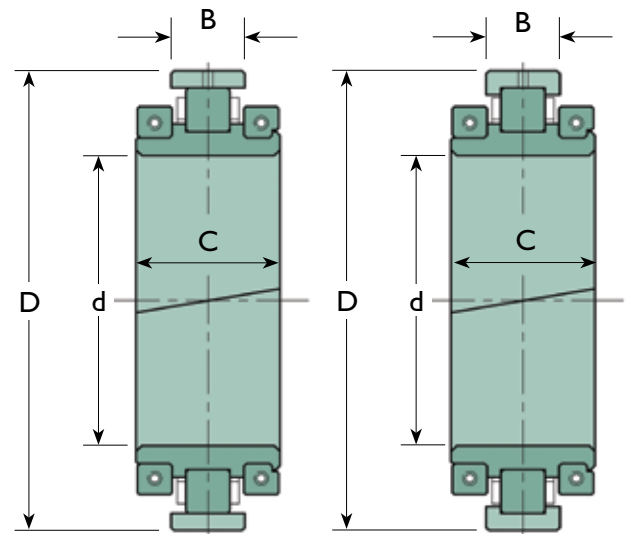



WATER-COOLED BEARINGS FOR CONTINUOUS CASTERS

Water-cooled Bearing Units

Water-cooled bearing units for continuous casting machines are generally customised to individual applications. Bearings are of the 071 or 081 Series, which are designed specifically for this type of application. The general features of a typical design are illustrated below.

Bearings of the type illustrated may also be applied to other slow moving applications (generally under 15rpm) where a high capacity bearing is required in a compact envelope.

If you wish to specify Cooper water-cooled bearing units, or bearings of the 071 or 081 Series, please contact our technical department with details of the application.

150

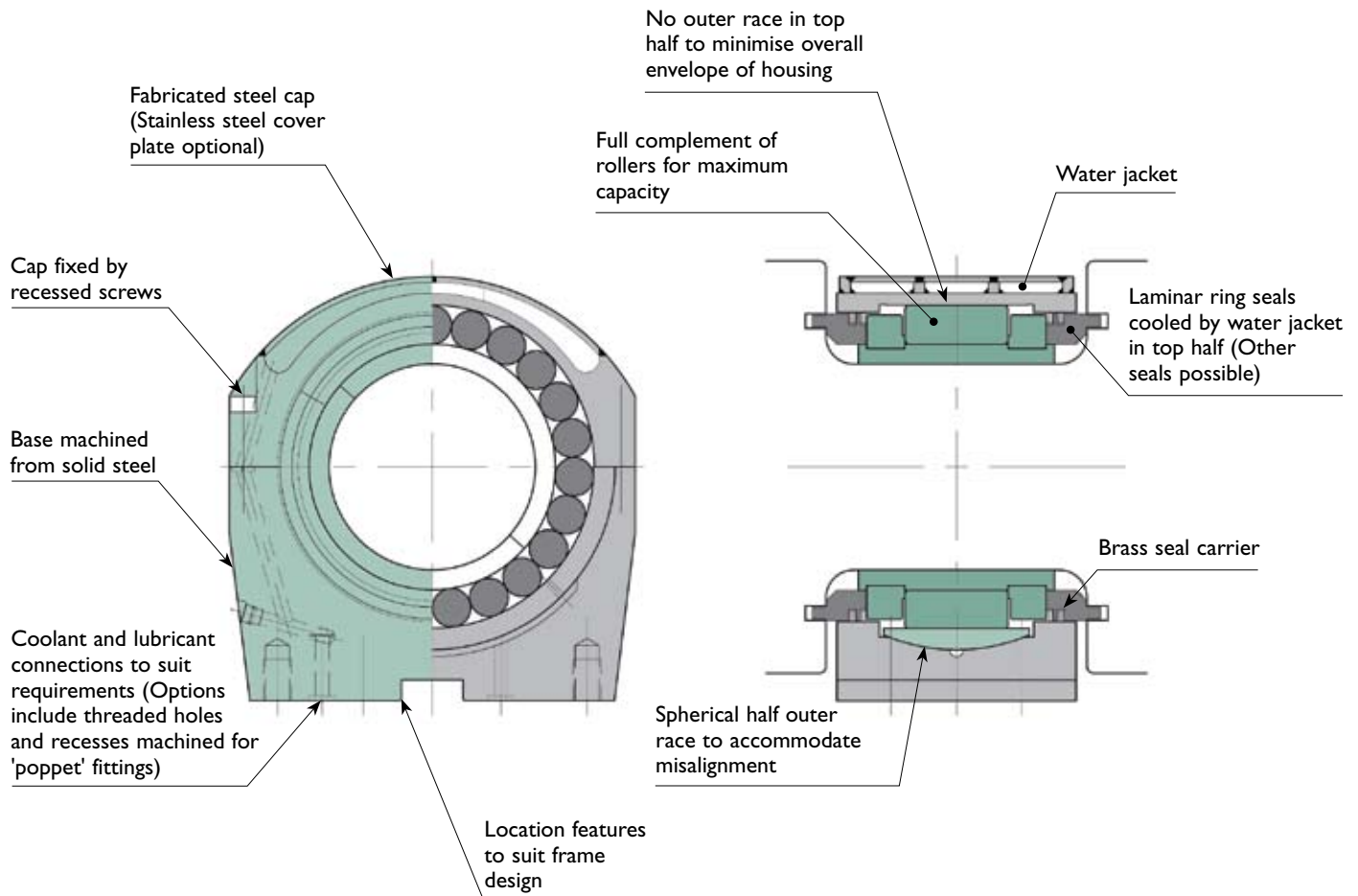

Cooper frequently supply special and customised bearings and housings. Customisations range from minor modifications, such as special holes for mounting instruments, to complete custom bearings and housing.

We have designs and tooling for many products that are not included in this catalogue and may suit your application. If not, we are able to design special units as required.

If you do not find a bearing or housing that meets your requirements in this catalogue, our technical department will be pleased to advise on a suitable product.

A selection of special products are illustrated on this page.

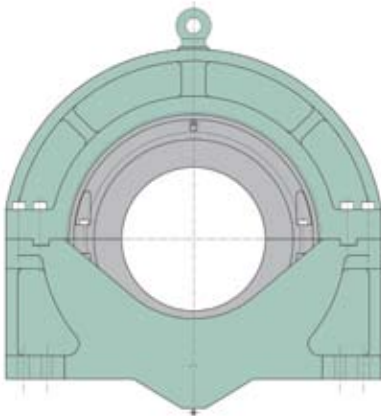

Bearing and cartridge in custom housing
(to be mounted on 2 plinths)

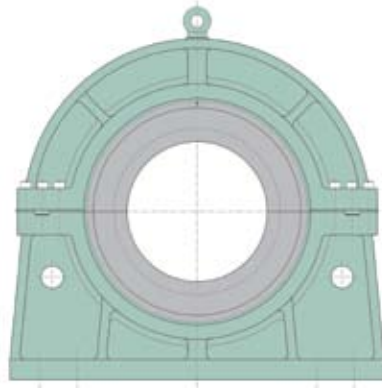

Double bearing in special cartridge and pedestal

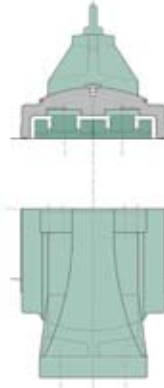

Double bearing to special dimensions with spacer ring
for outer race

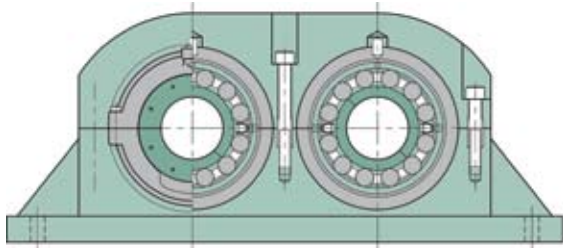

Special bearing unit for twin shafts

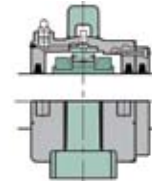

Small unit with extra seals

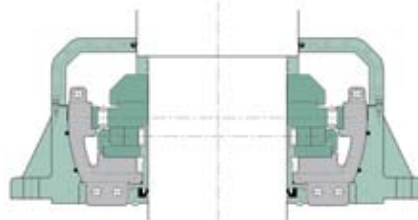

Combined radial and thrust bearing and housing



Special compact take-up unit

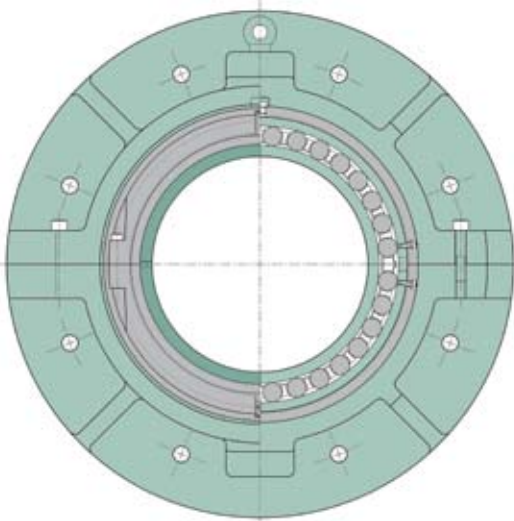
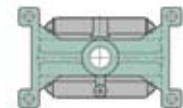

Large flange unit

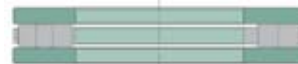

Solid flat thrust bearing

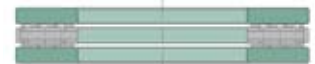

Split flat thrust bearing

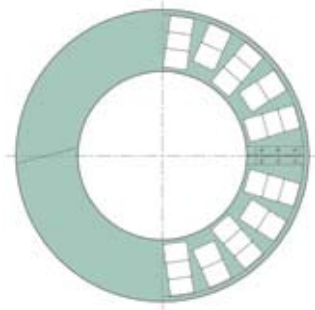
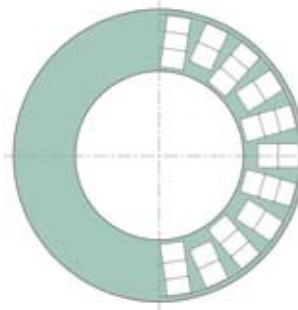

The following is a typical assembly sequence of a pedestal or flange mounted bearing and is included to allow engineers using this catalogue to understand the assembly process of the Cooper bearing and to allow them to produce relevant documentation for their own machines, which may require this information. A full set of assembly instructions is usually packaged with each standard bearing, for use by the fitters. If non-standard bearings are to be used, and/or a different assembly sequence is required for the application, specific assembly instructions can be supplied on request.

The illustrations use a pedestal mounted unit as an example.

Preliminary Notes

Bearings must be disassembled before assembling into position.

Unwrap the bearing parts, remove the outer race halves (if supplied assembled around other parts), and separate the halves of the cage (if required). Various cage jointing methods are used depending on size and series of bearing. Undo the clamping ring screws and remove the clamping rings from the inner race.

Remove the preservative from all surfaces of all the parts.

All bearing and housing components (with the exception of pressed steel-, die cast- and plastic cages) are marked with matching numbers or letters on each half. Ensure that the match marks on the halves are the same and are placed together on each component when the bearing is assembled.

Even though cage halves are not necessarily match-marked, they must not be mixed, as the rollers are graded into sets.

Complete roller bearings are interchangeable between similar Cooper cartridges. Individual parts should not be interchanged. Cartridges are interchangeable between standard outer housings provided that standard clearances are specified.

Step 1 – Housing Base

Place the pedestal base or flange lower half into position. If the precise location of the housing is predetermined it may be bolted into position. Generally, pedestal bases may require slight movement at a later stage in order to accurately position the shaft.

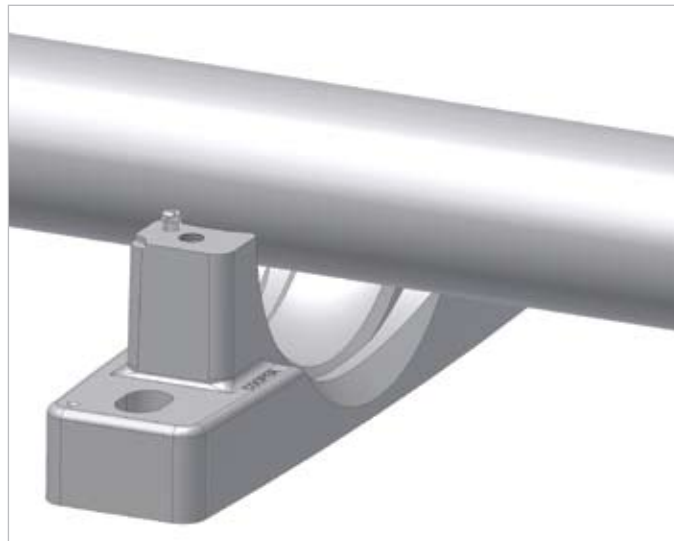

Note: The pedestal base is not shown in most of the illustrations that follow, for clarity of other details.

Step 2 – Inner Race

Lightly oil the shaft with thin machine oil, then remove the excess with a clean wiper. Place the inner race at the correct position on the cleaned shaft. Soft packing on the joint faces, or feeler gauges, should be used to ensure that the joint gaps are approximately equal. Inner races of expansion bearings are usually set centrally with the outer race, but in cases of significant axial expansion there may be a deliberate offset. (This is usually up to a maximum of 10% of the roller length, but may be more in the case of special types of bearing).



Step 3 – Clamping Rings

Fit the clamping rings with joints at approximately 90° to the inner race joints (45° in the case of large bearings with 4-part clamping rings). Progressively tighten all clamping ring screws.



Tap down each half of the inner race and clamping rings all around the shaft using a soft-faced hammer, or insert a hardwood block between a steel hammer and the bearing parts. Retighten the clamping ring screws. Repeat until screws remain fully tight. Tightening torques are listed on pages 156 to 160.



Check that there are approximately equal gaps at both joints of the inner race.

Check that there are approximately equal joints at both (or all 4) joints of each clamping ring.

Step 4 – Cage and Rollers

Coat the bore of the cage and roller assembly with grease and lightly cover the inner race assembly (fitted to the shaft) all over with grease for protection.

Assemble the cage (complete with rollers) around the inner race. The two halves of the cage are fixed together by various means depending on size and series of bearing. (Further details are to be found in the assembly leaflets supplied with the bearing, or details of the joint of a particular size and series of cage can be supplied on request).



Step 5 – Cartridge and Outer Race Sub-Assembly

Place the half outer race with the lubrication hole in the top half of the cartridge and the second half outer race into the lower half of the cartridge. Ensure that the ends of the outer race project from the cartridge joint face by equal amounts.

All lipped outer races must be clamped axially. Side screws 'A' are fitted to all GR cartridges. Side rods 'B' are fitted to some sizes only.

Radial screws 'C' and washers are fitted to both EX and GR cartridges of larger sizes only.



EX Cartridges:

Just enter radial screws 'C' (where fitted, complete with washers) into the corresponding outer race holes, but do not tighten. Place the two half cartridges together, complete with half outer races, and fully tighten the joint screws 'D'. Fully tighten the radial screws 'C'.

Cartridges for Lipped Outer Races (GR and Special Types):

Just enter radial screws 'C' (where fitted, complete with washers) into the corresponding outer race holes, but do not tighten. Place the two half cartridges together, complete with outer races, and fully tighten the joint screws 'D'. Enter the side rods 'B' (where fitted) and side screws 'A'. Progressively and fully tighten the side screws 'A' and radial screws 'C' (where fitted).

All types:

Inject grease to fill the grease passages. Remove joint screws 'D' and separate cartridge halves, taking care that the outer race halves do not fall out of position in their respective half-cartridges.

Step 6 – Seals

If the unit is to be fitted with aluminium triple labyrinth (ATL) seals, fit them onto the shaft as follows:

Separate the ATL seal halves by driving out the two joining pins. Lubricate the 'O' rings in the bore with grease. Reassemble on the shaft by compressing the 'O' rings of both halves sufficiently to allow the joining pins to be reinserted, and reinsert the pins. Note: ATL seals are able to slide along the shaft once assembled



Felt seals should be soaked in oil before fitting into the cartridge end bores. Most types of seal other than triple labyrinth seals and SRSRP seals are fitted into the cartridge end bores before assembling the cartridge into position.

Step 7 – Lubrication

Coat the inside of the cartridge, cage and rollers and all seals with grease (See page 161 for correct quantity). For speeds over 150,000mm dn (shaft diameter in mm multiplied by shaft speed in rpm) approximately 40% of the grease used should be applied to the bearing parts and the remainder applied to the inside of the cartridge. This is to avoid excessive churning of grease when running at high speed.

Step 8 – Cartridge

Lubricate the spherical seating of the bottom half of the cartridge with grease.

Place the bottom half of the cartridge on top of the bearing and rotate 180° into the pedestal base or half-flange.

Place the top half of the cartridge on top of the bottom half, close the cartridge and fully tighten the joint screws. Lubricate the spherical seating with grease.

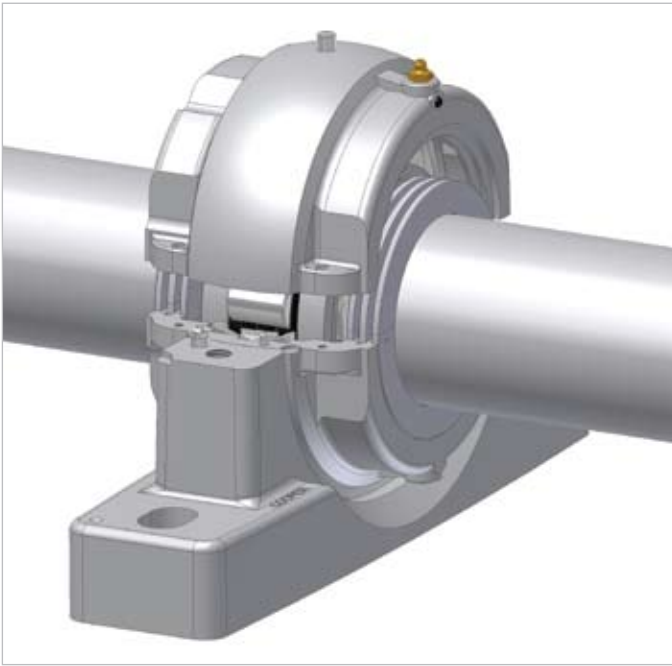

Step 9 – Housing

If not already done, tighten the bolts fixing the pedestal base or lower flange half into position.

Place the pedestal cap or flange top half into position. If it is safe to do so, running the shaft for a time without the outer housing joint screws fully tightened will help the bearing to accurately align.

Fully tighten the joint screws.



Shaft Diameter d (mm)	Bearing reference	Clamping ring screw (1)			Cartridge joint screw (1)			Cartridge radial screw (1)			Side screw (1)			Pedestal joint screw (1)			Flange joint screw (1)		
		Screw size	Key size A/F (mm)	Torque (2) (Nm)	Screw size	Key size A/F (mm)	Torque (Nm)	Screw size	Key size A/F (mm)	Torque (Nm)	Screw size	Key size A/F (mm)	Torque (Nm)	Screw size	Key size A/F (mm)	Torque (Nm)	Screw size	Key size A/F (mm)	Torque (Nm)
35	01 B 35M	M4x20	3	4.5	M4x25	3	3.5	-	-	-	M4x10	2	2.0	M8x45	6	26	M8x40	6	26
40	01 B 40M	M4x20	3	4.5	M4x25	3	3.5	-	-	-	M4x10	2	2.0	M8x45	6	26	M8x40	6	26
45	01E B 45M	M4x20	3	4.5	M4x25	3	3.5	-	-	-	M4x10	2	2.0	M8x45	6	26	M8x40	6	26
50	01E B 50M	M4x20	3	4.5	M4x25	3	3.5	-	-	-	M4x10	2	2.0	M8x45	6	26	M8x40	6	26
	02 B 50M	M5x25	4	8.5	M5x25	4	6.5	-	-	-	M4x10	2	2.0	M10x55	8	52.5	M10x45	8	52.5
55	01E B 55M	M4x20	3	4.5	M4x25	3	3.5	-	-	-	M4x10	2	2.0	M10x55	8	52.5	M10x45	8	52.5
60	01E B 60M	M4x20	3	4.5	M4x25	3	3.5	-	-	-	M4x10	2	2.0	M10x55	8	52.5	M10x45	8	52.5
	02 B 60M	M5x25	4	8.5	M5x25	4	6.5	-	-	-	M4x10	2	2.0	M12x65	10	90	M12x55	10	90
65	01E B 65M	M4x20	3	4.5	M4x25	3	3.5	-	-	-	M4x10	2	2.0	M10x55	8	52.5	M10x45	8	52.5
	02 B 65M	M5x25	4	8.5	M5x25	4	6.5	-	-	-	M4x10	2	2.0	M12x65	10	90	M12x55	10	90
70	01E B 70M	M4x20	3	4.5	M4x25	3	3.5	-	-	-	M4x10	2	2.0	M12x65	10	90	M12x55	10	90
	02 B 70M	M6x25	5	15	M6x25	5	11	-	-	-	M4x10	2	2.0	M16x65	14	225	M12x55	10	90
75	100 B 75M	M3x16	2.5	2	M4x25	3	3.5	-	-	-	M4x10	2	2.0	M10x55	8	52.5	M10x45	8	52.5
	01E B 75M	M4x20	3	4.5	M4x25	3	3.5	-	-	-	M4x10	2	2.0	M12x65	10	90	M12x55	10	90
	02 B 75M	M6x25	5	15	M6x25	5	11	-	-	-	M4x10	2	2.0	M16x65	14	225	M12x55	10	90
80	01E B 80M	M5x25	4	8.5	M5x25	4	6.5	-	-	-	M4x10	2	2.0	M16x65	14	225	M12x55	10	90
	02 B 80M	M6x25	5	15	M6x25	5	11	-	-	-	M4x10	2	2.0	M16x65	14	225	M16x65	14	225
85	100 B 85M	M4x20	3	4.5	M4x25	3	3.5	-	-	-	M4x10	2	2.0	M12x65	10	90	M12x55	10	90
	01E B 85M	M5x25	4	8.5	M5x25	4	6.5	-	-	-	M4x10	2	2.0	M16x65	14	225	M12x55	10	90
	02 B 85M	M6x25	5	15	M6x25	5	11	-	-	-	M4x10	2	2.0	M16x65	14	225	M16x65	14	225
90	01E B 90M	M5x25	4	8.5	M5x25	4	6.5	-	-	-	M4x10	2	2.0	M16x65	14	225	M12x55	10	90
	02 B 90M	M6x25	5	15	M6x25	5	11	-	-	-	M4x10	2	2.0	M16x65	14	225	M16x65	14	225
95	01E B 95M	M6x25	5	15	M6x25	5	11	-	-	-	M4x10	2	2.0	M16x65	14	225	M16x65	14	225
100	100 B 100M	M4x20	3	4.5	M5x25	4	6.5	-	-	-	M4x10	2	2.0	M16x65	14	225	M12x55	10	90
	01E B 100M	M6x25	5	15	M6x25	5	11	-	-	-	M4x10	2	2.0	M16x65	14	225	M16x65	14	225
	02 B 100M	M6x25	5	15	M6x25	5	11	-	-	-	M4x10	2	2.0	M20x80	17	420	M16x65	14	225
	03 B 100M	M10x45	8	70	M10x45	8	52.5	-	-	-	M6x10	3	7.8	M16x75	14	225	-	-	-
105	01E B 105M	M6x25	5	15	M6x25	5	11	-	-	-	M4x10	2	2.0	M16x65	14	225	M16x65	14	225
	02 B 105M	M6x25	5	15	M6x25	5	11	-	-	-	M4x10	2	2.0	M20x80	17	420	M16x65	14	225

(1) All screws are metric coarse thread, grade 12.9

(2) For vertical shaft or high thrust applications the clamping ring screw torque should be increased by up to 20%

INSTALLATION AND ASSEMBLY

SCREW SIZES, WRENCH SIZES AND TORQUES

Shaft Diameter (mm)	Bearing reference	Clamping ring screw (I)			Cartridge joint screw (I)			Cartridge radial screw (I)			Side screw (I)			Pedestal joint screw (I)			Flange joint screw (I)		
		Screw size	Key size A/F (mm)	Torque (Nm)	Screw size	Key size A/F (mm)	Torque (Nm)	Screw size	Key size A/F (mm)	Torque (Nm)	Screw size	Key size A/F (mm)	Torque (Nm)	Screw size	Key size A/F (mm)	Torque (Nm)	Screw size	Key size A/F (mm)	Torque (Nm)
110	100 B 110M	M5x25	4	8.5	M6x25	5	11	-	-	-	M4x10	2	2.0	M16x65	14	225	M16x65	14	225
	01 B 110M	M6x25	5	15	M6x25	5	11	-	-	-	M6x10	3	7.8	M20x80	17	420	M16x65	14	225
	02 B 110M	M8x30	6	35	M8x30	6	26	-	-	-	M6x10	3	7.8	M20x80	17	420	M20x80	17	420
	03 B 110M	M10x45	8	70	M10x45	8	52.5	M10x30	8	35	M6x10	3	7.8	M16x75	14	225	-	-	-
115	01 B 115M	M6x25	5	15	M6x25	5	11	-	-	-	M6x10	3	7.8	M20x80	17	420	M16x65	14	225
	02 B 115M	M8x30	6	35	M8x30	6	26	-	-	-	M6x10	3	7.8	M20x80	17	420	M20x80	17	420
120	100 B 120M	M6x25	5	15	M6x25	5	11	-	-	-	M6x10	3	7.8	M20x80	17	420	M16x65	14	225
	01 B 120M	M6x25	5	15	M6x25	5	11	-	-	-	M6x10	3	7.8	M20x80	17	420	M20x80	17	420
	02 B 120M	M8x30	6	35	M8x30	6	26	-	-	-	M6x10	3	7.8	M20x100	17	420	M20x100	17	420
	03 B 120M	M10x45	8	70	M10x45	8	52.5	M10x30	8	35	M6x10	3	7.8	M16x75	14	225	-	-	-
125	01 B 125M	M6x25	5	15	M6x25	5	11	-	-	-	M6x10	3	7.8	M20x80	17	420	M20x80	17	420
	02 B 125M	M8x30	6	35	M8x30	6	26	-	-	-	M6x10	3	7.8	M20x100	17	420	M20x100	17	420
130	100 B 130M	M6x25	5	15	M6x25	5	11	-	-	-	M6x10	3	7.8	M20x80	17	420	M16x65	14	225
	01 B 130M	M6x25	5	15	M6x25	5	11	-	-	-	M6x10	3	7.8	M20x80	17	420	M20x80	17	420
	02 B 130M	M8x30	6	35	M8x30	6	26	-	-	-	M6x10	3	7.8	M20x100	17	420	M20x100	17	420
	03 B 130M	M10x45	8	70	M10x45	8	52.5	M10x25	8	35	M10x16	5	30	M16x75	14	225	-	-	-
135	01 B 135M	M8x30	6	35	M8x30	6	26	-	-	-	M6x10	3	7.8	M20x80	17	420	M20x80	17	420
140	100 B 140M	M6x25	5	15	M6x25	5	11	-	-	-	M6x10	3	7.8	M20x80	17	420	M20x80	17	420
	01 B 140M	M8x30	6	35	M8x30	6	26	-	-	-	M6x10	3	7.8	M20x80	17	420	M20x80	17	420
	02 B 140M	M8x30	6	35	M8x30	6	26	-	-	-	M6x10	3	7.8	M20x100	17	420	M24x100	19	712
	03 B 140M	M10x45	8	70	M10x45	8	52.5	M10x25	8	35	M10x16	5	30	M20x100	17	420	-	-	-
145	02 B 145M	M8x30	6	35	M8x30	6	26	-	-	-	M6x10	3	7.8	M20x100	17	420	M24x100	19	712
150	100 B 150M	M6x25	5	15	M8x30	6	26	-	-	-	M6x10	3	7.8	M20x80	17	420	M20x80	17	420
	01 B 150M	M8x30	6	35	M8x30	6	26	-	-	-	M6x10	3	7.8	M20x100	17	420	M20x100	17	420
	02 B 150M	M8x30	6	35	M8x30	6	26	-	-	-	M6x10	3	7.8	M20x100	17	420	M24x100	19	712
	03 B 150M	M10x45	8	70	M10x45	8	52.5	M10x30	8	35	M10x16	5	30	M20x100	17	420	-	-	-
155	01 B 155M	M8x30	6	35	M8x30	6	26	-	-	-	M6x10	3	7.8	M20x100	17	420	M20x100	17	420
	02 B 155M	M8x30	6	35	M8x30	6	26	-	-	-	M6x10	3	7.8	M20x100	17	420	M24x100	19	712

Shaft Diameter d (mm)	Bearing reference	Clamping ring screw (1)			Cartridge joint screw (1)			Cartridge radial screw (1)			Side screw (1)			Pedestal joint screw (1)			Flange joint screw (1)		
		Screw size	Key size A/F (mm)	Torque (2) (Nm)	Screw size	Key size A/F (mm)	Torque (Nm)	Screw size	Key size A/F (mm)	Torque (Nm)	Screw size	Key size A/F (mm)	Torque (Nm)	Screw size	Key size A/F (mm)	Torque (Nm)	Screw size	Key size A/F (mm)	Torque (Nm)
160	01 B 600-160M	M8x30	6	35	M8x30	6	26	-	-	-	M6x10	3	7.8	M20x100	17	420	M20x100	17	420
	01 B 160M	M8x30	6	35	M8x30	6	26	-	-	-	M6x10	3	7.8	M16x65	14	225	M20x100	17	420
	02 B 600-160M	M8x30	6	35	M8x30	6	26	-	-	-	M6x10	3	7.8	M20x100	17	420	M24x100	19	712
	02 B 160M	M10x45	8	70	M10x45	8	52.5	-	-	-	M6x10	3	7.8	M20x100	17	420	M24x120	19	712
	03 B 160M	M12x55	10	120	M12x55	10	90	M12x35	10	60	M10x16	5	30	M20x100	17	420	-	-	-
170	01 B 608-170M	M8x30	6	35	M8x30	6	26	-	-	-	M6x10	3	7.8	M16x65	14	225	M20x100	17	420
	01 B 170M	M8x30	6	35	M8x30	6	26	-	-	-	M6x10	3	7.8	M16x65	14	225	M20x100	17	420
	02 B 170M	M10x45	8	70	M10x45	8	52.5	-	-	-	M6x10	3	7.8	M20x100	17	420	M24x120	19	712
	03 B 170M	M12x55	10	120	M12x55	10	90	M12x35	10	60	M10x16	5	30	M20x100	17	420	-	-	-
175	01 B 175M	M8x30	6	35	M8x30	6	26	-	-	-	M6x10	3	7.8	M16x65	14	225	M20x100	17	420
	02 B 175M	M10x45	8	70	M10x45	8	52.5	M10x25	8	35	M6x10	3	7.8	M20x100	17	420	M24x120	19	712
180	01 B 180M	M8x30	6	35	M8x30	6	26	-	-	-	M6x10	3	7.8	M16x65	14	225	M20x100	17	420
	02 B 180M	M10x45	8	70	M10x45	8	52.5	M10x25	8	35	M6x10	3	7.8	M20x100	17	420	M24x120	19	712
	03 B 180M	M12x55	10	120	M12x55	10	90	M12x35	10	60	M10x16	5	30	M20x100	17	420	-	-	-
190	01 B 190M	M8x30	6	35	M8x30	6	26	M10x20	8	35	M6x10	3	7.8	M16x65	14	225	M24x100	19	712
	02 B 190M	M12x55	10	120	M12x55	10	90	M10x30	8	35	M6x10	3	7.8	M20x100	17	420	M24x120	19	712
	03 B 190M	M12x55	10	120	M12x55	10	90	M12x40	10	60	M10x16	5	30	M24x100	19	712	-	-	-
200	01 B 200M	M8x30	6	35	M8x30	6	26	M10x20	8	35	M6x10	3	7.8	M16x65	14	225	M24x100	19	712
	02 B 200M	M12x55	10	120	M12x55	10	90	M10x30	8	35	M6x10	3	7.8	M20x100	17	420	M24x120	19	712
	03 B 200M	M12x55	10	120	M12x55	10	90	M12x40	10	60	M10x16	5	30	M24x100	19	712	-	-	-
220	01 B 220M	M10x45	8	70	M10x45	8	52.5	M10x20	8	35	M6x10	3	7.8	M16x65	14	225	M24x100	19	712
	02 B 220M	M12x55	10	120	M12x55	10	90	M10x30	8	35	M6x10	3	7.8	M20x100	17	420	M24x120	19	712
	03 B 220M	M16x65	14	300	M16x75	14	225	M12x40	10	60	M10x16	5	30	M20x100	17	420	-	-	-
230	01 B 230M	M10x45	8	70	M10x45	8	52.5	M10x20	8	35	M6x10	3	7.8	M16x65	14	225	M24x100	19	712
	02 B 230M	M12x55	10	120	M12x55	10	90	M10x30	8	35	M6x10	3	7.8	M20x100	17	420	M24x120	19	712
240	01 B 240M	M10x45	8	70	M10x45	8	52.5	M10x20	8	35	M6x10	3	7.8	M20x80	17	420	M24x100	19	712
	02 B 240M	M12x55	10	120	M12x55	10	90	M10x30	8	35	M10x16	5	30	M20x100	17	420	M24x100	19	712
	03 B 240M	M16x65	14	300	M16x75	14	225	M12x40	10	60	M10x16	5	30	M20x100	17	420	-	-	-
250	01 B 250M	M10x45	8	70	M10x45	8	52.5	M10x20	8	35	M6x10	3	7.8	M20x80	17	420	M24x100	19	712
	02 B 250M	M12x55	10	120	M12x55	10	90	M10x30	8	35	M10x16	5	30	M20x100	17	420	M24x100	19	712
	03 B 250M	M16x65	14	300	M16x75	14	225	M12x40	10	60	M10x16	5	30	M20x100	17	420	-	-	-

(1) All screws are metric coarse thread, grade 12.9

(2) For vertical shaft or high thrust applications the clamping ring screw torque should be increased by up to 20%

INSTALLATION AND ASSEMBLY

SCREW SIZES, WRENCH SIZES AND TORQUES

Shaft Diameter (mm)	Bearing reference	Clamping ring screw (1)			Cartridge joint screw (1)			Cartridge radial screw (1)			Side screw (1)			Pedestal joint screw (1)			Flange joint screw (1)		
		Screw size	Key size A/F (mm)	Torque (2) (Nm)	Screw size	Key size A/F (mm)	Torque (Nm)	Screw size	Key size A/F (mm)	Torque (Nm)	Screw size	Key size A/F (mm)	Torque (Nm)	Screw size	Key size A/F (mm)	Torque (Nm)	Screw size	Key size A/F (mm)	Torque (Nm)
260	01 B 1000-260M	M10x45	8	70	M10x45	8	52.5	M10x20	8	35	M6x10	3	7.8	M20x80	17	420	M24x100	19	712
	01 B 260M	M10x45	8	70	M10x45	8	52.5	M10x25	8	35	M10x16	5	30	M20x100	17	420	M24x120	19	712
	02 B 260M	M12x55	10	120	M12x55	10	90	M10x30	8	35	M10x16	5	30	M20x100	17	420	M24x100	19	712
	03 B 260M	M16x65	14	300	M16x75	14	225	M12x40	10	60	M10x16	5	30	M20x100	17	420	-	-	-
270	01 B 270M	M10x45	8	70	M10x45	8	52.5	M10x25	8	35	M10x16	5	30	M20x100	17	420	M24x120	19	712
275	01 B 275M	M10x45	8	70	M10x45	8	52.5	M10x25	8	35	M10x16	5	30	M20x100	17	420	M24x120	19	712
280	01 B 280M	M10x45	8	70	M10x45	8	52.5	M10x25	8	35	M10x16	5	30	M20x100	17	420	M24x120	19	712
	02 B 280M	M16x65	14	300	M16x75	14	225	M10x30	8	35	M10x16	5	30	M20x100	17	420	M24x100	19	712
	03X B 280M	M20x80	17	560	M20x100	17	420	M12x40	10	60	M10x16	5	30	M20x100	17	420	-	-	-
	03E B 280M	M20x80	17	560	M20x100	17	420	M12x35	10	60	M10x16	5	30	M20x100	17	420	-	-	-
290	01 B 290M	M10x45	8	70	M10x45	8	52.5	M10x25	8	35	M10x16	5	30	M20x100	17	420	M24x120	19	712
	03 B 290M	M20x80	17	560	M20x100	17	420	M12x55	10	60	M10x16	5	30	M20x100	17	420	-	-	-
300	01 B 300M	M10x45	8	70	M10x45	8	52.5	M10x25	8	35	M10x16	5	30	M20x100	17	420	M24x120	19	712
	02 B 300M	M16x65	14	300	M16x75	14	225	M10x30	8	35	M10x16	5	30	M20x100	17	420	M24x100	19	712
	03 B 300M	M20x80	17	560	M20x100	17	420	M12x55	10	60	M10x16	5	30	M20x100	17	420	-	-	-
320	01 B 320M	M12x55	10	120	M12x55	10	90	M10x25	8	35	M10x16	5	30	M20x100	17	420	M24x120	19	712
	02 B 320M	M16x65	14	300	M16x75	14	225	M10x30	8	35	M10x16	5	30	M20x100	17	420	M24x120	19	712
	03 B 320M	M20x80	17	560	M20x100	17	420	M12x55	10	60	M10x16	5	30	M24x120	19	712	-	-	-
330	01 B 330M	M12x55	10	120	M12x55	10	90	M10x25	8	35	M10x16	5	30	M20x100	17	420	M24x120	19	712
	02 B 330M	M16x65	14	300	M16x75	14	225	M10x30	8	35	M10x16	5	30	M20x100	17	420	M24x120	19	712
340	01 B 1300-340M	M12x55	10	120	M12x55	10	90	M10x25	8	35	M10x16	5	30	M20x100	17	420	M24x120	19	712
	01 B 340M	M12x55	10	120	M12x55	10	90	M10x25	8	35	M10x16	5	30	M20x100	17	420	M24x120	19	712
	02 B 340M	M16x65	14	300	M16x75	14	225	M12x30	10	60	M10x16	5	30	M20x100	17	420	-	-	-
	03E B 340M	M24x100	19	950	M20x100	17	420	M12x40	10	60	M16x25	8	125	M24x100	19	712	-	-	-
350	01 B 350M	M12x55	10	120	M12x55	10	90	M10x25	8	35	M10x16	5	30	M20x100	17	420	M24x120	19	712
	02 B 350M	M16x65	14	300	M16x75	14	225	M12x30	10	60	M10x16	5	30	M20x100	17	420	-	-	-
360	01 B 1400-360M	M12x55	10	120	M12x55	10	90	M10x25	8	35	M10x16	5	30	M20x100	17	420	M24x120	19	712
	01 B 360M	M12x55	10	120	M12x55	10	90	M10x25	8	35	M10x16	5	30	M20x100	17	420	M24x100	19	712
	02 B 360M	M16x65	14	300	M16x75	14	225	M12x30	10	60	M10x16	5	30	M20x100	17	420	-	-	-
	03E B 360M	M24x100	19	950	M20x100	17	420	M12x40	10	60	M16x25	8	125	M24x100	19	712	-	-	-
	03X B 360M	M24x100	19	950	M20x100	17	420	M12x55	10	60	M10x16	5	30	M24x120	19	712	-	-	-

INSTALLATION AND ASSEMBLY

SCREW SIZES, WRENCH SIZES AND TORQUES

Shaft Diameter d (mm)	Bearing reference	Clamping ring screw (1)			Cartridge joint screw (1)			Cartridge radial screw (1)			Side screw (1)			Pedestal joint screw (1)			Flange joint screw (1)		
		Screw size	Key size A/F (mm)	Torque (2) (Nm)	Screw size	Key size A/F (mm)	Torque (Nm)	Screw size	Key size A/F (mm)	Torque (Nm)	Screw size	Key size A/F (mm)	Torque (Nm)	Screw size	Key size A/F (mm)	Torque (Nm)	Screw size	Key size A/F (mm)	Torque (Nm)
380	01 B 380M	M12x55	10	120	M12x55	10	90	M10x25	8	35	M10x16	5	30	M20x100	17	420	M24x100	19	712
	02 B 380M	M16x65	14	300	M16x75	14	225	M12x30	10	60	M10x16	5	30	M20x100	17	420	-	-	-
	03 B 380M	M24x100	19	950	M20x100	17	420	M12x55	10	60	M10x16	5	30	M24x120	19	712	-	-	-
390	01 B 390M	M12x55	10	120	M12x55	10	90	M10x25	8	35	M10x16	5	30	M20x100	17	420	M24x100	19	712
400	01 B 400M	M12x55	10	120	M12x55	10	90	M10x25	8	35	M10x16	5	30	M20x100	17	420	M24x100	19	712
	02 B 400M	M16x65	14	300	M16x75	14	225	M12x35	10	60	M10x16	5	30	M20x100	17	420	-	-	-
	03 B 400M	M24x100	19	950	M20x100	17	420	M12x55	10	60	M10x16	5	30	M24x120	19	712	-	-	-
420	01 B 420M	M12x55	10	120	M12x55	10	90	M12x25	10	60	M10x16	5	30	M20x80	17	420	-	-	-
	02 B 420M	M16x65	14	300	M16x75	14	225	M12x35	10	60	M10x16	5	30	M20x100	17	420	-	-	-
	03E B 420M	M24x100	19	950	M20x100	17	420	M12x40	10	60	M16x25	8	125	M24x120	19	712	-	-	-
440	01 B 440M	M12x55	10	120	M12x55	10	90	M12x25	10	60	M10x16	5	30	M20x80	17	420	-	-	-
	02 B 440M	M16x65	14	300	M16x75	14	225	M12x35	10	60	M10x16	5	30	M20x100	17	420	-	-	-
	03E B 440M	M24x100	19	950	M20x100	17	420	M12x40	10	60	M16x25	8	125	M24x120	19	712	-	-	-
460	01 B 460M	M12x55	10	120	M12x55	10	90	M12x25	10	60	M10x16	5	30	M20x80	17	420	-	-	-
	02 B 460M	M16x65	14	300	M16x75	14	225	M12x35	10	60	M10x16	5	30	M20x100	17	420	-	-	-
	03E B 460M	M24x100	19	950	M20x100	17	420	M12x55	10	60	M16x25	8	125	M24x120	19	712	-	-	-
	03X B 460M	M24x100	19	950	M20x100	17	420	M16x65	14	150	M10x16	5	30	M24x120	19	712	-	-	-
480	01 B 480M	M12x55	10	120	M12x55	10	90	M12x25	10	60	M10x16	5	30	M20x100	17	420	-	-	-
	02 B 480M	M20x80	17	560	M20x100	17	420	M12x35	10	60	M10x16	5	30	M24x120	19	712	-	-	-
	03X B 480M	M24x100	19	950	M20x100	17	420	M16x65	14	150	M10x16	5	30	M24x120	19	712	-	-	-
500	01 B 500M	M16x65	14	300	M16x75	14	225	M12x30	10	60	M10x16	5	30	M20x100	17	420	-	-	-
	02 B 500M	M20x80	17	560	M20x100	17	420	M12x35	10	60	M10x16	5	30	M24x120	19	712	-	-	-
	03 B 500M	M24x100	19	950	M20x100	17	420	M16x65	14	150	M10x16	5	30	M24x120	19	712	-	-	-
530	01 B 530M	M16x65	14	300	M16x75	14	225	M12x30	10	60	M10x16	5	30	M20x100	17	420	-	-	-
	02 B 530M	M20x80	17	560	M20x100	17	420	M12x35	10	60	M10x16	5	30	M24x120	19	712	-	-	-
	03 B 530M	M24x100	19	950	M20x100	17	420	M16x65	14	150	M10x16	5	30	M24x120	19	712	-	-	-
560	01 B 560M	M16x65	14	300	M16x75	14	225	M12x30	10	60	M10x16	5	30	M20x100	17	420	-	-	-
	02 B 560M	M20x80	17	560	M20x100	17	420	M12x35	10	60	M10x16	5	30	M24x120	19	712	-	-	-
	03E B 560M	M24x100	19	950	M20x100	17	420	M12x55	10	60	M16x25	8	125	M24x120	19	712	-	-	-
580	01 B 580M	M16x65	14	300	M16x75	14	225	M12x30	10	60	M10x16	5	30	M20x100	17	420	-	-	-
	02 B 580M	M20x80	17	560	M20x100	17	420	M12x35	10	60	M10x16	5	30	M24x120	19	712	-	-	-
600	01 B 600M	M16x65	14	300	M16x75	14	225	M12x30	10	60	M10x16	5	30	M20x100	17	420	-	-	-
	02 B 600M	M20x80	17	560	M20x100	17	420	M12x35	10	60	M10x16	5	30	M24x120	19	712	-	-	-
	03E B 600M	M24x100	19	950	M20x100	17	420	M12x55	10	60	M16x25	8	125	M24x120	19	712	-	-	-

(1) All screws are metric coarse thread, grade 12.9

(2) For vertical shaft or high thrust applications the clamping ring screw torque should be increased by up to 20%

GREASE QUANTITIES FOR INITIAL LUBRICATION

The quantity of grease required on initial assembly is dependent upon operating speed and temperature.

If the operating temperature is below 80°C the quantity of grease may be determined directly according to bearing reference and operating speed from the following table.

If the operating temperature is above 80°C, a 25% pack of

grease should be used regardless of speed (refer to the right hand column of the table).

With a 'full pack' of grease the space within the cartridge (i.e. surrounding the bearing components) in the assembled unit is completely filled with grease.

The table assumes normal density grease (about 0.85g/cm³).

Shaft Diameter d (mm)	Bearing Reference	Speed (rpm) up to	Grease (full pack) (kg)	Speed (rpm)		Grease (75% full pack) (kg)	Speed (rpm)		Grease (50% full pack) (kg)	Speed (rpm)		Grease (33% full pack) (kg)	Speed (rpm) over	Grease (25% full pack) (kg)
				from	to		from	to		from	to			
35	01 B 35M	1312	0.06	1312	2625	0.05	2625	3937	0.03	3937	5249	0.02	5249	0.02
40	01 B 40M	1312	0.06	1312	2625	0.05	2625	3937	0.03	3937	5249	0.02	5249	0.02
45	01E B 45M	984	0.09	984	1969	0.07	1969	2953	0.05	2953	3937	0.03	3937	0.02
50	01E B 50M	984	0.09	984	1969	0.07	1969	2953	0.05	2953	3937	0.03	3937	0.02
	02 B 50M	984	0.15	984	1969	0.11	1969	2953	0.08	2953	3937	0.05	3937	0.04
55	01E B 55M	787	0.15	787	1575	0.11	1575	2362	0.08	2362	3150	0.05	3150	0.04
60	01E B 60M	787	0.15	787	1575	0.11	1575	2362	0.08	2362	3150	0.05	3150	0.04
	02 B 60M	787	0.21	787	1575	0.16	1575	2362	0.11	2362	3150	0.07	3150	0.05
65	01E B 65M	787	0.15	787	1575	0.11	1575	2362	0.08	2362	3150	0.05	3150	0.04
	02 B 65M	787	0.21	787	1575	0.16	1575	2362	0.11	2362	3150	0.07	3150	0.05
70	01E B 70M	656	0.18	656	1312	0.14	1312	1969	0.09	1969	2625	0.06	2625	0.05
	02 B 70M	656	0.30	656	1312	0.23	1312	1969	0.15	1969	2625	0.10	2625	0.08
75	100 B 75M	656	0.15	656	1312	0.11	1312	1969	0.08	1969	2625	0.05	2625	0.04
	01E B 75M	656	0.18	656	1312	0.14	1312	1969	0.09	1969	2625	0.06	2625	0.05
	02 B 75M	656	0.30	656	1312	0.23	1312	1969	0.15	1969	2625	0.10	2625	0.08
80	01E B 80M	562	0.30	562	1125	0.23	1125	1687	0.15	1687	2250	0.10	2250	0.08
	02 B 80M	562	0.45	562	1125	0.34	1125	1687	0.23	1687	2250	0.15	2250	0.11
85	100 B 85M	573	0.22	573	1145	0.17	1145	1718	0.11	1718	2291	0.07	2291	0.06
	01E B 85M	562	0.30	562	1125	0.23	1125	1687	0.15	1687	2250	0.10	2250	0.08
	02 B 85M	562	0.45	562	1125	0.34	1125	1687	0.23	1687	2250	0.15	2250	0.11
90	01E B 90M	562	0.30	562	1125	0.23	1125	1687	0.15	1687	2250	0.10	2250	0.08
	02 B 90M	562	0.45	562	1125	0.34	1125	1687	0.23	1687	2250	0.15	2250	0.11

Shaft Diameter (mm)	Bearing Reference	Speed (rpm) up to	Grease (full pack) (kg)	Speed (rpm)		Grease (75% full pack) (kg)	Speed (rpm)		Grease (50% full pack) (kg)	Speed (rpm)		Grease (33% full pack) (kg)	Speed (rpm) over	Grease (25% full pack) (kg)
				from	to		from	to		from	to			
95	01E B 95M	492	0.36	492	984	0.27	984	1476	0.18	1476	1969	0.12	1969	0.09
100	100 B 100M	492	0.36	492	984	0.27	984	1476	0.18	1476	1969	0.12	1969	0.09
	01E B 100M	492	0.36	492	984	0.27	984	1476	0.18	1476	1969	0.12	1969	0.09
	02 B 100M	492	0.60	492	984	0.45	984	1476	0.30	1476	1969	0.20	1969	0.15
	03 B 100M	492	1.20	492	984	0.90	984	1476	0.60	1476	1969	0.40	1969	0.30
105	01E B 105M	492	0.36	492	984	0.27	984	1476	0.18	1476	1969	0.12	1969	0.09
	02 B 105M	492	0.60	492	984	0.45	984	1476	0.30	1476	1969	0.20	1969	0.15
110	100 B 110M	437	0.36	437	875	0.27	875	1312	0.18	1312	1750	0.12	1750	0.09
	01 B 110M	437	0.51	437	875	0.38	875	1312	0.26	1312	1750	0.17	1750	0.13
	02 B 110M	437	0.90	437	875	0.68	875	1312	0.45	1312	1750	0.30	1750	0.23
	03 B 110M	437	1.40	437	875	1.05	875	1312	0.70	1312	1750	0.46	1750	0.35
115	01 B 115M	437	0.51	437	875	0.38	875	1312	0.26	1312	1750	0.17	1750	0.13
	02 B 115M	437	0.90	437	875	0.68	875	1312	0.45	1312	1750	0.30	1750	0.23
120	100 B 120M	394	0.49	394	787	0.37	787	1181	0.25	1181	1575	0.16	1575	0.12
	01 B 120M	394	0.60	394	787	0.45	787	1181	0.30	1181	1575	0.20	1575	0.15
	02 B 120M	394	1.20	394	787	0.90	787	1181	0.60	1181	1575	0.40	1575	0.30
	03 B 120M	437	1.40	437	875	1.05	875	1312	0.70	1312	1750	0.46	1750	0.35
125	01 B 125M	394	0.60	394	787	0.45	787	1181	0.30	1181	1575	0.20	1575	0.15
	02 B 125M	394	1.20	394	787	0.90	787	1181	0.60	1181	1575	0.40	1575	0.30
130	100 B 130M	394	0.49	394	787	0.37	787	1181	0.25	1181	1575	0.16	1575	0.12
	01 B 130M	394	0.60	394	787	0.45	787	1181	0.30	1181	1575	0.20	1575	0.15
	02 B 130M	394	1.20	394	787	0.90	787	1181	0.60	1181	1575	0.40	1575	0.30
	03 B 130M	394	1.40	394	787	1.05	787	1181	0.70	1181	1575	0.46	1575	0.35
135	01 B 135M	358	0.78	358	716	0.59	716	1074	0.39	1074	1432	0.26	1432	0.20
140	100 B 140M	358	0.64	358	716	0.48	716	1074	0.32	1074	1432	0.21	1432	0.16
	01 B 140M	358	0.78	358	716	0.59	716	1074	0.39	1074	1432	0.26	1432	0.20
	02 B 140M	358	1.40	358	716	1.05	716	1074	0.70	1074	1432	0.46	1432	0.35
	03 B 140M	358	2.00	358	716	1.50	716	1074	1.00	1074	1432	0.66	1432	0.50
145	02 B 145M	358	1.40	358	716	1.05	716	1074	0.70	1074	1432	0.46	1432	0.35

INSTALLATION AND ASSEMBLY

GREASE QUANTITIES FOR INITIAL LUBRICATION

Shaft Diameter d (mm)	Bearing Reference	Speed (rpm) up to	Grease (full pack) (kg)	Speed (rpm)		Grease (75% full pack) (kg)	Speed (rpm)		Grease (50% full pack) (kg)	Speed (rpm)		Grease (33% full pack) (kg)	Speed (rpm) over	Grease (25% full pack) (kg)
				from	to		from	to		from	to			
150	100 B 150M	328	1.02	328	656	0.77	656	984	0.51	984	1312	0.34	1312	0.26
	01 B 150M	328	0.90	328	656	0.68	656	984	0.45	984	1312	0.30	1312	0.23
	02 B 150M	328	1.40	328	656	1.05	656	984	0.70	984	1312	0.46	1312	0.35
	03 B 150M	328	2.70	328	656	2.03	656	984	1.35	984	1312	0.89	1312	0.68
155	01 B 155M	328	0.90	328	656	0.68	656	984	0.45	984	1312	0.30	1312	0.23
	02 B 155M	328	1.40	328	656	1.05	656	984	0.70	984	1312	0.46	1312	0.35
160	01 B 600-160M	328	0.90	328	656	0.68	656	984	0.45	984	1312	0.30	1312	0.23
	01 B 160M	303	1.00	303	606	0.75	606	909	0.50	909	1211	0.33	1211	0.25
	02 B 600-160M	328	1.40	328	656	1.05	656	984	0.70	984	1312	0.46	1312	0.35
	02 B 160M	303	1.40	303	606	1.05	606	909	0.70	909	1211	0.46	1211	0.35
	03 B 160M	303	3.60	303	606	2.70	606	909	1.80	909	1211	1.19	1211	0.90
170	01 B 608-170M	303	1.00	303	606	0.75	606	909	0.50	909	1211	0.33	1211	0.25
	01 B 170M	281	1.20	281	562	0.90	562	844	0.60	844	1125	0.40	1125	0.30
	02 B 170M	303	2.00	303	606	1.50	606	909	1.00	909	1211	0.66	1211	0.50
	03 B 170M	303	3.60	303	606	2.70	606	909	1.80	909	1211	1.19	1211	0.90
175	01 B 175M	281	1.20	281	562	0.90	562	844	0.60	844	1125	0.40	1125	0.30
	02 B 175M	281	2.00	281	562	1.50	562	844	1.00	844	1125	0.66	1125	0.50
180	01 B 180M	281	1.20	281	562	0.90	562	844	0.60	844	1125	0.40	1125	0.30
	02 B 180M	281	2.00	281	562	1.50	562	844	1.00	844	1125	0.66	1125	0.50
	03 B 180M	281	4.20	281	562	3.15	562	844	2.10	844	1125	1.39	1125	1.05
190	01 B 190M	246	1.40	246	492	1.05	492	738	0.70	738	984	0.46	984	0.35
	02 B 190M	246	2.70	246	492	2.03	492	738	1.35	738	984	0.89	984	0.68
	03 B 190M	246	5.40	246	492	4.05	492	738	2.70	738	984	1.78	984	1.35
200	01 B 200M	246	1.40	246	492	1.05	492	738	0.70	738	984	0.46	984	0.35
	02 B 200M	246	2.70	246	492	2.03	492	738	1.35	738	984	0.89	984	0.68
	03 B 200M	246	5.40	246	492	4.05	492	738	2.70	738	984	1.78	984	1.35
220	01 B 220M	219	1.40	219	437	1.05	437	656	0.70	656	875	0.46	875	0.35
	02 B 220M	219	3.60	219	437	2.70	437	656	1.80	656	875	1.19	875	0.90
	03 B 220M	219	6.90	219	437	5.18	437	656	3.45	656	875	2.28	875	1.73
230	01 B 230M	219	1.40	219	437	1.05	437	656	0.70	656	875	0.46	875	0.35
	02 B 230M	219	3.60	219	437	2.70	437	656	1.80	656	875	1.19	875	0.90

Shaft Diameter d (mm)	Bearing Reference	Speed (rpm) up to	Grease (full pack) (kg)	Speed (rpm)		Grease (75% full pack) (kg)	Speed (rpm)		Grease (50% full pack) (kg)	Speed (rpm)		Grease (33% full pack) (kg)	Speed (rpm) over	Grease (25% full pack) (kg)
				from	to		from	to		from	to			
240	01 B 240M	197	2.00	197	394	1.50	394	591	1.00	591	787	0.66	787	0.50
	02 B 240M	197	4.20	197	394	3.15	394	591	2.10	591	787	1.39	787	1.05
	03 B 240M	197	8.10	197	394	6.08	394	591	4.05	591	787	2.67	787	2.03
250	01 B 250M	197	2.00	197	394	1.50	394	591	1.00	591	787	0.66	787	0.50
	02 B 250M	197	4.20	197	394	3.15	394	591	2.10	591	787	1.39	787	1.05
	03 B 250M	197	8.10	197	394	6.08	394	591	4.05	591	787	2.67	787	2.03
260	01 B 1000-260M	197	2.00	197	394	1.50	394	591	1.00	591	787	0.66	787	0.50
	01 B 260M	179	2.00	179	358	1.50	358	537	1.00	537	716	0.66	716	0.50
	02 B 260M	197	4.20	197	394	3.15	394	591	2.10	591	787	1.39	787	1.05
	03 B 260M	197	8.10	197	394	6.08	394	591	4.05	591	787	2.67	787	2.03
270	01 B 270M	179	2.00	179	358	1.50	358	537	1.00	537	716	0.66	716	0.50
275	01 B 275M	179	2.00	179	358	1.50	358	537	1.00	537	716	0.66	716	0.50
280	01 B 280M	179	2.00	179	358	1.50	358	537	1.00	537	716	0.66	716	0.50
	02 B 280M	179	4.80	179	358	3.60	358	537	2.40	537	716	1.58	716	1.20
	03X B 280M	179	10.00	179	358	7.50	358	537	5.00	537	716	3.30	716	2.50
	03E B 280M	179	10.00	179	358	7.50	358	537	5.00	537	716	3.30	716	2.50
290	01 B 290M	164	2.00	164	328	1.50	328	492	1.00	492	656	0.66	656	0.50
	03 B 290M	164	11.00	164	328	8.25	328	492	5.50	492	656	3.63	656	2.75
300	01 B 300M	164	2.00	164	328	1.50	328	492	1.00	492	656	0.66	656	0.50
	02 B 300M	164	5.40	164	328	4.05	328	492	2.70	492	656	1.78	656	1.35
	03 B 300M	164	11.00	164	328	8.25	328	492	5.50	492	656	3.63	656	2.75
320	01 B 320M	151	2.76	151	303	2.07	303	454	1.38	454	606	0.91	606	0.69
	02 B 320M	151	6.60	151	303	4.95	303	454	3.30	454	606	2.18	606	1.65
	03 B 320M	151	12.00	151	303	9.00	303	454	6.00	454	606	3.96	606	3.00
330	01 B 330M	151	2.76	151	303	2.07	303	454	1.38	454	606	0.91	606	0.69
	02 B 330M	151	6.60	151	303	4.95	303	454	3.30	454	606	2.18	606	1.65
340	01 B 1300-340M	151	2.76	151	303	2.07	303	454	1.38	454	606	0.91	606	0.69
	01 B 340M	141	3.00	141	281	2.25	281	422	1.50	422	562	0.99	562	0.75
	02 B 340M	141	7.20	141	281	5.40	281	422	3.60	422	562	2.38	562	1.80
	03E B 340M	141	15.00	141	281	11.25	281	422	7.50	422	562	4.95	562	3.75

INSTALLATION AND ASSEMBLY

GREASE QUANTITIES FOR INITIAL LUBRICATION

Shaft Diameter d (mm)	Bearing Reference	Speed (rpm) up to	Grease (full pack) (kg)	Speed (rpm)		Grease (75% full pack) (kg)	Speed (rpm)		Grease (50% full pack) (kg)	Speed (rpm)		Grease (33% full pack) (kg)	Speed (rpm) over	Grease (25% full pack) (kg)
				from	to		from	to		from	to			
350	01 B 350M	141	3.00	141	281	2.25	281	422	1.50	422	562	0.99	562	0.75
	02 B 350M	141	7.20	141	281	5.40	281	422	3.60	422	562	2.38	562	1.80
360	01 B 1400-360M	141	3.00	141	281	2.25	281	422	1.50	422	562	0.99	562	0.75
	01 B 360M	131	3.00	131	262	2.25	262	394	1.50	394	525	0.99	525	0.75
	02 B 360M	141	7.20	141	281	5.40	281	422	3.60	422	562	2.38	562	1.80
	03E B 360M	141	15.00	141	281	11.25	281	422	7.50	422	562	4.95	562	3.75
	03X B 360M	141	15.00	141	281	11.25	281	422	7.50	422	562	4.95	562	3.75
380	01 B 380M	131	3.00	131	262	2.25	262	394	1.50	394	525	0.99	525	0.75
	02 B 380M	131	7.80	131	262	5.85	262	394	3.90	394	525	2.57	525	1.95
	03 B 380M	131	16.20	131	262	12.15	262	394	8.10	394	525	5.35	525	4.05
390	01 B 390M	123	3.60	123	246	2.70	246	369	1.80	369	492	1.19	492	0.90
400	01 B 400M	123	3.60	123	246	2.70	246	369	1.80	369	492	1.19	492	0.90
	02 B 400M	123	9.00	123	246	6.75	246	369	4.50	369	492	2.97	492	2.25
	03 B 400M	131	16.20	131	262	12.15	262	394	8.10	394	525	5.35	525	4.05
420	01 B 420M	116	4.20	116	232	3.15	232	347	2.10	347	463	1.39	463	1.05
	02 B 420M	116	9.60	116	232	7.20	232	347	4.80	347	463	3.17	463	2.40
	03E B 420M	116	21.60	116	232	16.20	232	347	10.80	347	463	7.13	463	5.40
440	01 B 440M	109	4.20	109	219	3.15	219	328	2.10	328	437	1.39	437	1.05
	02 B 440M	109	9.60	109	219	7.20	219	328	4.80	328	437	3.17	437	2.40
	03E B 440M	116	21.60	116	232	16.20	232	347	10.80	347	463	7.13	463	5.40
460	01 B 460M	109	4.20	109	219	3.15	219	328	2.10	328	437	1.39	437	1.05
	02 B 460M	109	9.60	109	219	7.20	219	328	4.80	328	437	3.17	437	2.40
	03E B 460M	109	24.60	109	219	18.45	219	328	12.30	328	437	8.12	437	6.15
	03X B 460M	104	24.60	104	207	18.45	207	311	12.30	311	414	8.12	414	6.15
480	01 B 480M	104	4.80	104	207	3.60	207	311	2.40	311	414	1.58	414	1.20
	02 B 480M	104	10.20	104	207	7.65	207	311	5.10	311	414	3.37	414	2.55
	03X B 480M	109	24.60	109	219	18.45	219	328	12.30	328	437	8.12	437	6.15
500	01 B 500M	98	4.80	98	197	3.60	197	295	2.40	295	394	1.58	394	1.20
	02 B 500M	98	10.80	98	197	8.10	197	295	5.40	295	394	3.56	394	2.70
	03 B 500M	98	30.00	98	197	22.50	197	295	15.00	295	394	9.90	394	7.50

INSTALLATION AND ASSEMBLY

GREASE QUANTITIES FOR INITIAL LUBRICATION

Shaft Diameter (mm)	Bearing Reference	Speed (rpm) up to	Grease (full pack) (kg)	Speed (rpm)		Grease (75% full pack) (kg)	Speed (rpm)		Grease (50% full pack) (kg)	Speed (rpm)		Grease (33% full pack) (kg)	Speed (rpm) over	Grease (25% full pack) (kg)
				from	to		from	to		from	to			
530	01 B 530M	94	5.40	94	187	4.05	187	281	2.70	281	375	1.78	375	1.35
	02 B 530M	94	11.40	94	187	8.55	187	281	5.70	281	375	3.76	375	2.85
	03 B 530M	98	30.00	98	197	22.50	197	295	15.00	295	394	9.90	394	7.50
560	01 B 560M	89	5.40	89	179	4.05	179	268	2.70	268	358	1.78	358	1.35
	02 B 560M	89	11.40	89	179	8.55	179	268	5.70	268	358	3.76	358	2.85
	03E B 560M	89	36.00	89	179	27.00	179	268	18.00	268	358	11.88	358	9.00
580	01 B 580M	86	6.00	86	171	4.50	171	257	3.00	257	342	1.98	342	1.50
	02 B 580M	86	12.60	86	171	9.45	171	257	6.30	257	342	4.16	342	3.15
600	01 B 600M	82	6.00	82	164	4.50	164	246	3.00	246	328	1.98	328	1.50
	02 B 600M	82	12.60	82	164	9.45	164	246	6.30	246	328	4.16	328	3.15
	03E B 600M	86	38.40	86	171	28.80	171	257	19.20	257	342	12.67	342	9.60

Routine greasing frequency depends on temperature, speed and environment. Grease quantities depend on bearing size. Excessive quantities of lubricant should not be used. Particularly at high speeds, this may result in excessive churning and overheating.

Automatic lubrication systems should be metered to deliver grease at an average rate equivalent to the routine greasing periods and quantities specified.

If it can be done safely, routine greasing should occur while the shaft is rotating to help distribute the grease. Do not mix different types of grease in the bearing.

The table below specifies routine greasing intervals. The shortest greasing interval should be selected to which one or more of the conditions in the table apply. If operating conditions fall outside those listed please contact our technical department for a recommended lubrication interval.

Routine greasing frequency	Operating conditions		
	Temperature	Speed dn (mm)	Environment (3)
100 hours	80°C to 175°C	200,000 to 300,000 (1)	very dirty/submerged
200 hours	60°C to 80°C	100,000 to 200,000	dusty/splashed
400 hours (2)	Below 60°C	up to 100,000	clean/dry

The following table specifies the required quantity of grease at each routine greasing. Note that 2ml is approximately one shot from a conventional side-lever grease gun. Smaller quantities may be delivered using a push-type gun.

Shaft Diam. d	Bearing Reference	Routine Grease Volume (ml)
35	01 B 35M	4
40	01 B 40M	4
45	01E B 45M	4
50	01E B 50M	4
	02 B 50M	4
55	01E B 55M	4
60	01E B 60M	4
	02 B 60M	4
65	01E B 65M	4
	02 B 65M	4
70	01E B 70M	4
	02 B 70M	4
75	100 B 75M	1*
	01E B 75M	4
	02 B 75M	4
80	01E B 80M	4
	02 B 80M	4
85	100 B 85M	1*
	01E B 85M	4
	02 B 85M	4
90	01E B 90M	4
	02 B 90M	4
95	01E B 95M	4
100	100 B 100M	2
	01E B 100M	4
	02 B 100M	4
	03 B 100M	4

Shaft Diam. d	Bearing Reference	Routine Grease Volume (ml)
105	01E B 105M	4
	02 B 105M	4
110	100 B 110M	2
	01 B 110M	4
	02 B 110M	4
115	03 B 110M	4
	01 B 115M	4
120	02 B 115M	4
	100 B 120M	4
125	01 B 120M	4
	02 B 120M	4
	03 B 120M	4
130	01 B 125M	4
	02 B 125M	4
135	100 B 130M	4
	01 B 130M	4
	02 B 130M	4
140	03 B 130M	4
	100 B 135M	4
145	100 B 140M	4
	01 B 140M	4
	02 B 140M	4
150	03 B 140M	8
	02 B 145M	4
155	100 B 150M	4
	01 B 150M	4
	02 B 150M	4
	03 B 150M	8

- (1) Up to bearing maximum in case of 100 Series bearings
- (2) For EX bearings and GR bearings used for location only (i.e. no nominal thrust load) this may be extended to 1000 hours. For applications where temperature and operating speed allow for a full pack of grease this may be extended to one year for EX bearings and GR bearings used for location only.
- (3) For applications where operating speed and temperature allow for a full pack of grease, regreasing can occur every 400 hours regardless of the working environment.

* May be increased to 2 if speed is less than 100,000dn (mm), or up to 200,000dn (mm) if operating temperature is less than 80°C.

ROUTINE GREASING

Shaft Diam. d	Bearing Reference	Routine Grease Volume (ml)
155	01 B 155M	4
	02 B 155M	4
160	01 B 600-160M	4
	01 B 160M	4
	02 B 600-160M	4
	02 B 160M	8
170	03 B 160M	8
	01 B 608-170M	4
	01 B 170M	4
175	02 B 170M	8
	03 B 170M	8
	01 B 175M	4
180	02 B 175M	8
	01 B 180M	4
	02 B 180M	8
190	03 B 180M	8
	01 B 190M	4
	02 B 190M	8
200	03 B 190M	16
	01 B 200M	4
	02 B 200M	8
220	03 B 200M	16
	01 B 220M	4
	02 B 220M	8
230	03 B 220M	16
	01 B 230M	4
	02 B 230M	8

Shaft Diam. d	Bearing Reference	Routine Grease Volume (ml)
240	01 B 240M	8
	02 B 240M	8
	03 B 240M	16
260	01 B 1000-260M	8
	01 B 260M	8
	02 B 260M	8
	03 B 260M	16
270	01 B 270M	8
275	01 B 275M	8
280	01 B 280M	8
	02 B 280M	16
	03X B 280M	16
	03E B 280M	16
290	01 B 290M	8
	03 B 290M	16
300	01 B 300M	8
	02 B 300M	16
	03 B 300M	16
320	01 B 320M	8
	02 B 320M	16
	03 B 320M	24
330	01 B 330M	8
	02 B 330M	16
340	01 B 1300-340M	8
	01 B 340M	8
	02 B 340M	16
	03E B 340M	24
350	01 B 350M	8
	02 B 350M	16

Shaft Diam. d	Bearing Reference	Routine Grease Volume (ml)
360	01 B 1400-360M	8
	01 B 360M	8
	02 B 360M	16
	03E B 360M	24
380	03X B 360M	24
	01 B 380M	8
	02 B 380M	16
390	03 B 380M	24
	01 B 390M	16
400	01 B 400M	16
	02 B 400M	16
	03 B 400M	24
420	01 B 420M	16
	02 B 420M	16
	03E B 420M	24
440	01 B 440M	16
	02 B 440M	24
	03E B 440M	32
460	01 B 460M	16
	02 B 460M	24
	03E B 460M	32
	03X B 460M	32
480	01 B 480M	16
	02 B 480M	24
	03X B 480M	32
500	01 B 500M	16
	02 B 500M	24
	03 B 500M	32

Shaft Diam. d	Bearing Reference	Routine Grease Volume (ml)
530	01 B 530M	16
	02 B 530M	24
	03 B 530M	32
560	01 B 560M	16
	02 B 560M	24
	03E B 560M	32
580	01 B 580M	16
	02 B 580M	24
600	01 B 600M	16
	02 B 600M	24
	03E B 600M	32

WHAT TO DO WITH YOUR USED BEARING

When a bearing reaches the end of its working life, it doesn't have to be discarded without providing further value. Three options for dealing with end-of-life bearings are outlined below.

Reconditioning

Cooper offer a reconditioning service for larger bearings. A used bearing is thoroughly cleaned and a detailed report prepared on its condition and the required work required to bring it back to an as-new functional condition. Generally a reconditioned bearing will consist of a combination of remachined components of the original bearing and new components to give the correct clearances.

Reconditioning is generally more economical than manufacture of new bearings, depending upon the amount of work required to the subject bearing, for the following bearings:

01 Series:	320mm/13" bore size and over
02 Series:	320mm/13" bore size and over
03 Series:	160mm/6½" bore size and over
04 Series:	all sizes
Thrust bearings:	all sizes

Cooper are also able to recondition radial and thrust cylindrical bearings of non-Cooper manufacture.

Failure Analysis

Cooper offer a failure analysis service for all sizes of bearing, of any age. Where appropriate, we will offer advice on fitting practices, lubrication regime, or modifications to the mounting arrangements to help improve future bearing life.

Bearings sent for analysis may be reconditioned, recycled or returned as appropriate.

Please inform Cooper if you wish to use this service, before returning bearings to one of our sites. A small charge may be made depending on requirements.

Recycling

The materials used in a Cooper bearing unit are almost completely recyclable. The diagram below helps to identify the various materials used in standard and popular optional versions of Cooper bearings so that they can be segregated as required.

OUTER HOUSING

Grey iron or ductile iron as standard.
Cast steel housings will usually have the letter 'S' inserted into their reference compared to the standard units listed in this catalogue (e.g. "PS07" instead of "P07" or "FS07" instead of "F07").
Fabricated housings are usually mild steel

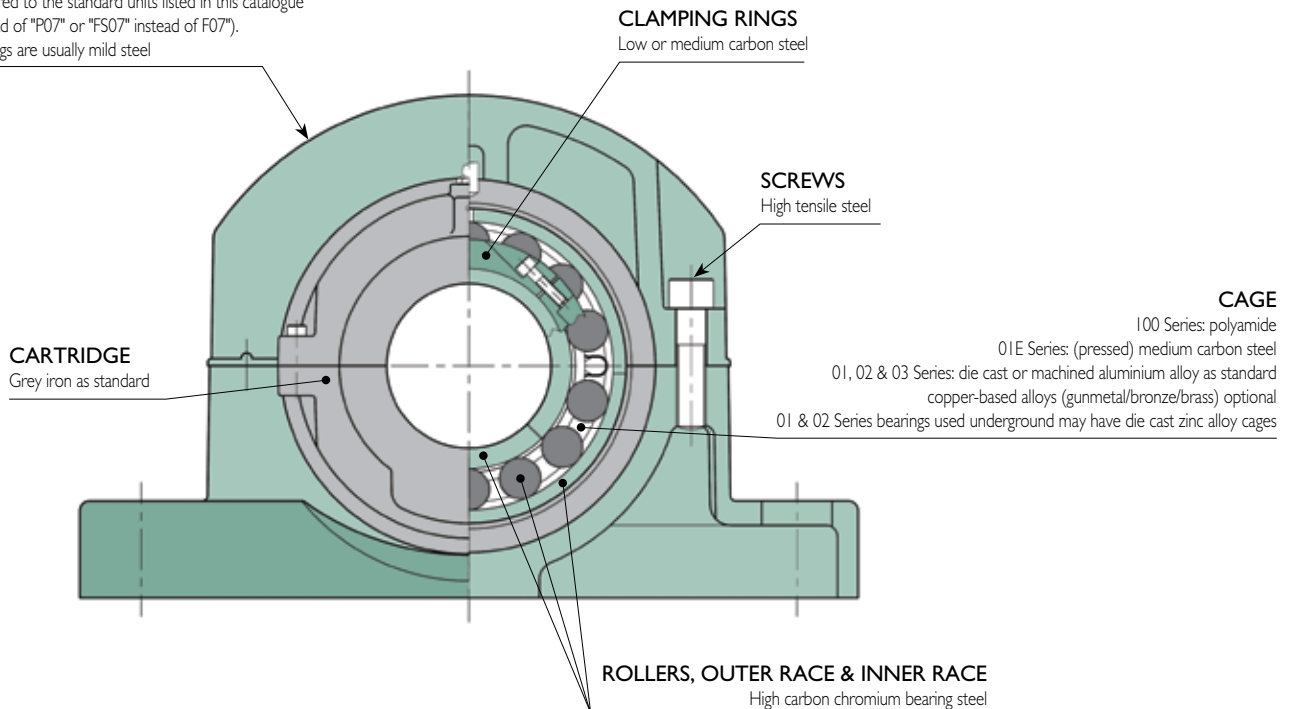

PROBLEM: OVERHEATING

Possible Cause	Solution
Shaft oversize. Bearing running tight	Provide shaft with correct tolerance. Contact Cooper technical department.
Aluminum triple labyrinth seal rubbing	Seal bore and labyrinth should be greased during installation.
Housing overpacked with grease or oil level too high	Bearing will purge excess grease through seals. Oil lubrication - reduce level to just below cage.
Wrong type of grease or oil causing lubricant breakdown.	Consult reliable lubricant manufacturer for proper type of lubricant or contact Cooper technical department.
Low oil level. Insufficient grease.	Oil level should be just below cage outside diameter. Add proper grease.
Inner race rubbing against seals.	Check clamping ring screws to make sure inner race is tight on the shaft. Make sure the expansion bearing is mounted properly with rollers positioned centrally on outer race.
Incorrect shaft alignment	Recheck alignment.
Bearing selected with inadequate internal clearance for high temperature operation.	Contact Cooper technical department.
Oil lubrication hole blocked. Grease passage blocked.	Inspect and clean holes. Refill to proper level.
Two fixed bearings on common shaft.	Remove one bearing and replace with an expansion bearing.
Pinching of bearing.	Make sure entire area of pedestal base is supported.
Bearing cartridge not aligned.	Lubricate cartridge spherical with anti-seize compound. With pedestal cap in place and cap bolts loose, rotate or run shaft a few revolutions while under load. Re-tighten cap bolts.

PROBLEM: NOISY BEARING

Possible Cause	Solution
Foreign matter or corrosive agent entering bearing.	Remove and inspect bearing and seals. Clean and re-lubricate bearing and seals.
Pinching of bearing.	Make sure entire area of pedestal base is supported.
Undersize shaft.	Measure shaft for proper fit. Refer to page 14.
Inner race rubbing against seals.	Check clamping ring screws to make sure the inner race is tight on shaft. Make sure the expansion bearing is mounted correctly with roller positioned centrally on the outer race.
Improper mounting of bearing.	Inspect bearing. Check that all match marks coincide. If parts are damaged, replace with new bearing.
Aluminum triple labyrinth seal rubbing	Seal bore and labyrinth should be greased during installation.
Low oil level. Insufficient grease.	Oil levels should be just below cage outside diameter. Add correct grease.

PROBLEM: NOISY BEARING (CONTINUED)

Possible Cause	Solution
Wrong type of grease or oil causing lubricant breakdown.	See lubrication section or contact Cooper technical department.
Bearing selected with incorrect internal clearance.	Contact Cooper technical department.
Shaft does not contain a fixed bearing.	Remove one expansion bearing and replace with fixed bearing.
Two fixed bearings on common shaft.	Remove one and replace with an expansion bearing.
Unbalanced load.	Re-balance machine.
Bearing exposed to vibration while machine is idle.	Examine bearing for brinelling separated by the distance equal to spacing of rollers. Replace bearing. Rotate shaft at least once every two weeks to prevent brinelling.

PROBLEM: VIBRATION

Possible Cause	Solution
Foreign matter or corrosive agent entering bearing.	Remove and inspect bearing and seals. Clean and re-lubricate bearing and seals.
Pinching of bearing.	Make sure the entire area of the pedestal base is supported.
Shaft undersize.	Measure shaft for proper fit. Refer to page 14.
Unbalanced load.	Re-balance machine.
Flat on roller due to skidding.	Replace bearing. Consult Cooper technical department if problem persists.
Improper mounting of bearing.	Inspect bearing. Check that all match marks coincide. If parts are damaged, replace with new bearing.
Bearing cartridge not aligned.	Lubricate cartridge spherical with anti-seize compound. With pedestal cap in place and cap bolts loose, rotate or run shaft a few revolutions while under load. Re-tighten cap bolts.
Excessive clearance in bearing resulting in vibration.	Use bearing with recommended internal clearance.
Failure to clean bearing before assembly.	Remove and carefully clean bearing and re-assemble with correct lubrication.

PROBLEM: BEARING LOOSE ON SHAFT

Possible Cause	Solution
Clamping rings not tightened sufficiently.	Make sure clamping rings are fully tightened. Refer to assembly procedure.
Undersize shaft.	Measure shaft for proper fit. Refer to page 14.
Shaft out of round or not parallel.	Measure shaft. Refer to page 14.

Who to Contact

With offices worldwide we have dedicated teams of specialists, sales managers and engineers with vast experience of industry requirements at your fingertips, wherever you are. Please see the back cover for the nearest office to you.

If you are situated in a country or areas where we don't yet have an office, then contact one of our many Cooper

authorised distribution partners, acting in your area on our behalf. For a complete list of distributors, please contact us or visit our website at www.CooperBearings.com.

There will always be someone available to answer your questions or point you in the right direction, so whatever your requirements don't hesitate to get in touch.

Compatibility of Bearings and Housings

There are 4 main sub-assemblies to a typical complete Cooper bearing unit:

BEARING

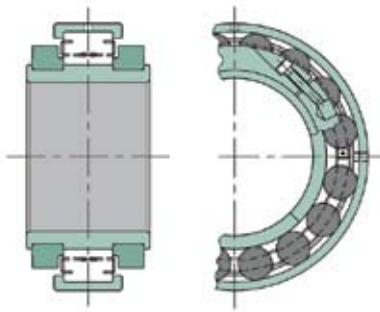

CARTRIDGE

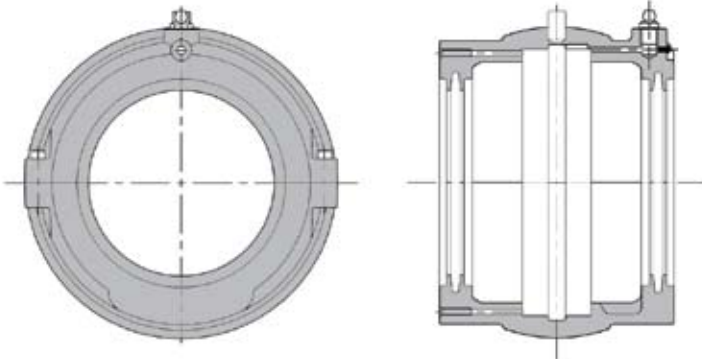

SEAL (ATL SHOWN)

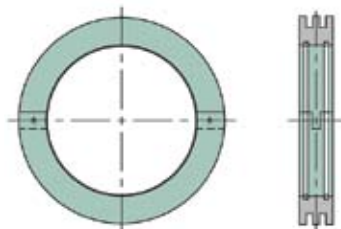

OUTER HOUSING

Pedestal

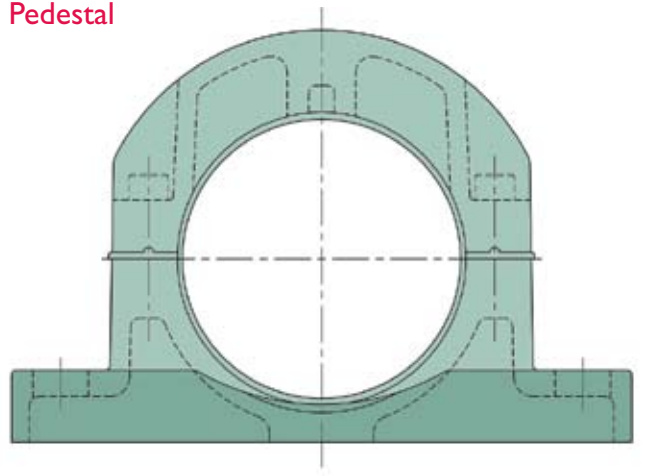

Flange

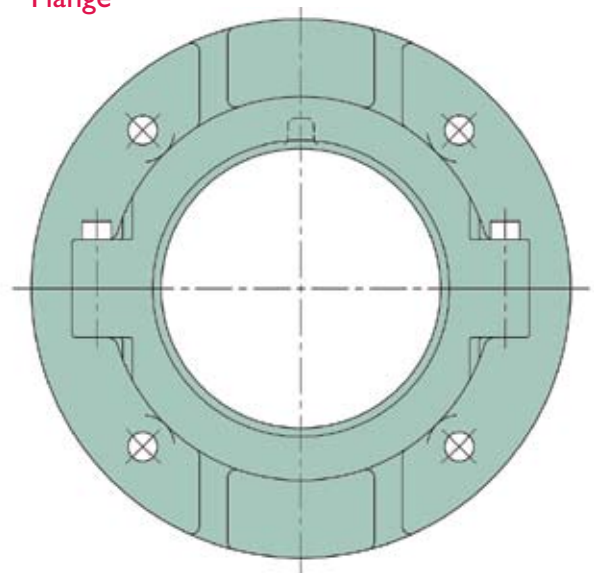

Generally these are interchangeable and may be ordered separately using the part codes listed in the relevant sections of this catalogue.

Individual components, such as a single race, are not generally supplied as they are not interchangeable between sub-assemblies.

Compatible bearing, cartridge and standard pedestal combinations are listed together in the relevant section. For other types of outer housing the reference of the compatible bearing is listed with the housing data, and the relevant cartridge part code (and further details of the bearing) can be found by reference to the bearings, cartridges and pedestals sections.

Cartridges and outer housings with matched diameters for reduced clearance are sometimes supplied, in which case the cartridge and outer housing cannot be replaced individually. Rod-end type housings have this feature as standard, and a matched cartridge is supplied with the outer housing.

Hanger units do not require a separate cartridge.

If standard cartridges with felt seals are specified, these seals are supplied with the cartridge. Other types of seal must be ordered separately. Felt seals are also available separately if required.

Bore Sizes

Part codes for bearings and cartridges with standard single seal grooves contain a reference to the bore size, e.g. (highlighted):

01 C **65M** EX
01 B **207** EX

Bore size references ending in 'M' indicate metric bores, with the preceding number the bore size in millimetres (e.g. '65M' indicates a 65mm bore, '200M' indicates a 200mm bore).

Bore sizes not ending in 'M' indicate inch-size bores. The last two digits indicate sixteenths of an inch, with the preceding digit(s) indicating whole inches. Some examples of inch-size bore references are as follows:

Reference	Bore size
207	2 ⁷ / ₁₆ "
415	4 ¹ / ₁₆ "
1008	10 ¹ / ₂ "
2000	20"

Some bearings and cartridges have a hyphenated bore size reference, e.g.:

01 B **600-160M** EX

In this case the part of the reference after the hyphen indicates the bore, using the format explained above. The part of the reference before the hyphen is used to distinguish the bearing from other bearings in the same series (in this case 01 Series) having the same bore size but different dimensions otherwise.

Note: Bore size reference marking on bearings

When determining the bore size of an existing bearing only the size reference on the inner race should be used to indicate actual bore size. Outer races, clamping rings and cage and roller assemblies are common to bearings of several bore sizes and may have a 'group' size reference that differs from the bore size of the inner race.

Bearing Types

The main configurations of bearing are explained on page 4.

Special Features

Suffix characters may be used to indicate special features.

Examples include:

Bearing features

C2/C3/C5	Special clearances as explained on page 10
AF	Axial float. This is preceded by the amount of axial float, e.g.: 2mm AF
AL(D)F	Aluminium cage with (double) flange (usually race riding)
AP	Air / grease purge points
CHAM	Special chamfer to inner race bore. This is followed by size of chamfer, e.g. (to indicate 7mm x 45° chamfer): CHAM 7
EXILOG	Bearing with fixed type outer race and floating inner race (see page 6)
FR	Full complement of rollers (no cage)
GM	Gunmetal / brass / bronze cage
GM(D)F	Gunmetal / brass / bronze cage with (double) flange (usually race riding)
GROSL	Single lipped outer race (see page 5)
OSO	Outer race set out (particularly for large bearings where outer race is usually retained in housing by radial screws)
XJR	Joint relief (to allow inner race to be mounted in recess)
ZN	Zinc alloy cage

174

Cartridge features

BOBP	Bolt-on blanking plate
BOBT	Bolt-on blanking plate with thrust bearing
BP/BT/ BPTL/BTTL	See page 22
IH	Inspection hole (for measuring position of inner race of expansion bearings once assembled)
OB	Overbore (cartridge end bore is larger than bearing bore) This is followed by end bore size, using same format as bearing bore reference, e.g.: OB 207 or OB 65M (or OB 65mm)
TE	Drilled for temperature indicator element
OIL LUB	Oil lubricated

References to special seal types (some of which require special cartridges) can be found on page 20.

A letter may succeed the 'C' in the cartridge designation to indicate that the cartridge is made from non-standard material. Taking the examples of 01 C 60M and 01 C 03 as examples:

01 CN 60M and 01 CN 03 would indicate nodular (ductile) iron.

01 CS 60M and 01 CS 03 would indicate steel.

01 CA 60M and 01 CA 03 would indicate aluminium.

Outer housing features

BEM	Base ends machined. This may be followed by machined length, e.g.: BEM 500mm
SI	Reduced swivel clearance between outer housing and cartridge
SLUB	Lubrication to spherical seat

For outer housings made in material other than standard, letters are interposed between the letter(s) designating the housing type (e.g. 'P' for pedestal, 'F' for flange or 'RET' for rod-end T-type) and the size designation. Taking the example of a P06 pedestal:

PN06 indicates a P06 in nodular (ductile) iron

PS06 indicates a P06 in steel

PA06 indicates a P06 in aluminium

Ductile iron and steel versions of an RET06 would be designated RETN06 and RETS06 respectively.

Numbers may be suffixed to bearing, cartridge or outer housing designations indicating a combination of special features or parts to special dimensions.

