

COOPER ROLLER BEARINGS: A PROVEN MATCH FOR CEMENT AND AGGREGATES INDUSTRY CHALLENGES

Few industries' profits rely more on the smooth functioning of bearings than cement & aggregates. From kilns which cannot be allowed to grind to an unscheduled halt to conveyors that must work constantly to keep them fed, no industry provides a stronger test of a bearing's ability to carry on working despite dust, grit, moisture and extreme temperatures.

Cooper originally conceived its split-to-the-shaft roller bearing for just the trapped and difficult-to-access locations that are so common in this industry, and continues to develop the technology in line with innovations in machinery and changes in practice in quarrying, transport and processing.

In line with the worldwide nature of the modern industry, Cooper today is present on six continents, with authorised supply chain partners in over thirty countries.

Easy-to-fit, easy to disassemble: the logic that underpins the cost benefits

Cooper roller bearings are completely split to the shaft, yet designed and engineered to be extremely fast and easy to assemble into robust, reliable units that give exceptional service under the harshest conditions.

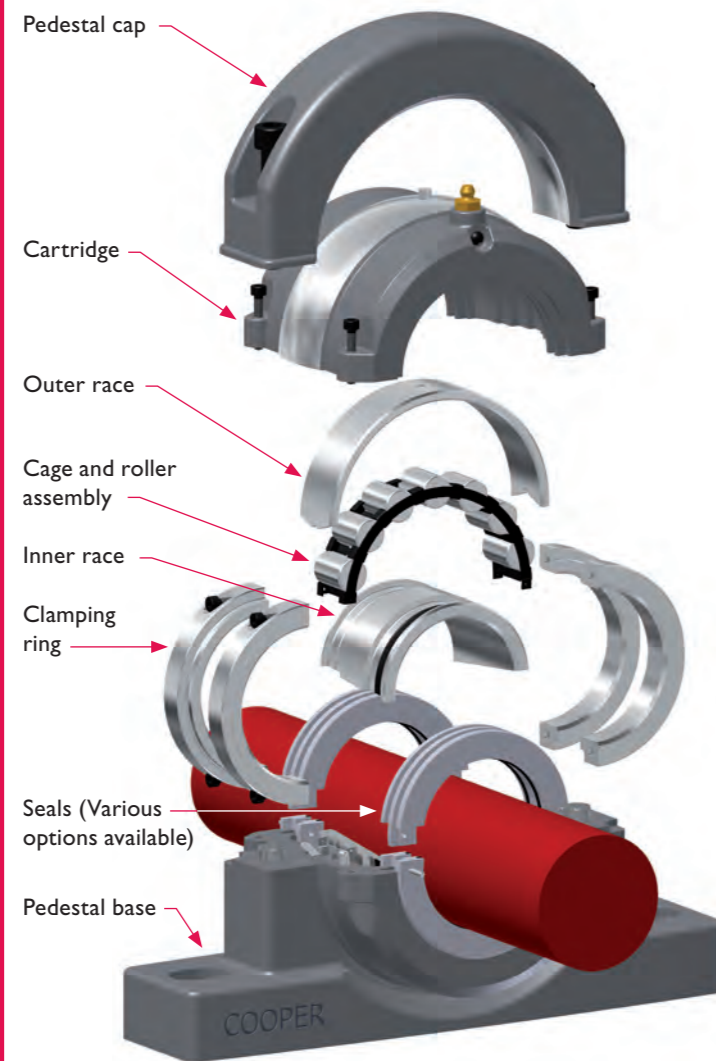

A wide range of mounting options

Available in a range of materials such as iron, nodular iron or steel, the variety of Cooper mountings reflects the wide spectrum of tasks which split roller bearings can perform. There is a full range of SN-, SAF- and SD-compatible pedestals.

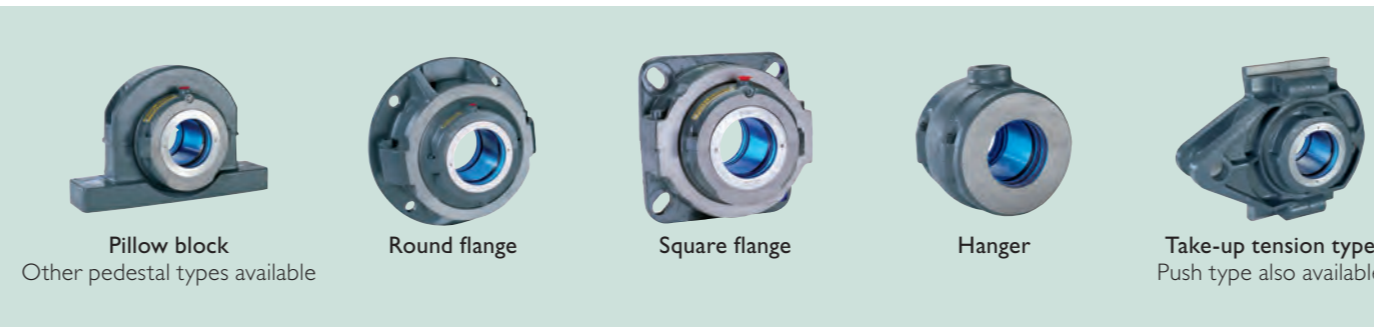

The perfect sealing solution for your application

Cooper offers a complete range of seals to ensure long bearing life by meeting the exact needs of a given location and working environment. Here are just a few of our seals typically used in the cement and aggregates industry.



What you can expect to save for each Cooper bearing installed

The diagram shows the areas in which Cooper bearings can save you money. A simple calculation will often show through-life savings of hundreds of thousands of pounds per bearing.

Please note that these considerations leave out the fast and easy inspection made possible by Cooper split roller bearings, which helps eliminate sudden failure and all its associated costs.

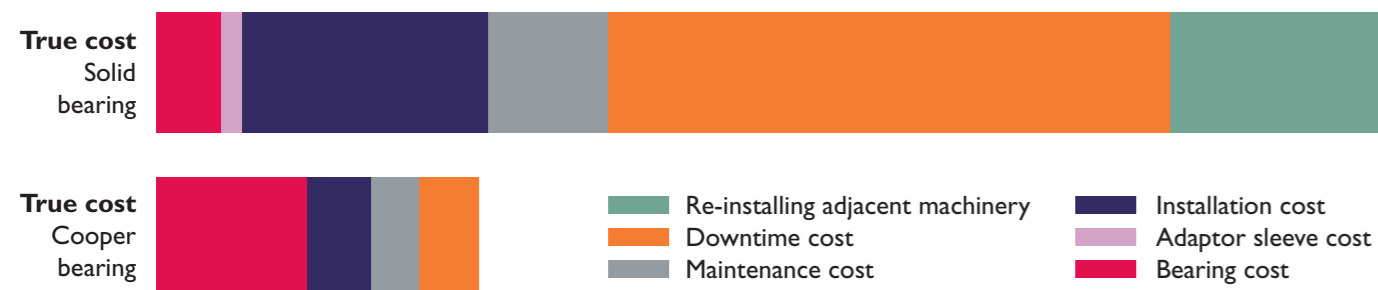

COOPER BEARINGS GROUP Customer Service Centres

UK, Europe, South America, Asia, Australia and the Middle East
Cooper Roller Bearings Company Ltd.
Wisbech Road
Kings Lynn, Norfolk, PE30 5JX
United Kingdom
Tel: +44 (0) 1553 763447
Fax: +44 (0) 1553 761113
Email: CoopersalesUK@kaydon.com

USA, Canada, Mexico and Central America
The Cooper Split Roller Bearing Corp.
5365 Robin Hood Road, Suite B
Norfolk, VA 23513
USA.
Tel: +1 (1) 757 460 0925
Fax: +1 (1) 757 464 3067
Email: CoopersalesUS@kaydon.com

Germany
Cooper Geteilte Rollenlager GmbH.
Postfach 100 423
Oberbenrader Str. 407
47704 Krefeld Germany
Tel: +49 (0) 2151 713 016
Fax: +49 (0) 2151 713 010
Email: CoopersalesDE@kaydon.com

People's Republic of China
Cooper Bearings Group Beijing.
Room 909, Canway Building Tower 1
No 66, Nanlishi Road, Xicheng District
Beijing
PRC 100045
Tel: +86 (0) 10 68080803
+86 (0) 10 68080805
+86 (0) 10 68080806
Fax: +86 (0) 10 68080801
Email: CoopersalesCN@kaydon.com

Brazil
Cooper do Brasil Ltda.
Caixa Postal 66.105
CEP 05.314-970, Brasil
Tel: +55 (0) 11 3022 3706
Tel: +55 (0) 11 9156 2500
Email: CoopersalesBR@kaydon.com

India
Cooper Roller Bearings Company Ltd.
Wisbech Road
Kings Lynn, Norfolk, PE30 5JX
United Kingdom
Tel: +91 (0) 9820180089
Email: CoopersalesIN@kaydon.com

Australia
Cooper Bearings Group
PO BOX 241, Kelmescott
Western Australia 6991
Tel: +61 (0) 8 93979990
Fax: +61 (0) 8 93979990
Email: CoopersalesAU@kaydon.com



www.cooperbearings.com

Document code: CPR018_aEng_Apr11



From quarry to bag, Cooper bearings underpin smooth, profitable operation

Cooper split roller bearings support the cement and aggregates industry across the many applications shown in the table below.

General	Quarrying & raw materials preparation	Clinker production	Milling/finishing	Storage and packing
Conveyors (incl. screw/belt/bar)	Crushers	Kiln drives	Clinker breakers	Cement pumps & pump drives
Elevators & cranes	Ball mill trunnions	Kiln under-rollers	Ball mill trunnions	
Motors and generators	Mill drives, including ball mill drives	Pre-heater grates	Ball mill drives	
Fans and blowers	Mill under-rollers		Tube mill drives	
Gearboxes	Separators		Mill under-rollers	
Crankshafts	Drum processor trunnions		Mixers and agitators	
Loading hoppers	Reciprocating screens & sizers (classifiers) Washers			

Conveyors

On screw, belt and bar conveyors Cooper split roller bearings, with their superior sealing and ease-of-use in trapped locations, keep some of the dustiest and most abrasive materials moving without a hitch.



Crushers and clinker breakers

Whether helping to transmit the force needed to crush limestone or aggregates, or to break clinker down to mill-ready particle sizes, Cooper bearings are designed to take both stress and dust in their stride.

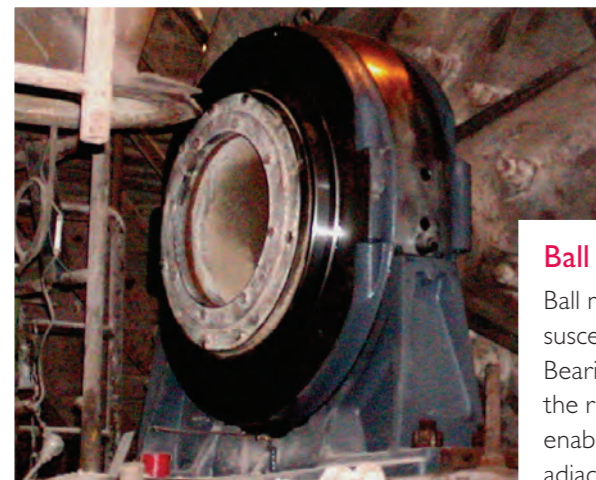

Kiln drives and under-rollers

Non-stop smooth working, often over many months, of the rotary kiln underpins the profitability of the entire cement works. Cooper bearings are a fitting choice to transmit the drive to, and support the motion of, the largest moving machines in use today.

Ball mill drives and trunnions, other mill drives

Ball mill trunnions require less power at start up and are less susceptible to shaft damage when fitted with Cooper Roller Bearings. In ball mill and other mill drives, Cooper Bearings reduce the risk of sudden failure by making inspection easier. They also enable any necessary work to be carried out without disturbing adjacent equipment or moving the shaft itself.

Fans & blowers

Fans and blowers play a key part in cooling, heating and separation of materials at all stages of manufacture, and are crucial to the movement of materials from one part of the process to the next. Under frequent, sudden acceleration or long periods of consistent running, Cooper bearings withstand some of the toughest, most abrasive conditions in any industry, without special cooling systems and using simple grease lubrication.

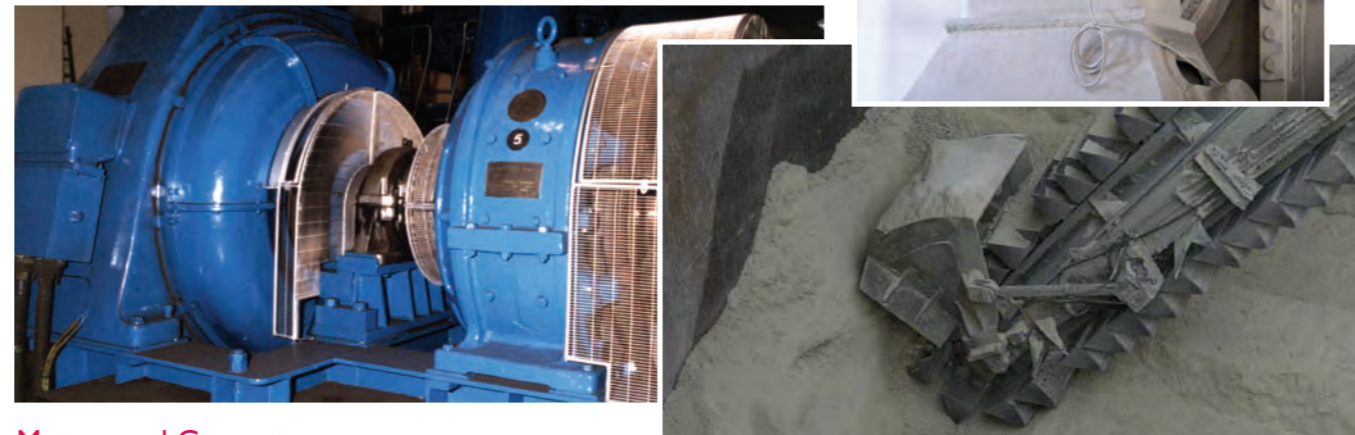
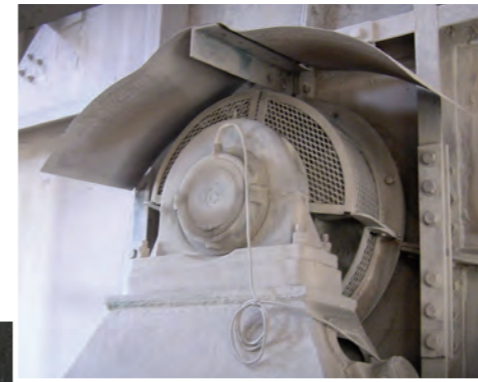

Motors and Generators

Cooper bearings have an important role in all kinds of motors and generators across the cement and aggregates industry. In trapped locations such as those shown here, they greatly reduce maintenance costs.

Elevators

Many elevators have bearings in trapped positions, making inspection difficult and repair costly in terms of labour and downtime. Swapping in Cooper split roller bearings can bring about enhanced lifetime performance by removing these two problems at a stroke.

Cooper bearings used in cement & aggregates

Cooper split roller bearings include the 100 Series of high-speed compact bearings, the medium duty 01 Series, heavy duty 02 Series and extra heavy duty 03 Series. In addition there is a rapidly developing range of double-row split tapered bearings. We also offer a heavy duty bearing in an SD-compatible heavy duty pedestal.

In addition, Cooper makes special bearings to its own and customer specifications (see page at right).

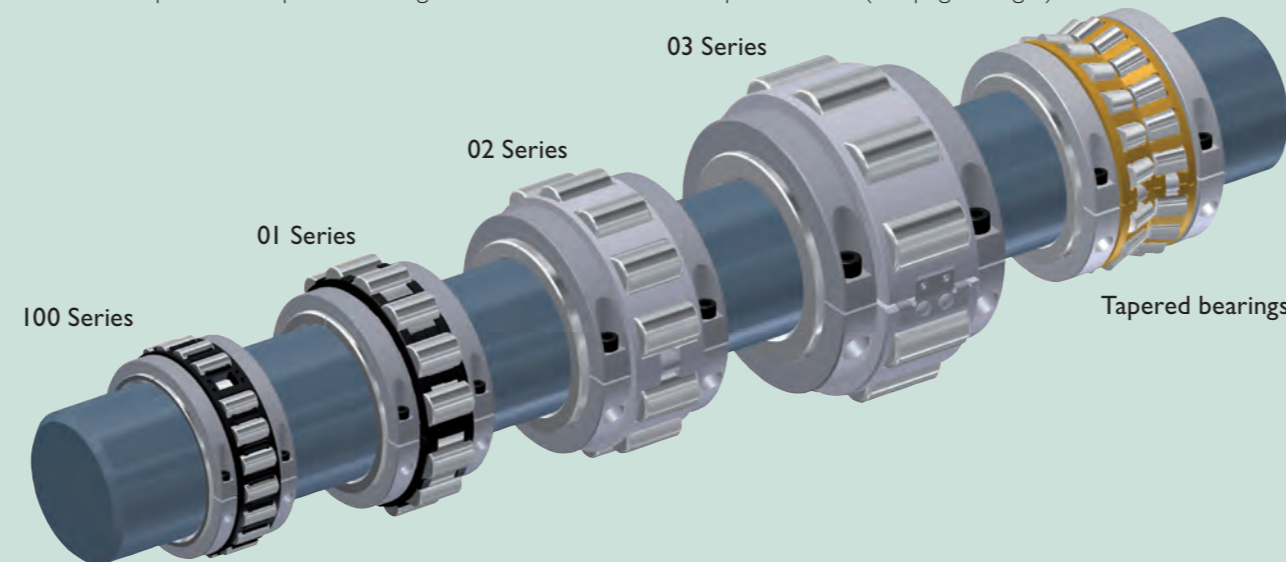

The basis of phenomenal through-life cost savings: Cooper roller bearings are split to the shaft

- Bearing installation is fast and easy no matter how 'trapped' the location
- No shaft realignment is required
- Inspection is simple and fast, aiding planned maintenance and reducing both downtime and "unexpected" failure
- Smaller range of operations needed, leading to task and toolbox simplification
- Handling weights are reduced (smaller, lighter pieces). Lifting gear is not required for most Cooper sizes. No lifting of nearby equipment is required

- A better long-term solution: the Cooper inner race protects the shaft and eliminates journal wear
- No cooling system is needed, thanks to low friction



The secret of long bearing life: a seal that stays aligned with the shaft, even when the shaft is misaligned

- Full seal integrity even if the shaft moves $\pm 2.5^\circ$
- Reduction of foreign material ingress, even in very dusty environments
- No running-in period needed
- Little lubricant leakage, making lubrication simpler and keeping work surfaces cleaner

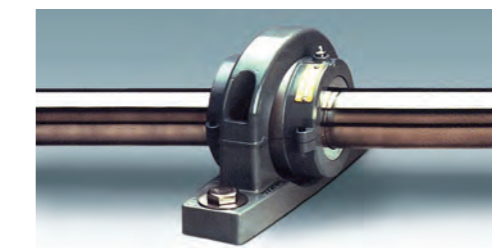

Cooper bearing

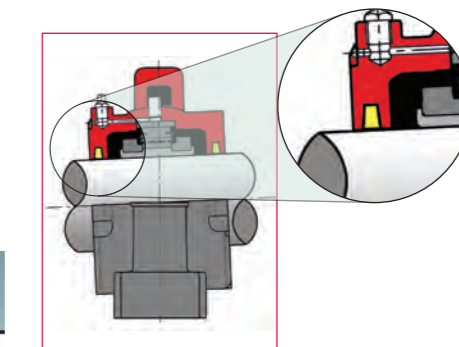

Thanks to its unique swivelling cartridge, the Cooper bearing allows the seal to remain concentric with the shaft at all times.

Double row spherical solid bearing

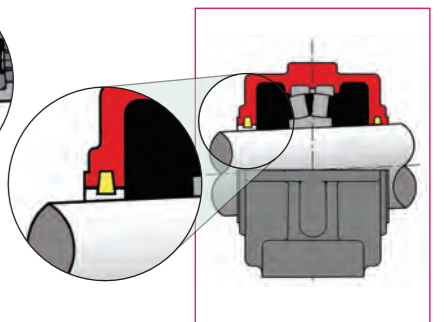

By contrast, the solid bearing arrangement opens up the seal or crushes it.

Made to order bearings for the cement and aggregates industry

In addition to a large range held in stock, Cooper designs and makes bearings to order. We frequently manufacture split or solid thrust and radial roller bearings up to 1.5m shaft diameter and have the skills and equipment to produce many other special products as well as to modify existing bearings and casings of our own or other manufacture.

Shown here are an 01 series 850mm EXILOG bearing for the trunnions of a ball mill and a 110mm solid eccentric bearing for a vibrating screen.

If you would like to use our custom services, please get in touch with your nearest Cooper Customer Service Centre (please see list on back page of this brochure).



850mm EXILOG bearing

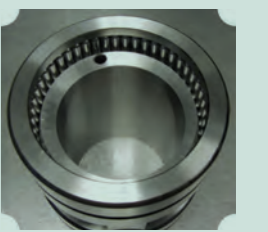

110mm solid eccentric bearing